

**GapVax<sup>®</sup>**



**PARTSEXPRESS**

A DIVISION OF GAPVAX, INC.

THE INDUSTRY'S PREMIERE PARTS AND ACCESSORIES SERVICE

**PARTS AND ACCESSORIES**

2 0 1 6   A d d i t i o n s   t o   o u r   C a t a l o g



**PARTSEXPRESS**

WHAT'S  
NEW

Texas Location  
281-884-8658

**GapVax**  
[www.gapvax.com](http://www.gapvax.com)

Headquarters  
Johnstown, PA  
888-442-7829

# DEBRIS AND GRIT CATCHERS

## DEBRIS CATCHERS FOR USE WITH FIBERGLASS POLES



**\*\*Made out of heavy duty spring wire for extended durability**



DC-06	6" DEBRIS CATCHER FOR USE WITH FIBERGLASS POLE SET
-------	--

DC-08	8" DEBRIS CATCHER FOR USE WITH FIBERGLASS POLE SET
-------	--

DC-10	10" DEBRIS CATCHER FOR USE WITH FIBERGLASS POLE SET
-------	---

DC-12	12" DEBRIS CATCHER FOR USE WITH FIBERGLASS POLE SET
-------	---

DC-15	15" DEBRIS CATCHER FOR USE WITH FIBERGLASS POLE SET
-------	---

DC-18	18" DEBRIS CATCHER FOR USE WITH FIBERGLASS POLE SET
-------	---

DC-24	24" DEBRIS CATCHER FOR USE WITH FIBERGLASS POLE SET
-------	---

FOR ROUND HOLE CYLINDER ADD \$20 AND ADD "R" AFTER PART NUMBER

## GRIT CATCHERS FOR USE WITH FIBERGLASS POLES



DCC-06	6" GRIT CATCHER FOR USE WITH FIBERGLASS POLE SET
--------	--

DCC-08	8" GRIT CATCHER FOR USE WITH FIBERGLASS POLE SET
--------	--

DCC-10	10" GRIT CATCHER FOR USE WITH FIBERGLASS POLE SET
--------	---

DCC-12	12" GRIT CATCHER FOR USE WITH FIBERGLASS POLE SET
--------	---

DCC-15	15" GRIT CATCHER FOR USE WITH FIBERGLASS POLE SET
--------	---

DCC-18	18" GRIT CATCHER FOR USE WITH FIBERGLASS POLE SET
--------	---

DCC-24	24" GRIT CATCHER FOR USE WITH FIBERGLASS POLE SET
--------	---

**\*\* Made out of 1/16" expanded metal and 1/16" solid steel \*\***

## (3 IN 1) GRIT / DEBRIS CATCHER W/ SCOOP

**\*\*Made out of 1/16" expanded metal and 1/16" solid steel**



DCC-6S	6" 3 IN 1 DEBRIS GRIT SCOOPER FOR USE WITH FIBERGLASS POLE SET
--------	--

DCC-8S	8" 3 IN 1 DEBRIS GRIT SCOOPER FOR USE WITH FIBERGLASS POLE SET
--------	--

DCC-10S	10" 3 IN 1 DEBRIS GRIT SCOOPER FOR USE WITH FIBERGLASS POLE SET
---------	---

DCC-12S	12" 3 IN 1 DEBRIS GRIT SCOOPER FOR USE WITH FIBERGLASS POLE SET
---------	---

**ALLOWS YOU TO REMOVE DEBRIS, GRIT AND SCOOP MATERIAL FROM MANHOLE INVERTS**

## FIBERGLASS POLE SETS



### GREEN FOAM FILLED FIBERGLASS POLE SETS

JE-4	4' GREEN FOAM FILLED FIBERGLASS POLE
JE-6	6' GREEN FOAM FILLED FIBERGLASS POLE
JE-8	8" GREEN FOAM FILLED FIBERGLASS POLE
JE-6/4	24' GREEN FOAM FILLED FIBERGLASS POLE SET INCLUDES (4) 6' FIBERGLASS POLES



### STEEL THREADED COUPLINGS



PD-FTC-1	FIBERGLASS POLE THREADED COUPLING SET
PD-FTC-2	FIBERGLASS POLE THREADED COUPLING SINGLE
PD-ACTA	ADAPTER CLIP / THREAD ASSEMBLY



### STEEL REINFORCED FIBERGLASS QUICK COUPLING POLE SETS

PD-FP6	6' STEEL YELLOW REINFORCED FIBERGLASS POLE
PD-FP12	12' STEEL YELLOW REINFORCED FIBERGLASS POLE
PD-FP24	24' STEEL REINFORCED FIBERGLASS POLE SET



### STEEL REINFORCED FIBERGLASS THREADED COUPLING POLE SETS

PD-FPT6	6' STEEL REINFORCED FIBERGLASS POLE W/ MXF THREADED COUPLING
PD-FPT12	12' STEEL REINFORCED FIBERGLASS POLE W/ MXF THREADED COUPLING
PD-FPT24	24' STEEL REINFORCED FIBERGLASS POLE W/ MXF THREADED COUPLING

# GRABBERS

## MCLAW

<b>MCLAW</b>	7' TO 15' TELESCOPIC EXTENDABLE FIBERGLASS POLE WITH 3 PRONG SPRING LOADED HEAVY DUTY CLAW END.
--------------	---



## EXTENDABLE DEBRIS GRABBER 5' - 15'

<b>PD-EDG-1</b>	5' - 15' EXTENDABLE DEBRIS GRABBER.
-----------------	-------------------------------------



## HANDI-CLAMS

<b>PD-HC-6</b>	6' HANDI CLAM
<b>PD-HC-8</b>	8' HANDI CLAM
<b>PD-HC-10</b>	10' HANDI CLAM
<b>PD-HC-12</b>	12' HANDI CLAM
<b>PD-HC-14</b>	14' HANDI CLAM
<b>PD-HC-16</b>	16' HANDI CLAM
<b>PD-HC-18</b>	18' HANDI CLAM
<b>PD-HC-20</b>	20' HANDI CLAM
<b>PD-HC-25</b>	25' HANDI CLAM



**\*\* SPECIFY 12" OR 16" BUCKET WHEN ORDERING \*\***

# MANHOLE TOOLS



## HOSE GRABBER

PD-LACHGT	HOSE GRABBER
-----------	--------------

Ideal tool for retrieving your sewer hose from deep manholes and also to insert nozzle into drop manholes. Its opposing rounded "C" hooks secure hose making grabbing it easy.



## HORSE SHOE GRABBER

PD-HG-2	HORSE SHOE GRABBER
---------	--------------------

A great tool for lowering nozzles into the line.



## 90 DEGREE RAKE / FORK

PD-FG3P	3 PRONG 90 DEGREE RAKE / FORK
---------	-------------------------------

PD-FG4P	4 PRONG 90 DEGREE RAKE / FORK
---------	-------------------------------

This rake/fork with 90° bend is ideal for grabbing roots and debris from manholes and storm drains.



## 3- PRONGED GRABBER

PD-M3PDG-1	3 PRONG GRABBER
------------	-----------------

Use to pull roots, rocks, and other hard to grab debris with ease.



Made of  
1/8" solid  
hot rolled steel

## DEBRIS SCOOPER

PD-DS6	6" DEBRIS SCOOPER
--------	-------------------

PD-DS8	8" DEBRIS SCOOPER
--------	-------------------

PD-DS10	10" DEBRIS SCOOPER
---------	--------------------

Used to capture debris in sewer lines.



## GREASE /DEBRIS CHOPPER

GCPH-1	GREASE / DEBRIS CHOPPER
--------	-------------------------

Use this tool to chop large blocks of grease and debris that float back while jetting

# MANHOLE TOOLS



## CATCH BASIN SPOON

CBS-1	CATCH BASIN SPOON
-------	-------------------

This tool is used to scoop out debris with ease from manholes or storm drains.



## CAMERA HOOK

CH-1	CAMERA HOOK
------	-------------

This tool can be used to lower your camera into the manholes or to retrieve your sewer hose.



## GRAPPLING HOOK

PD-GH	GRAPPLING HOOK FOR FIBERGLASS POLE
-------	------------------------------------

The grappling hook is an excellent tool for retrieving large debris from manholes.



## SAND TRAP ELBOWS

Call for pricing 814-535-6766

PD-ST6	SAND TRAP ELBOW FOR 6" PIPE
PD-ST8	SAND TRAP ELBOW FOR 8" PIPE
PD-ST10	SAND TRAP ELBOW FOR 10" PIPE
PD-ST15	SAND TRAP ELBOW FOR 15" PIPE

Insert a sand trap on the stream side of the manhole and the user will be able to remove the debris rather than have the debris flow into the next section of sewer pipe.



## MANHOLE ROLLERS

PD-DO-6D	TOP MANHOLE ROLLER
PD-LMR	LOWER MANHOLE ROLLER



**Top Manhole Roller:** Allows the user to operate the jetting machine from a machine from a remote location when set up directly over the manhole is not possible. May be used with any size hose.

**Lower Manhole Roller:** The heavy duty lower manhole roller has a looped end which slides into the pipe invert to keep the roller in the proper position. The flared guide end with roller allows the hose to pass and protects it from scrapes and cuts. Also includes a hose grabber to help.

# NOZZLE EXTENSIONS



## FOOTBALL STYLE NOZZLE EXTENSIONS

1"	3/4"	
PD-NEFB-16	PD-NEFB-346	6" FOOTBALL STYLE NOZZLE EXTENSION
PD-NEFB-18	PD-NEFB-348	8" FOOTBALL STYLE NOZZLE EXTENSION
PD-NEFB-110	PD-NEFB-3410	10" FOOTBALL STYLE NOZZLE EXTENSION
PD-NEFB-112	PD-NEFB-3412	12" FOOTBALL STYLE NOZZLE EXTENSION

Manufactured of Sch. 80 black pipe, threads are single point (forged threads), springs made out of OTMB Class 2 spring steel wire.



## FINNED STYLE NOZZLE EXTENSIONS

1"	3/4"	
PD-NEF-16	PD-NEF-346	6" FINNED STYLE NOZZLE EXTENSION
PD-NEF-18	PD-NEF-348	8" FINNED STYLE NOZZLE EXTENSION
PD-NEF-110	PD-NEF-3410	10" FINNED STYLE NOZZLE EXTENSION
PD-NEF-112	PD-NEF-3412	12" FINNED STYLE NOZZLE EXTENSION



## SIX WIRE SKIDS

1"	3/4"	
PD-NEBS-16	PD-NEBS-346	6" SIX WIRE NOZZLE EXTENSION
PD-NEBS-18	PD-NEBS-348	8" SIX WIRE NOZZLE EXTENSION
PD-NEBS-110	PD-NEBS-3410	10" SIX WIRE NOZZLE EXTENSION
PD-NEBS-112	PD-NEBS-3412	12" SIX WIRE NOZZLE EXTENSION

Manufactured of Sch. 80 black pipe, threads are single point (forged threads), springs made out of OTMB Class 2 spring steel wire.



# NOZZLE EXTENSIONS



PROOFERS		
1"	3/4"	
PD-PR-6-1	PD-PR-6-34	6" PROOFER
PD-PR-7.5-1	PD-PR-7.5-34	7.5" PROOFER
PD-PR-8-1	PD-PR-8-34	8" PROOFER
PD-PR-9.5-1	PD-PR-9.5-34	9.5" PROOFER
PD-PR-10-1	PD-PR-10-34	10" PROOFER
PD-PR-12-1	PD-PR-12-34	12" PROOFER



SIX WIRE NOZZLE EXTENSION (ULTRA SHORTY)		
1"	3/4"	
PD-US-16	PD-US-346	6" SIX WIRE ULTRA SHORTY EXTENSION
PD-US-18	PD-US-348	8" SIX WIRE ULTRA SHORTY EXTENSION
PD-US-110	PD-US-3410	10" SIX WIRE ULTRA SHORTY EXTENSION

Manufactured of Sc. 80 black pipe, threads are a single point (forged threads), springs made out of OTMB Class 2 spring steel wires.

# NOZZLES

## SANITARY, GRENADE, CHISEL AND CLEANING NOZZLE



PD-SCN-1	SANITARY CLEANING NOZZLE 1" (comes with 8 rear jets with optional front jet)
PD-SCN-34	SANITARY CLEANING NOZZLE 3/4" (comes with 8 rear jets with optional front jet)



PD-GCN-1	GRENADE CLEANING NOZZLE 1"
PD-GCN-34	GRENADE CLEANING NOZZLE 3/4"

\* AVAILABLE IN TIER 3 \*



PD-CN-1	CHISEL NOZZLE 1"
PD-CN-34	CHISEL NOZZLE 3/4"



PD-HE-1	High Efficiency Aluminum Nozzle 1"
PD-HE-34	High Efficiency Aluminum Nozzle 3/4"

\* TIER 3 ANODIZED \*



## TURBO HYDRO-EXCAVATING NOZZLE

NOZ007873	1/4" Inlet; 5,100 PSI Max, 12 GPM
-----------	-----------------------------------



## RIPSAW HYDRO-EXCAVATING NOZZLE

NOZ022403	1/2" Inlet; 3,200 PSI Max, 12 GPM
-----------	-----------------------------------



## HYDRO-EXCAVATING TRIGGER GUN

ACC022608	1/2" Inlet; 1/2" Outlet; Max. Pressure 4,500 PSI
TLS011253	3/8" Inlet; 1/4" Outlet; Max. Pressure 4,000 PSI



**SCAN TO  
VIEW  
FULL  
PARTS  
CATALOG**



*Texas Location*  
281-884-8658



[www.gapvax.com](http://www.gapvax.com)

*Headquarters*  
Johnstown, PA  
888-442-7829



**COBRA** sewer cleaning hose is engineered and manufactured to handle the toughest and most harsh conditions found in high-pressure sewer cleaning applications. Its thermoplastic composition and unique bonded construction allows for a flexible and light-weight hose, along with superior kink resistance, and improved fitting retention. The high tensile strength polyester reinforcement provides for exceptional low volumetric expansion and eliminates moisture absorption. **Cobra** also features a tough polyether-urethane cover that offers maximum resistance to cutting, abrasion, various chemicals, and fungus.

In accordance with **WASTEC** (formerly **WEMI**) specifications, **Cobra** sewer cleaning hose offers a cream colored inner tube and corresponding markings on all assembly components. **Cobra** hose cover colors conform to industry standards for maximum operating pressure ratings.

**SERIES 4625 SEWER CLEANING HOSE – 2500 PSIG WORKING PRESSURE**

 Series #    Cover Color		Nominal Size		Pressures		Min. Bend Radius	Weight Per 100'
		I.D.	O.D.	Max. W.P.	Min Burst		
		Inches	Inches	PSIG	PSIG	Inches	(Lbs.)
4625-12	Orange	3/4	1.140	2500	6250	4.0	29.0
4625-16	Orange	1	1.430	2500	6250	6.0	38.0

**Tube:** Polyester core tube. Cream color.  
**Cover:** Orange abrasion resistant polyurethane.  
**Branding:** Black letter ink jet branding.

**Reinforcement:** Braided polyester fibers.  
**Temperatures:** -40°F. to +125°F. (-40°C. to +52°C.)

**SERIES 4630 SEWER CLEANING HOSE – 3000 PSIG WORKING PRESSURE**

 Series #    Cover Color		Nominal Size		Pressures		Min. Bend Radius	Weight Per 100'
		I.D.	O.D.	Max. W.P.	Min Burst		
		Inches	Inches	PSIG	PSIG	Inches	(Lbs.)
4630-12	Blue	3/4	1.170	3000	7500	4.0	30.0
4630-16	Blue	1	1.470	3000	7500	8.0	46.0

**Tube:** Polyester core tube. Cream color.  
**Cover:** Blue abrasion resistant polyurethane.  
**Branding:** Black letter ink jet branding.

**Reinforcement:** Braided polyester fibers.  
**Temperatures:** -40°F. to +125°F. (-40°C. to +52°C.)

**SERIES 4640 SEWER CLEANING HOSE – 4000 PSIG WORKING PRESSURE**

 Series #    Cover Color		Nominal Size		Pressures		Min. Bend Radius	Weight Per 100'
		I.D.	O.D.	Max. W.P.	Min Burst		
		Inches	Inches	PSIG	PSIG	Inches	(Lbs.)
4640-08	Lime Green	1/2	.89	4000	10,000	4.0	19.5

**Tube:** Polyester core tube. Cream color.  
**Cover:** Green abrasion resistant polyurethane.  
**Branding:** Black letter ink jet branding.

**Reinforcement:** Braided polyester fibers.  
**Temperatures:** -40°F. to +125°F. (-40°C. to +52°C.)

**For safety assurance, Cobra sewer cleaning hose is factory tested and sold as assemblies only.**

# FITTINGS & TOOLING FOR FIELD COUPLING OF COBRA SEWER CLEANING HOSE

POLYFLOW offers the *Cobra* Swage Tools for the field attachment of end fittings and menders. To assure proper matching of all components, the hose tube, material, end fittings, menders, and tooling must be color coded white. It is important to note that fittings and menders for thermoplastic hose are not necessarily interchangeable. By following the *Cobra* hose inspection instruction card (included with each reel of hose), and swage assembly instructions, the user can be assured of making an acceptable hose assembly.

## COUPLINGS

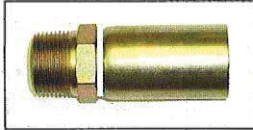

Part #	Male Thread	Hose Size
8MP-8R8	1/2" NPTF	1/2"
12MP-12R8	3/4" NPTF	3/4"
16MP-16R8	1" NPTF	1"

## MENDERS

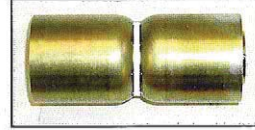

Part #	Hose Size
SCM-40-08	1/2"
SCM-12	3/4"
SCM-16	1"

## PUSHERS & DIES

Hose Size	Dies	Pushers	
		PF681 Swager	HH01 Swager
1/2" I.D.	4540-H0800	10P	4599-MP009
3/4" I.D.	4540-H1200	12P	4599-MP011
1" I.D.	4540-H1600	16P	4599-MP013

Note: Two sets of dies and pushers are required for PF681 swager to utilize the machine for menders attachment.

## Part Numbers For Hose Reel Assemblies-MP x MP Pipe

Hose Type & Size	Working Pressure	Length of Reel
4625-12-400	2500 PSI	400'
4625-12-500	2500 PSI	500'
4625-12-600	2500 PSI	600'
4625-16-400	2500 PSI	400'
4625-16-500	2500 PSI	500'
4625-16-600	2500 PSI	600'
4630-12-400	3000 PSI	400'
4630-12-500	3000 PSI	500'
4630-12-600	3000 PSI	600'
4630-16-400	3000 PSI	400'
4630-16-500	3000 PSI	500'
4630-16-600	3000 PSI	600'
4640-08-400	4000 PSI	400'
4640-08-500	4000 PSI	500'
4640-08-600	4000 PSI	600'

## COBRA SWAGE TOOLS

The *Cobra* swage tools are both portable and simple to use. These machines are designed to attach both end fittings and menders.

Specify hose sizes:  
-8, -12, or -16.

PF681 Swager

HH01 Swager

**Cobra Swage Machine**  
P/N *Cobra* PF681  
(Couplings & menders)  
Add (2) pushers, (2) dies for  
Attaching menders and couplings

**Cobra Hand Operated  
Swage Machine**  
P/N *Cobra* HH01  
(Couplings only)

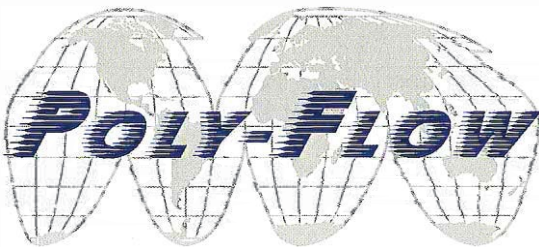
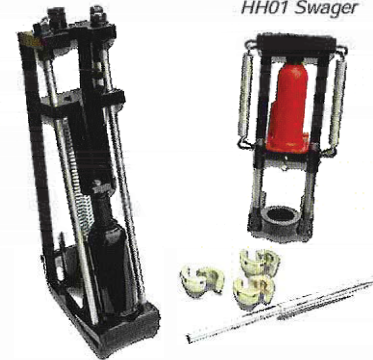

2668 NE Riverside Way • Portland, OR 97211  
(503) 493-0015 • Fax: (503) 493-0106

Distributed By:

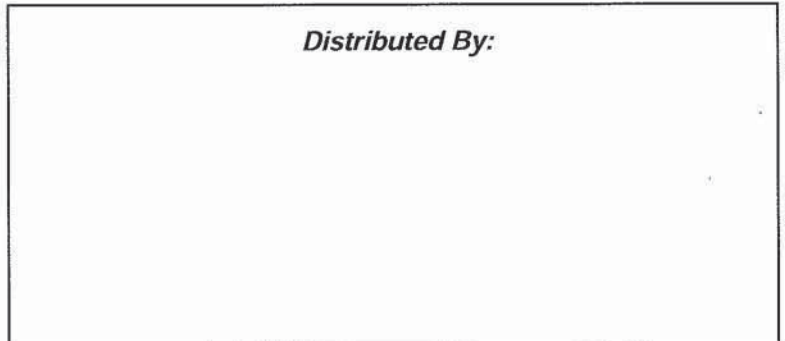

# **BLUE STAR**

*Nozzles made in Germany.*





 **Pfeil Düse 1/2“**

Hergestellt aus verschleißfestem, gehärtetem Stahl, durchbohrt die Quattro Düse mit ihren vier Vorstrahldüsen und scharfen Kanten jede Verstopfung und Vereisung in kurzer Zeit.

**Technische Beschreibung:**

- ✓ Auswechselbare VA Düseneinsätze mit Gewinde im Vorstrahl
- ✓ Wasserabstahlwinkel hinten 23°
- ✓ Wasserabstrahlwinkel vorne 0° und 15°
- ✓ 3/4“ Schlauchanschluss mit Adapter möglich (erhältlich in Zubehör)
- ✓ Bohrspitze ausrüstbar (erhältlich in Zubehör)

 **Arrow Nozzle 1/2“**

Precision engineered and manufactured of wear-resistant tempered steel, the Arrow Nozzles provide excellent performance in the most difficult cleaning application, by totally cutting and breaking through total obstructions in no time with its four very strong, concentrated forward jets and sharp cutting edges.

**Technical Specifications:**

- ✓ Replaceable, threaded stainless steel nozzle inserts
- ✓ Rear water jet angle 23°
- ✓ Forward water jet angle 0°
- ✓ Front water jet angle 15°
- ✓ Drill Point available in Accessories
- ✓ Capable of being used with recycled water

Length	Ø	Inserts	Jets	Min. flowrate	Pipe Ø	Weight
Länge		Einsätze	Winkel	Min. Durchfluss	Arbeitsbereich	Gewicht
2,20“	1,16“	R: 6x drilled / FJ 3x M5 ISK / 0° M6 ISK	0°/15°/23°	11 US gallon	3“ - 8“	0,3 lbs



**Pfeil Düse 1/2“ DP**

Wie die Pfeil Düse 1/2“ jedoch mit Bohrspitze im 0° Vorstrahl.

**Technische Beschreibung:**

- ✓ Auswechselbare VA Düseneinsätze mit Gewinde im Vorstrahl
- ✓ Wasserabstahlwinkel hinten 23°
- ✓ Wasserabstrahlwinkel vorne 0° und 15°
- ✓ 3/4“ Schlauchanschluss mit Adapter möglich (erhältlich in Zubehör)
- ✓ Mit Bohrspitze ausgerüstet

**Arrow Nozzle 1/2“ DP**

Precision engineered and manufactured of wear-resistant tempered steel, the Arrow Nozzles provide excellent performance in the most difficult cleaning application, by totally cutting and breaking through total obstructions in no time with its four very strong, concentrated forward jets and sharp cutting edges. Comes equipped with a Drill Point.

**Technical Specifications:**

- ✓ Replaceable, threaded stainless steel nozzle inserts
- ✓ Rear water jet angle 23°
- ✓ Forward water jet angle 0°
- ✓ Front water jet angle 15°
- ✓ Drill Point equipped
- ✓ Capable of being used with recycled water

Length	Ø	Inserts	Jets	Min. flowrate	Pipe Ø	Weight
Länge		Einsätze	Winkel	Min. Durchfluss	Arbeitsbereich	Gewicht
3“	1,16“	R: 6x drilled / FJ 3x M5 ISK / 0° M6 ISK	0°/15°/23°	11 US gallon	3“ - 8“	0,3 lbs





## General Düse 1/2"

Hergestellt aus verschleißfestem, gehärtetem Stahl, werden die General Düsen mit Vorstrahl und Blinndüseneinsatz (austauschbar) geliefert. Sie ist hervorragend geeignet zum Einsatz bei präventativer Wartung und zur Rundumreinigung der Kanalisation.

Zwei unterschiedliche Wasserabstrahlwinkel - 15° and 25° - bei jeweils vier VA Düseneinsätzen schaffen eine ideale Abstimmung zwischen Zug- und Reinigungsleistung, wobei die enorme Reinigungsleistung durch eine innovative, technisch optimierte Wasserführung erreicht wird.

### Technische Beschreibung:

- ✓ Einteilige Düse mit optimierter Wasserführung
- ✓ Auswechselbare VA Düseneinsätze mit Gewinde
- ✓ Wasserabstrahlwinkel 15° und 25°
- ✓ 3/4" Schlauchanschluss mit Adapter möglich (erhältlich in Zubehör)
- ✓ Einsetzbar bei Wasserrückgewinnern (Mit Keramik Düseneinsätzen)



## General Nozzle 1/2"

Precision engineered and manufactured of wear-resistant tempered steel with one forward jet and blind plug (interchangeable) included, the General is a perfect nozzle for preventative maintenance and all-around sewer cleaning.

Two different water jet angles - 15 and 25 degrees (four jets each) provide strong traction and highly efficient cleaning.

### Technical Specifications:

- ✓ Optimized Hydro Mechanics
- ✓ Replaceable, threaded stainless steel nozzle inserts
- ✓ Rear water jet angles 15° and 25°
- ✓ 3/4" hose connection possible (bushing from accessories)
- ✓ Capable of being used with recycled water

Length	Ø	Inserts	Jets	Min. flowrate	Pipe Ø	Weight
Länge		Einsätze	Winkel	Min. Durchfluss	Arbeitsbereich	Gewicht
2,80"	1,80"	R: 6x M6 ISK / FJ M6 ISK	15°/25°	16 US gallon	4" - 10"	1.6 lbs





## Fly Düse 1/2"

Präzise entwickelt und hergestellt aus verschleißfestem und gehärtetem Stahl, ist die Fly Düse ein hervorragendes hydrodynamisches Werkzeug für sehr hohe Anwendungsansprüche. Der enge, einzelne Wasserabstrahlwinkel von 7° in Verbindung mit einer innovativen, technisch optimierten Wasserführung sorgt für eine hervorragende Zug- und Reinigungsleistung, die insbesondere in langen Rohrleitungen und hügeligen Gelände zu ihrer Geltung kommt.

### Technische Beschreibung:

- ✓ Einteilige Düse mit optimierter Wasserführung
- ✓ Auswechselbare VA Düseneinsätze mit Gewinde
- ✓ Wasserabstrahlwinkel 7°
- ✓ 3/4" Schlauchanschluss mit Adapter möglich (erhältlich in Zubehör)
- ✓ Einsetzbar bei Wasserrückgewinnern (Mit Keramik Düseneinsätzen)

## Power Pull Nozzle 1/2"

Precision engineered and manufactured of wear-resistant tempered steel, the Power Pull Nozzle is an ideal tool for some of the toughest applications. The narrow, single 7 degree jet angle provides tremendous traction and cleaning performance in mountainous, difficult terrain. Great nozzle to clean and remove sand, silt and large debris from sewer lines.

### Technical Specifications:

- ✓ Optimized Hydro Mechanics
- ✓ Replaceable, threaded stainless steel nozzle inserts
- ✓ Rear water jet angle 7°
- ✓ Capable of being used with recycled water

Length	Ø	Inserts	Jets	Min. flowrate	Pipe Ø	Weight
Länge		Einsätze	Winkel	Min. Durchfluss	Arbeitsbereich	Gewicht
2,20"	1,80"	6x M6 ISK	7°	16 US gallon	4" - 10"	1,6 lbs



## Standard Düse 1/2"

Präzise entwickelt und hergestellt aus verschleißfestem, gehärtetem Stahl, alle Standard Reinigungsdüsen werden mit Vorstrahl und zusätzlichem Blinndüseneinsatz (austauschbar) geliefert. Der Abstrahlwinkel beträgt 23°. Die Standard Reinigungsdüse ist ideal zur Beseitigung von Sand, Schlack und weichen Ablagerungen.

### Technische Beschreibung:

- ✓ Optionaler Vorstrahl oder Blinndüseneinsatz bei Kamerabefahrung des Kanals
- ✓ Wasserabstrahlwinkel 23°



## Standard Nozzle 1/2"

Precision engineered and manufactured of wear-resistant tempered steel, each Standard Nozzle includes one forward jet and blind plug (interchangeable). Jet angle is 23 degree. The Standard Cleaning Nozzle is light, maneuverable and highly efficient.

### Technical Specifications:

- ✓ Optional front jet
- ✓ Rear water jet angle 23°

Length	Ø	Inserts	Jets	Min. flowrate	Pipe Ø	Weight
Länge		Einsätze	Winkel	Min. Durchfluss	Arbeitsbereich	Gewicht
2"	1,20"	R: 6x drilled / FJ M5 ISK	23°	11 US gallon	3" - 6"	0,3 lbs



## Flunder Düse 1/2"

Hergestellt aus verschleißfestem, gehärtetem Stahl sind die Flunder Düsen hervorragend geeignet für die Reinigung von Rohren mit starker Verschmutzung, verursacht durch Sand, Schlamm, Kies und Ablagerungen. Das Design der Flunder mit ihren abgerundeten Ecken und Vermeidung von Kanten verleiht ihr eine sehr gute Gleitfähigkeit in den Rohren.

### Technische Beschreibung:

- ✓ Auswechselbare VA Düseneinsätze mit Gewinde
- ✓ Wasserabstrahlwinkel 5°/20° bei 1/2" Schlauchanschluß
- ✓ Einsetzbar bei Wasserrückgewinnern (Mit Keramik Düseneinsätzen)

## Flounder Nozzle 1/2"

Precision engineered and manufactured of wear-resistant tempered steel, the Flounder nozzle is an excellent tool to clean the floor of pipes. The smooth design with rounded corners and edges provide the nozzle with a great gliding capability.

### Technical Specifications:

- ✓ Replaceable, threaded stainless steel nozzle inserts
- ✓ Water jet angles 5°/20°

Length x Width x Hight	Inserts	Jets	Min. flowrate	Pipe Ø	Weight
Länge x Breite x Höhe	Einsätze	Winkel	Min. Durchfluss	Arbeitsbereich	Gewicht
6" x 3,60" x 1,60"	4x M8 ASK	5°/20°	16 US gallon	6" - 12"	4,5 lbs



**Pfeil Düse 1" DP**

Wie die Pfeil Düse 1" jedoch mit Bohrspitze im 0° Vorstrahl.

Hergestellt aus verschleißfestem, gehärtetem Stahl, durchbohrt die Pfeil Düse mit ihren vier Vorstrahldüsen und scharfen Kanten jede Verstopfung und Vereisung in kurzer Zeit.

**Technische Beschreibung:**

- ✓ Auswechselbare VA Düseneinsätze mit Gewinde
- ✓ Wasserabstahlwinkel hinten 23°
- ✓ Wasserabstrahlwinkel vorne 0° und 15°
- ✓ 3/4" und 1 1/4" Schlauchanschluss mit Adapter möglich (erhältlich in Zubehör)
- ✓ Einsetzbar bei Wasserrückgewinnern (Mit Keramik Düseneinsätzen)
- ✓ Bohrspitze ausgerüstet

**Arrow Nozzle 1" DP**

Precision engineered and manufactured of wear-resistant tempered steel, the Arrow Nozzles provide excellent performance in the most difficult cleaning application, by totally cutting and breaking through total obstructions in no time with its four very strong, concentrated forward jets and sharp cutting edges. Comes equipped with a Drill Point

**Technical Specifications:**

- ✓ Replaceable, threaded stainless steel nozzle inserts
- ✓ Rear water jet angle 23°
- ✓ Forward water jet angle 0°
- ✓ Front water jet angle 15°
- ✓ 3/4" – 1 1/4" hose connection (with bushings available in Accessories)
- ✓ Drill Point equipped
- ✓ Capable of being used with recycled water

Length	Ø	Inserts	Jets	Min. flowrate	Pipe Ø	Weight
Länge		Einsätze	Winkel	Min. Durchfluss	Arbeitsbereich	Gewicht
5,60"	2,50"	R: 8x M8 ASK / FJ 3x M8 ASK / 0° M10x1 ASK	0°/15°/23°	50 US gallon	6" - 16"	2,2 lbs



## Pfeil Düse 1“

Hergestellt aus verschleißfestem, gehärtetem Stahl, durchbohrt die Pfeil Düse mit ihren vier Vorstrahldüsen und scharfen Kanten jede Verstopfung und Vereisung in kurzer Zeit.

### Technische Beschreibung:

- ✓ Auswechselbare VA Düseneinsätze mit Gewinde
- ✓ Wasserabstahlwinkel hinten 23°
- ✓ Wasserabstrahlwinkel vorne 0° und 15°
- ✓ 3/4“ und 1 1/4“ Schlauchanschluss mit Adapter möglich (erhältlich in Zubehör)
- ✓ Einsetzbar bei Wasserrückgewinnern (Mit Keramik Düseneinsätzen)
- ✓ Bohrspitze ausrüstbar (erhältlich in Zubehör)

## Arrow Nozzle 1“

Precision engineered and manufactured of wear-resistant tempered steel, the Arrow Nozzles provide excellent performance in the most difficult cleaning application, by totally cutting and breaking through total obstructions in no time with its four very strong, concentrated forward jets and sharp cutting edges.

### Technical Specifications:

- ✓ Replaceable, threaded stainless steel nozzle inserts
- ✓ Rear water jet angle 23°
- ✓ Forward water jet angle 0°
- ✓ Front water jet angle 15°
- ✓ 3/4” – 1 1/4” hose connection (with bushings available in Accessories)
- ✓ Drill Point available in Accessories
- ✓ Capable of being used with recycled water

Length	Ø	Inserts	Jets	Min. flowrate	Pipe Ø	Weight
Länge		Einsätze	Winkel	Min. Durchfluss	Arbeitsbereich	Gewicht
4,60“	2,50“	R: 8x M8 ASK / FJ 3x M8 ASK / 0° M10x1 ASK	0°/15°/23°	50 US gallon	6“ - 16“	2,2 lbs



## Speer Düse 1“

Hergestellt aus verschleißfestem, gehärtetem Stahl, durchbohrt und öffnet die Speer Düse mit ihren vier geballten Vorstrahldüsen und scharfen Kanten jede Verstopfung und Vereisung in kurzer Zeit in Rohren mit großen Nennweiten.

### Technische Beschreibung:

- ✓ Schwere Ausführung der Pfeil Düse
- ✓ Auswechselbare Bohrspitze, kann auch mit zusätzlichem Düseneinsatz ausgerüstet werden
- ✓ Auswechselbare VA Düseneinsätze mit Gewinde
- ✓ Wasserabstrahlwinkel hinten 23°
- ✓ Wasserabstrahlwinkel vorne 15°
- ✓ 1 1/4“ Schlauchanschluss mit Adapter möglich (erhältlich in Zubehör)
- ✓ Einsetzbar bei Wasserrückgewinnern (Mit Keramik Düseneinsätzen)



## Spear Nozzle 1“

Precision engineered and manufactured of wear-resistant tempered steel, the Spear Nozzle is a bigger, heavier version of the Chisel Nozzles to cut, break and remove total blockages in no time with its 5 very strong concentrated forward jets, drill point and sharp edges in larger pipes.

### Technical Specifications:

- ✓ Heavy duty construction
- ✓ Drill point can be replaced with additional nozzle insert
- ✓ Replaceable, threaded stainless steel nozzle inserts
- ✓ Rear water jet angle 23°
- ✓ Front water jet angle 15°
- ✓ 1 1/4” hose connection (with bushings available in Accessories)
- ✓ Capable of being used with recycled water

Length	Ø	Inserts	Jets	Min. flowrate	Pipe Ø	Weight
Länge		Einsätze	Winkel	Min. Durchfluss	Arbeitsbereich	Gewicht
7,60“	3“	R: 6x SW14 ASK / FJ 4x M8 ASK / 0° M10x1 ASK	0°/15°/23°	50 US gallon	8“ - 24“	6,2 lbs



## Emperor Düse 1"

Hergestellt aus verschleißfestem, gehärtetem Stahl. Zwei unterschiedliche Wasserabstrahlwinkel von 15° and 30° (jeweils sechs) in Verbindung mit einer innovativen, technisch optimierten Wasserführung verleiht der Emperor Düse eine hervorragende Reinigungsleistung in Rohren mit großen Nennweiten.

### Technische Beschreibung:

- ✓ Einteilige Düse mit optimierter Wasserführung
- ✓ Auswechselbare VA Düseneinsätze mit Gewinde
- ✓ Wasserabstrahlwinkel 15°/30°
- ✓ 1 1/4" Schlauchanschluss mit Adapter möglich (erhältlich in Zubehör)
- ✓ Einsetzbar bei Wasserrückgewinnern (Mit Keramik Düseneinsätzen)



## Emperor Nozzle 1"

Precision engineered and manufactured of wear resistant tempered steel. The Emperor's two different water jet angles of 15 and 30 degrees (six jets each) provide highly effective cleaning performance and traction in large sewer- and stormlines.

### Technical Specifications:

- ✓ Optimized Hydro Mechanics
- ✓ Replaceable, threaded stainless steel nozzle inserts
- ✓ Heavy design for large pipes  
Capable of being used with recycled water
- ✓ Water jet angles 15° and 30°
- ✓ 1 1/4" hose connection (with bushing available in Accessories)

Length	Ø	Inserts	Jets	Min. flowrate	Pipe Ø	Weight
Länge		Einsätze	Winkel	Min. Durchfluss	Arbeitsbereich	Gewicht
7,60"	4,40"	12x SW14 ASK	15°/30°	60 US gallon	12" - 32"	19,9 lbs





## Anti Blower Düse 1"

Hergestellt aus verschleißfestem, gehärtetem Stahl. Der weite Abstrahlwinkel von 36° und die innovative, technisch optimierte Wasserführung in Verbindung mit reduziertem Wasserdruck beim Rückfahren der Düse vermeidet ein Ausblasen von Toiletten.

### Technische Beschreibung:

- ✓ Einteilige Düse mit optimierter Wasserführung
- ✓ Auswechselbare VA Düseneinsätze mit Gewinde
- ✓ Wasserabstrahlwinkel 36°
- ✓ 3/4" und 1 1/4" Schlauchanschluss mit Adapter möglich (erhältlich in Zubehör)
- ✓ Einsetzbar bei Wasserrückgewinnern (Mit Keramik Düseneinsätzen)



## Anti Blower Nozzle 1"

Precision engineered and manufactured of wear resistant tempered steel, the specially designed water jet angle in conjunction with reduced pressure eliminates effectively the blowing of toilets.

### Technical Specifications:

- ✓ Optimized Hydro Mechanics
- ✓ Replaceable, threaded stainless steel nozzle inserts
- ✓ Water jet angle 36°
- ✓ 3/4" – 1 1/4" hose connection (with bushings available in Accessories)

Length	Ø	Inserts	Jets	Min. flowrate	Pipe Ø	Weight
Länge		Einsätze	Winkel	Min. Durchfluss	Arbeitsbereich	Gewicht
6"	3,20"	R: 8x M10x1ASK / FJ M10x1 ISK	36°	50 US gallon	6" - 16"	8,8 lbs



## Superior Düse 1“

Präzise entwickelt und hergestellt aus verschleißfestem, gehärtetem Stahl, besitzt die Superior Düse ein spezielles Design zur Überwindung von Rohrversätzen und Kanalabsenkungen.

Der enge, einzelne Wasserabstrahlwinkel von 12° in Verbindung zu einer innovativen, technisch optimierten Wasserführung sorgt für eine hervorragende Zug- und Reinigungsleistung zur restlosen Beseitigung von Sand, Schlack und Ablagerungen aus Abwasserrohren. Alle Superior Düsen werden mit Vorstrahl und Blinddüseneinsatz (austauschbar) geliefert.

### Technische Beschreibung:

- ✓ Einteilige Düse mit optimierter Wasserführung
- ✓ Auswechselbare VA Düseneinsätze mit Gewinde
- ✓ Wasserabstrahlwinkel 15° und 25°
- ✓ 3/4“ und 1 1/4“ Schlauchanschluss mit Adapter möglich (erhältlich in Zubehör)
- ✓ Einsetzbar bei Wasserrückgewinnern (Mit Keramik Düseneinsätzen)



## Penetrator Nozzle 1“

Precision engineered and manufactured of wear-resistant tempered steel, the Penetrator Nozzle has a specific design to successfully navigate over small voids in the pipe.

The narrow, single 12 degree water jet angle provides tremendous traction and cleaning performance. Each Super Penetrator comes with one forward jet insert and blind plug (interchangeable). Upon request, a pulling eye is available as well.

### Technical Specifications:

- ✓ Optimized Hydro Mechanics
- ✓ Replaceable, threaded stainless steel nozzle inserts
- ✓ Optional front jet
- ✓ Rear water jet angle 12°
- ✓ 3/4” – 1 1/4” hose connection (with bushings available in Accessories)
- ✓ Capable of being used with recycled water

Length	Ø	Inserts	Jets	Min. flowrate	Pipe Ø	Weight
Länge		Einsätze	Winkel	Min. Durchfluss	Arbeitsbereich	Gewicht
8“	3,20“	R: 8x M10x1ASK / FJ M10x1ASK	15°/25°	50 US gallon	6“ - 16“	15.5 lbs



### Stealth Düse 1“

Hergestellt aus verschleißfestem und gehärtetem Stahl. Der Stealth's zwei unterschiedliche Wasserabstrahlwinkel von 12° and 18° (jeweils vier) schaffen eine ideale Abstimmung zwischen Zug- und Reinigungsleistung, wobei die enorme Reinigungsleistung durch eine innovative, technisch optimierten Wasserführung erreicht wird.

Stealth Düsen sind hervorragend geeignet zur rund-um Reinigung von Rohren bis ØDN 600mm

#### Technische Beschreibung:

- ✓ Einteilige Düse mit optimierter Wasserführung
- ✓ Auswechselbare VA Düseneinsätze mit Gewinde
- ✓ Wasserabstrahlwinkel 15° und 25°
- ✓ 3/4“ und 1 1/4“ Schlauchanschluss mit Adapter möglich (erhältlich in Zubehör)
- ✓ Einsetzbar bei Wasserrückgewinnern (Mit Keramik Düseneinsätzen)



### Stealth Nozzle 1“

Precision engineered and manufactured of wear-resistant tempered steel. The Stealth's two different jet angles of 12 and 18 degrees (four jets each) provide powerful traction and effective cleaning performance to remove sand, silt and obstruction from sewer- or stormlines.

#### Technical Specifications:

- ✓ Optimized Hydro Mechanics
- ✓ Replaceable, threaded stainless steel nozzle inserts
- ✓ Capable of being used with recycled water
- ✓ Rear water jet angles 12° and 18°
- ✓ 1 1/4” hose connection (with bushings available in Accessories)

Length	Ø	Inserts	Jets	Min. flowrate	Pipe Ø	Weight
Länge		Einsätze	Winkel	Min. Durchfluss	Arbeitsbereich	Gewicht
7,6“	4“	8x SW14 ASK	12°/18°	60 US gallon	8“ - 24“	17.7 lbs



**Fly Düse 1“**

Präzise entwickelt und hergestellt aus verschleißfestem und gehärtetem Stahl, ist die Fly Düse ein hervorragendes hydrodynamisches Werkzeug für sehr hohe Anwendungsansprüche. Der enge, einzelne Wasserabstrahlwinkel von 7° in Verbindung mit einer innovativen, technisch optimierten Wasserführung sorgt für eine hervorragende Zug- und Reinigungsleistung, die insbesondere in langen Rohrleitungen und hügeligen Gelände zu ihrer Geltung kommt.

**Technische Beschreibung:**

- ✓ Einteilige Düse mit optimierter Wasserführung
- ✓ Auswechselbare VA Düseneinsätze mit Gewinde
- ✓ Wasserabstrahlwinkel 7°
- ✓ 3/4“ und 1 1/4“ Schlauchanschluss mit Adapter möglich (erhältlich in Zubehör)
- ✓ Einsetzbar bei Wasserrückgewinnern (Mit Keramik Düseneinsätzen)

**Power Pull Nozzle 1“**

Precision engineered and manufactured of wear-resistant tempered steel, the Power Pull Nozzle is an ideal tool for some of the toughest applications. The narrow, single 7 degree jet angle provides tremendous traction and cleaning performance in mountainous, difficult terrain. Great nozzle to clean and remove sand, silt and large debris from sewer lines.

**Technical Specifications:**

- ✓ Optimized Hydro Mechanics
- ✓ Replaceable, threaded stainless steel nozzle inserts
- ✓ Rear water jet angle 7°
- ✓ Capable of being used with recycled water

Length	Ø	Inserts	Jets	Min. flowrate	Pipe Ø	Weight
Länge		Einsätze	Winkel	Min. Durchfluss	Arbeitsbereich	Gewicht
6“	3,2“	8x M10x1ASK	7°	50 US gallon	6“ - 16“	8.8 lbs



## General Düse 1“

Hergestellt aus verschleißfestem, gehärtetem Stahl, werden die General Düsen mit Vorstrahl und Blinddüseneinsatz (austauschbar) geliefert. Sie ist hervorragend geeignet zum Einsatz bei präventativer Wartung und zur Rundumreinigung der Kanalisation.

Zwei unterschiedliche Wasserabstrahlwinkel - 15° and 25° - bei jeweils vier VA Düseneinsätzen schaffen eine ideale Abstimmung zwischen Zug- und Reinigungsleistung, wobei die enorme Reinigungsleistung durch eine innovative, technisch optimierte Wasserführung erreicht wird.

### Technische Beschreibung:

- ✓ Einteilige Düse mit optimierter Wasserführung
- ✓ Auswechselbare VA Düseneinsätze mit Gewinde
- ✓ Wasserabstrahlwinkel 15° und 25°
- ✓ 3/4“ und 1 1/4“ Schlauchanschluss mit Adapter möglich (erhältlich in Zubehör)
- ✓ Einsetzbar bei Wasserrückgewinnern (Mit Keramik Düseneinsätzen)

## General Nozzle 1“

Precision engineered and manufactured of wear-resistant tempered steel with one forward jet and blind plug (interchangeable) included, the General is a perfect nozzle for preventative maintenance and all-around sewer cleaning.

Two different water jet angles - 15 and 25 degrees - (four jets each) provide strong traction and highly efficient cleaning.

### Technical Specifications:

- ✓ Optimized Hydro Mechanics
- ✓ Replaceable, threaded stainless steel nozzle inserts
- ✓ Rear water jet angles 15° and 25°
- ✓ 3/4“ and 1 1/4“ bushings available in Accessories
- ✓ Capable of being used with recycled water

Length	Ø	Inserts	Jets	Min. flowrate	Pipe Ø	Weight
Länge		Einsätze	Winkel	Min. Durchfluss	Arbeitsbereich	Gewicht
6“	3,2“	R: 8x M10x1ASK / FJ M10x1 ISK	15°/25°	50 US gallon	6“ - 16“	8.8 lbs



### Fly Düse LRG 1“

Präzise entwickelt und hergestellt aus verschleißfestem und gehärtetem Stahl, ist die Fly Düse ein hervorragendes hydrodynamisches Werkzeug für sehr hohe Anwendungsansprüche. Der enge, einzelne Wasserabstrahlwinkel von 7° in Verbindung mit einer innovativen, technisch optimierten Wasserführung sorgt für eine hervorragende Zug- und Reinigungsleistung, die insbesondere in langen Rohrleitungen und hügeligen Gelände zu ihrer Geltung kommt.

#### Technische Beschreibung:

- ✓ Einteilige Düse mit optimierter Wasserführung
- ✓ Auswechselbare VA Düseneinsätze mit Gewinde
- ✓ Wasserabstrahlwinkel 7°
- ✓ 3/4“ und 1 1/4“ Schlauchanschluss mit Adapter möglich (erhältlich in Zubehör)
- ✓ Einsetzbar bei Wasserrückgewinnern (Mit Keramik Düseneinsätzen)



### Power Pull Nozzle LRG 1“

Precision engineered and manufactured of wear-resistant tempered steel, the Power Pull Nozzle is an ideal tool for some of the toughest applications. The narrow, single 7 degree jet angle provides tremendous traction and cleaning performance in mountainous, difficult terrain. Great nozzle to clean and remove sand, silt and large debris from sewer lines.

#### Technical Specifications:

- ✓ Optimized Hydro Mechanics
- ✓ Replaceable, threaded stainless steel nozzle inserts
- ✓ Rear water jet angle 7°
- ✓ Capable of being used with recycled water

Length	Ø	Inserts	Jets	Min. flowrate	Pipe Ø	Weight
Länge		Einsätze	Winkel	Min. Durchfluss	Arbeitsbereich	Gewicht
7,60“	4“	8x SW14 ASK	7°	60 US gallon	8“ - 24“	17,0 lbs



## Standard Düse 1“

Präzise entwickelt und hergestellt aus verschleißfestem, gehärtetem Stahl, alle Standard Reinigungsdüsen werden mit Vorstrahl und zusätzlichem Blinddüseneinsatz (austauschbar) geliefert. Der Abstrahlwinkel beträgt 23°. Die Standard Reinigungsdüse ist ideal zur Beseitigung von Sand, Schlack und weichen Ablagerungen.

### Technische Beschreibung:

- ✓ Auswechselbare VA Düseneinsätze mit Gewinde
- ✓ Optionaler Vorstrahl oder Blinddüseneinsatz bei Kamerabefahrung des Kanals
- ✓ Einsetzbar bei Wasserrückgewinnern
- ✓ Wasserabstrahlwinkel 23°



## Standard Nozzle 1“

Precision engineered and manufactured of wear-resistant tempered steel, each Standard Nozzle includes one forward jet and blind plug (interchangeable). Jet angle is 23 degree. The Standard Cleaning Nozzle is light, maneuverable and highly efficient.

### Technical Specifications:

- ✓ Replaceable, threaded stainless steel nozzle inserts
- ✓ Optional front jet
- ✓ Capable of being used with recycled water
- ✓ Rear water jet angle 23°

Length	Ø	Inserts	Jets	Min. flowrate	Pipe Ø	Weight
Länge		Einsätze	Winkel	Min. Durchfluss	Arbeitsbereich	Gewicht
3,20"	2,4"	R: 8x M6 ISK / FJ M6 ISK	23°	40 US gallon	6" - 10"	2,0 lbs

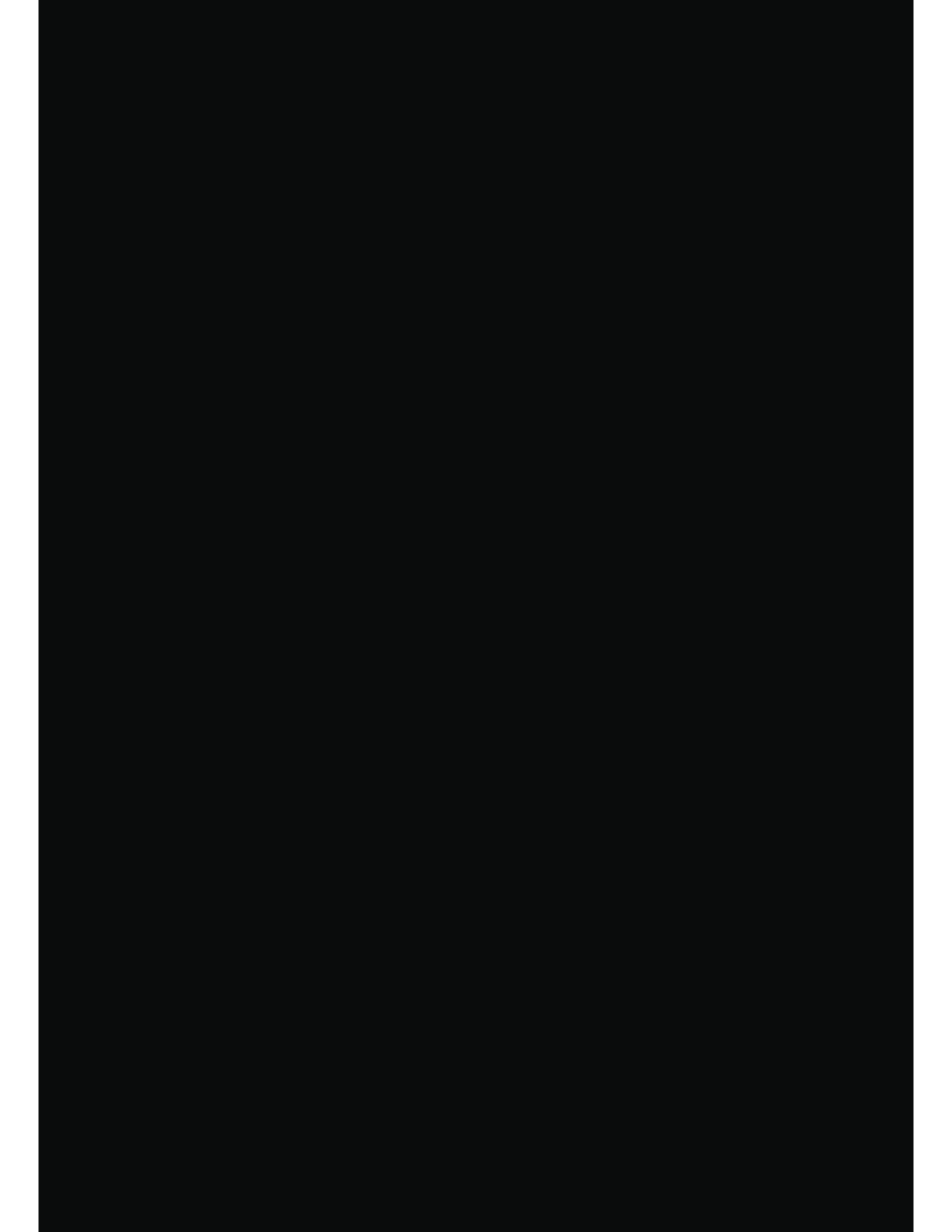



# **WARTHOG**

SEWER NOZZLES BY **STONEAGE**®



SEWER NOZZLES & ACCESSORIES

**NEW!**  
**WHR SWITCHER™**  
THE INDUSTRY'S MOST REVOLUTIONARY NOZZLE

PAGE #10





**HIGH-SPEED ROTATION  
COMBINED WITH LOW  
MAINTENANCE MAKE  
THE WV A POWERFUL  
TOOL FOR 2"-4" LINES.**

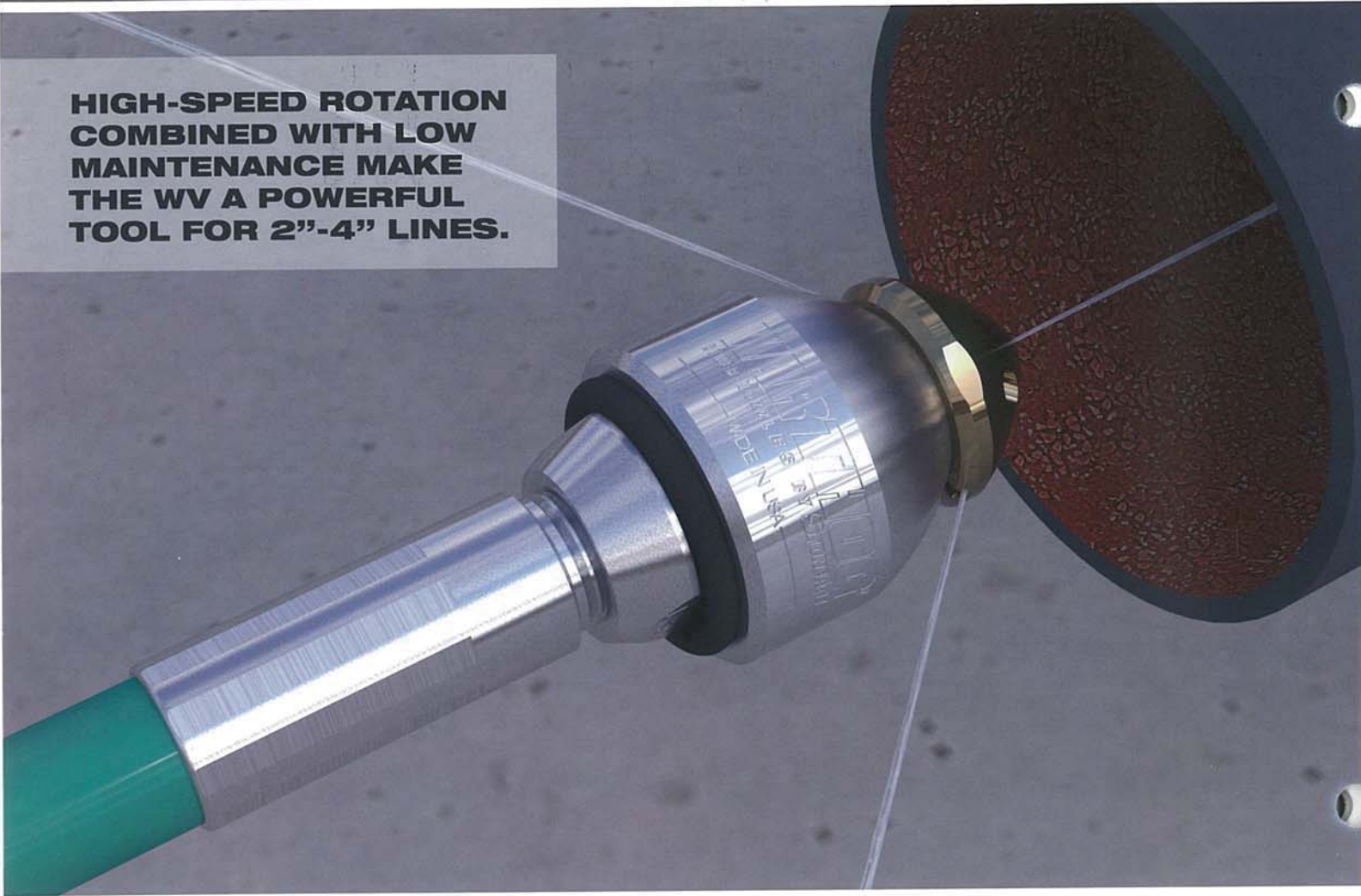

## WV-1/4-LK

2"-4" (51-102 mm) Lines with Elbows

The WV-1/4-LK uses StoneAge's flow-through technology and features a revolutionary high-speed rotating design with no high pressure seals or bearings to service. It cleans lines as small as 2" (51 mm) with long sweeping elbows. The head design also features permanent, pre-drilled orifices rather than threaded nozzles.

The tool operates from 2-5k psi (140-350 bar) and 3-8 gpm (11-30 l/min). It has a 1/4" NPT pipe thread inlet and can pass through long radius elbows in lines 2" (51 mm) and larger if a 1/4" NPT hose fitting is used.

### WV-1/4-LK Tool Head Options

PART #	FRONT JET	BACK JETS	FLOW
WV-1/4-LK-A	0.024 in. 0.6 mm	2 x .052 in. 1.3 mm	7-8 gpm 26-30 l/min
WV-1/4-LK-B	0.020 in. 0.5 mm	2 x .039 in. 1.0 mm	5-6 gpm 19-23 l/min
WV-1/4-LK-C	0.018 in. 0.45 mm	2 x .032 in. 0.8 mm	4-4.5 gpm 15-17 l/min
WV-1/4-LK-D	0.018 in. 0.45 mm	2 x .028 in. 0.7 mm	3-3.5 gpm 11-13 l/min

### WV-1/4-LK

2"-4" Lines (51-102 mm)

Up to 5k psi (350 bar)

3-8 gpm Flows (11-30 l/min)

High-Speed Rotation

### WV-1/4-LK Specifications

<b>MAXIMUM PRESSURE</b>	5k psi 350 bar
<b>OPERATING PRESSURE</b>	2-5k psi 140-350 bar
<b>FLOW</b>	3-8 gpm 11.4-30.3 l/min
<b>FLOW RATING</b>	0.8 Cv
<b>PULLING FORCE</b>	4-9 lb 40 N
<b>INLET CONNECTION</b>	1/4 NPT or BSPP
<b>TOOL DIAMETER</b>	1.3 in. 33 mm
<b>LENGTH</b>	2.0 in. 51 mm
<b>NOZZLE PORTS</b>	3 Drilled
<b>WEIGHT COMPLETE</b>	0.45 lb 0.20 kg

# WV-1/4-LK

Exploded View - Part Names and Numbers

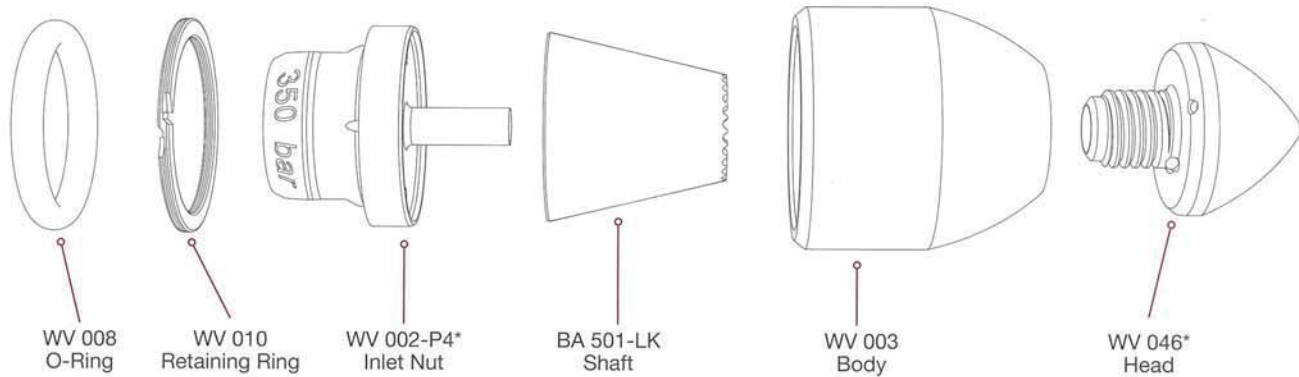

\*See charts on the opposite page for inlet nut and head options.  
 This is a low-maintenance tool. There are no maintenance or overhaul kits. However, the **WV 612** tool kit is available for easy tool disassembly.

## POTENTIAL HAZARD!

*If any Warthog is being used in pipes larger than the recommended diameter, a rigid stinger with a minimum length of 1.5 times the diameter of the pipe I.D. should be installed between the tool inlet and the hose end. Otherwise the tool can turn around inside the line (as shown here) and come back toward the operator, causing serious injury or death.*

**STONEAGE CARRIES A COMPLETE LINE OF STINGERS AND CAN HELP YOU PROPERLY SELECT THE RIGHT ONE FOR YOUR APPLICATION.**



## ◀ CORRECT

This is an example of **WV-1/4-LK** set up for correct usage in pipes larger than 4" (102 mm) in diameter. A rigid Stinger should be installed between the tool inlet and the hose end. This helps to prevent the tool from turning around inside of the pipe and coming back toward the operator.



**EXTENDED LIFE CARBIDE  
BUTTONS, STANDARD ON  
EVERY MODEL.**

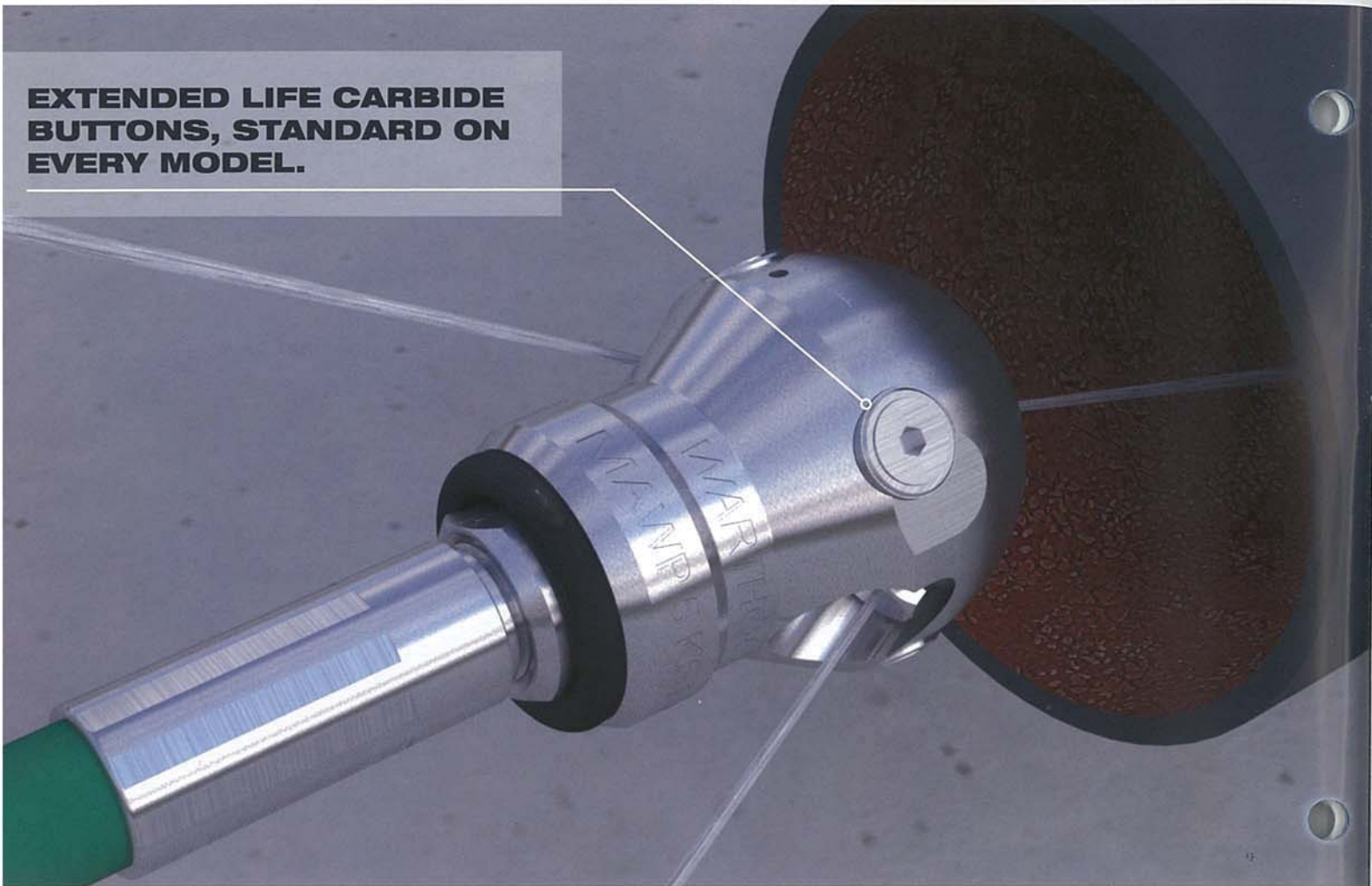

## WT-3/8-C CLASSIC

3"-6" (76-152 mm) Lines with Elbows

Our smaller Classic series models can negotiate elbows and clean-outs commonly found in laterals at homes, buildings, restaurants and other light commercial facilities. This tool is most commonly used on small capacity pumps and cart jetters. Also an excellent choice for cutting roots, clearing ice and removing blockages.

Pipes made of cast iron and those that have sand or silt can act as abrasive agents that can aggressively wear out the tool. We've added permanent carbide buttons to the WT-3/8-C to increase head life. Our carbide buttons are available in all offsets and add up to 5 times the life compared to previous WT-3/8 models. It also features replaceable AP2 nozzles.

<b>WT-3/8-C</b> 3"-6" Lines (76-152 mm)	Up to 5k psi (350 bar)
	5-12 gpm Flows (20-45 l/min)
	Classic Workhorse Model

### WT-3/8-C Specifications

<b>MAXIMUM PRESSURE</b>	5k psi	350 bar
<b>OPERATING PRESSURE</b>	1500-5k psi	100-350 bar
<b>ROTATION SPEED</b>	300-500 rpm	
<b>FLOW</b>	5-12 gpm	20-45 l/min
<b>FLOW RATING</b>	0.75 Cv	
<b>PULLING FORCE</b>	5-20 lb	22-90 N
<b>INLET CONNECTION</b>	3/8 NPT or BSPP	
<b>TOOL DIAMETER</b>	1.9 in.	48 mm
<b>LENGTH</b>	3.0 in.	76 mm
<b>NOZZLE PORTS</b>	3 x 1/8 NPT	
<b>WEIGHT COMPLETE</b>	1.2 lb	.54 kg

## WT-3/8-C

Exploded View - Part Names and Numbers

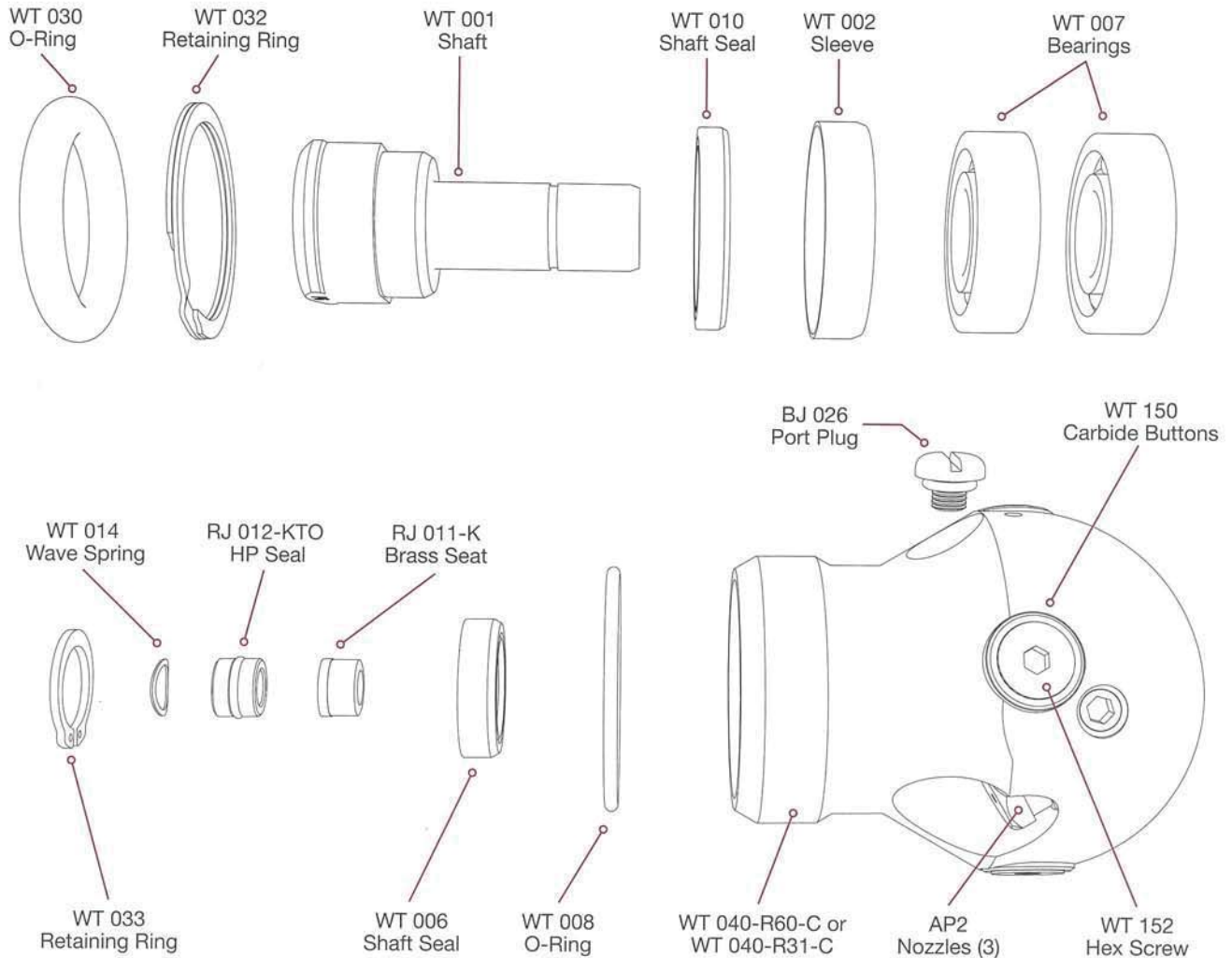

### Maintenance & Overhaul Kits

#### WT 600 • SERVICE KIT

<b>(1) BC 410</b>	Syringe Assembly
<b>(1) BJ 026</b>	Port Plug
<b>(1) BJ 048-S</b>	Visc. Fluid, 6oz.
<b>(1) BJ 062-S</b>	Antiseize, 2g
<b>(1) GP 025-P2SS</b>	Hex Socket Plug
<b>(1) RJ 011-K</b>	Brass Seat
<b>(1) RJ 012-KTO</b>	HP Seal & O-Ring
<b>(1) WT 014</b>	Wave Spring

#### WT 602 • SEAL KIT

<b>(1) RJ 011-K</b>	Brass Seat
<b>(1) RJ 012-KTO</b>	HP Seal & O-Ring
<b>(1) WT 014</b>	Wave Spring

#### WT 610 • OVERHAUL KIT

<b>(1) BJ 026</b>	Port Plug
<b>(1) BJ 048-S</b>	Visc. Fluid, 6oz.
<b>(1) RJ 011-K</b>	Brass Seat
<b>(1) RJ 012-KTO</b>	HP Seal & O-Ring
<b>(1) WT 006</b>	Seal
<b>(2) WT 007</b>	Bearing, Ball
<b>(1) WT 008</b>	O-Ring
<b>(1) WT 010</b>	Seal
<b>(1) WT 014</b>	Wave Spring
<b>(1) WT 032</b>	Retaining Ring
<b>(1) WT 030</b>	O-Ring

#### WT 612 • TOOL KIT

<b>(1) BA 100</b>	Retaining Ring Pliers
<b>(1) WT 105</b>	Tool



**PERFECT FOR SMALL  
CAPACITY COMBINATION  
TRUCKS AND LARGE  
TRAILER JETTERS.**

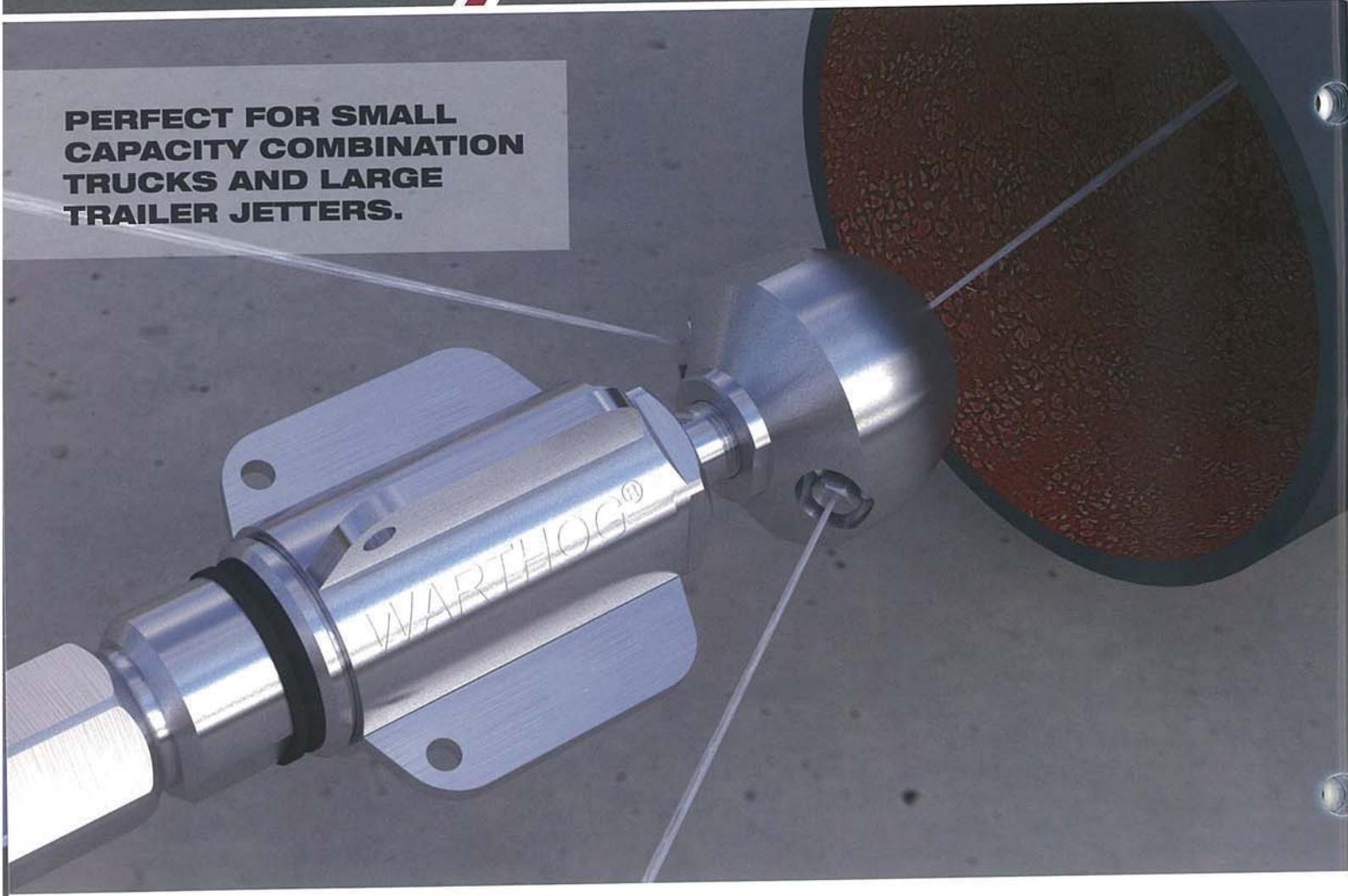

## WH-1/2 & WH-3/4 CLASSIC

6"-18" (152-457 mm) Lines

The WH-1/2 and the WH-3/4 are the same tool offered with different inlet ports, either 1/2" or 3/4" NPT or BSPP. The WH models are best for 6"-18" (152-457 mm) lines.

These tools are most commonly used with small capacity combination trucks and large trailer jetters. Descaling Heads are available for both models.

### WH-1/2 & 3/4

6"-18" Lines (152-457 mm)

Up to 8k psi (550 bar)

10-45 gpm Flows (40-170 l/min)

Two Inlet Options Available

### WH-1/2 & WH-3/4 Specifications

<b>MAXIMUM PRESSURE</b>	8k psi (550 bar)
<b>OPERATING PRESSURE</b>	1500-8k psi (100-550 bar)
<b>ROTATION SPEED</b>	(150-300 rpm)
<b>FLOW</b>	10-50 gpm (40-170 l/min)
<b>FLOW RATING</b>	2.6 Cv
<b>PULLING FORCE</b>	18-50 lb (80-220 N)
<b>INLET CONNECTION</b>	1/2 NPT or BSPP & 3/4 NPT or BSPP
<b>LENGTH</b>	7.5 in. (191 mm)
<b>DIAMETER INCL. CENT.</b>	3.4 in. (86 mm)
<b>NOZZLE PORTS</b>	3 x 1/8 NPT
<b>WEIGHT COMPLETE</b>	4.7 lb 2.1 kg

Optional Descaling Head  
for the WH-1/2 & WH-3/4

**WH 040-DS**

**TECH TIP: WE RECOMMEND  
PLUGGING THE FRONT JET TO HELP  
MAXIMIZE DESCALING AND PULLING  
POWER WHEN USING THIS OPTION.**



## WS-1/2

Exploded View - Part Names and Numbers

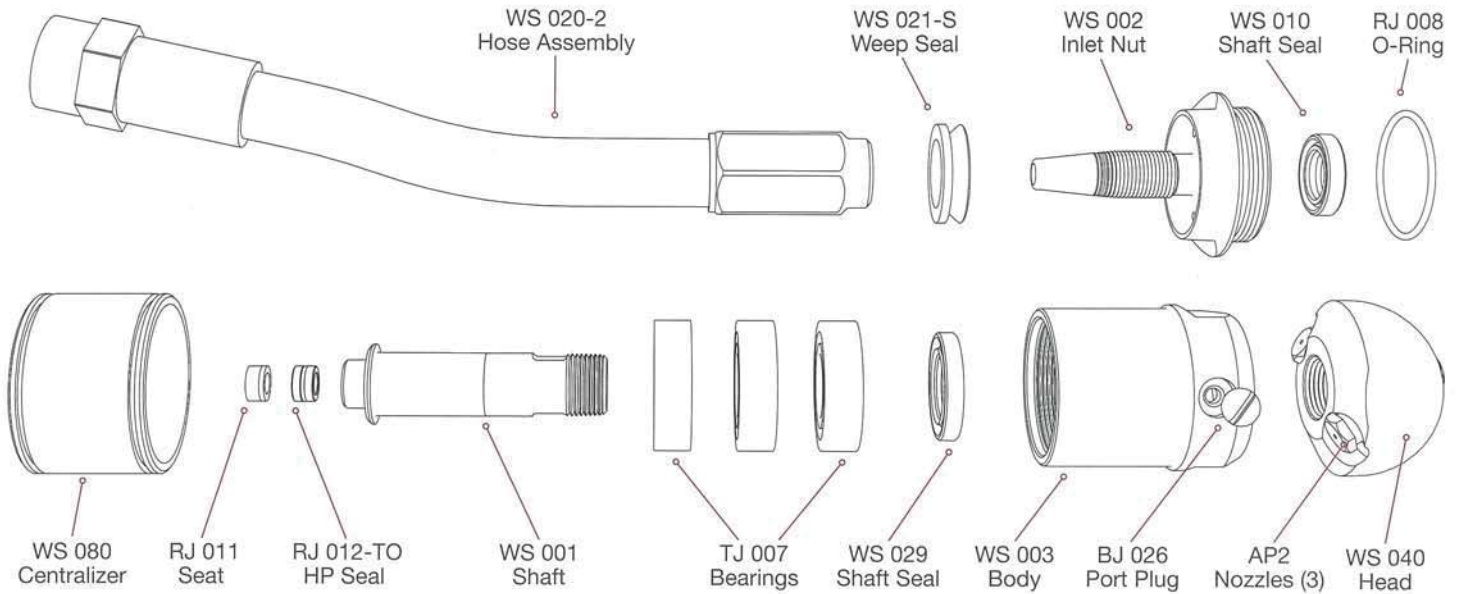

## WS-1/2-J

Inlet Area Parts

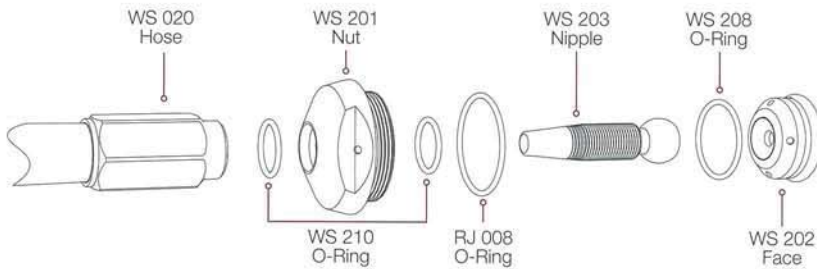

## WS-P8

Inlet Area Parts

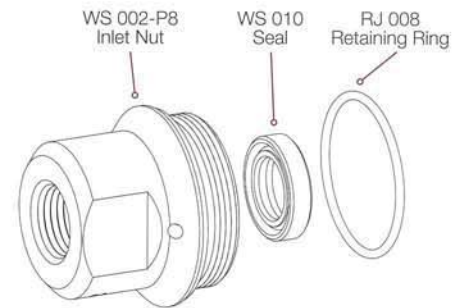

## Maintenance & Overhaul Kits

### WS 600 • SERVICE KIT

- (1) **BC 410** Syringe Assembly
- (1) **BJ 048-S** Visc. Fluid, 6oz.
- (1) **BJ 062-S** Antiseize, 2g
- (1) **GP 025-P2** Hex Socket Plug
- (1) **RJ 011** Brass Seat
- (1) **RJ 012-TO** HP Seal & O-Ring

### WS 610 • OVERHAUL KIT

- (1) **BJ 026** Port Plug
- (1) **BJ 048-S** Visc. Fluid, 6oz.
- (1) **BJ 062-S** Antiseize, 2g
- (1) **RJ 008** O-Ring
- (1) **RJ 011** Brass Seat
- (1) **RJ 012-TO** HP Seal & O-Ring
- (3) **TJ 007** Ball Bearings
- (1) **WS 010** Small Seal
- (1) **WS 021-S** Weep Seal
- (1) **WS 029** Large Seal

### WS 610-J • OVERHAUL KIT

- (1) **BJ 026** Port Plug
- (1) **BJ 048-S** Visc. Fluid, 6oz.
- (1) **BJ 062-S** Antiseize, 2g
- (1) **RJ 008** O-Ring
- (1) **RJ 011** Brass Seat
- (1) **RJ 012-TO** HP Seal & O-Ring
- (3) **TJ 007** Ball Bearings
- (1) **WS 010** Small Seal
- (1) **WS 029** Large Seal
- (1) **WS 208** O-Ring
- (2) **WS 210** O-Rings

### WS 612 • TOOL KIT

- (1) **TJ 064** Fill Tube
  - (1) **WS 105** Tool
- ### WS 602 • SEAL KIT
- (1) **RJ 011** Brass Seal
  - (1) **RJ 012-TO** HP Seal & O-Ring



**THE WHP-3/4 IS  
EXCELLENT FOR  
LONGER LINES AND  
MODERATE INCLINES.**



## WHP-3/4 CLASSIC

6"-18" (152-457 mm) Lines with Elbows

The WHP-3/4 has been designed to produce more pulling power than other tools available on the market. The centralizer fins are streamlined to allow the rear facing jets to be angled more sharply, giving the tool more forward thrust. The result is more pulling power to handle longer lines and moderate inclines.

The WHP-3/4 features 3 nozzle ports, including a boring jet offset at 15 degrees, and 2 rear jets at 18 degrees. The inlet port comes in either 3/4" NPT or BSPP.

<b>WHP-3/4</b> 6"-18" Lines (152-457 mm)	Up to 8k psi (550 bar)
	15-50 gpm Flows (60-190 l/min)
	Up to 20% More Thrust*

### WHP-3/4 Specifications

<b>MAXIMUM PRESSURE</b>	8k psi 550 bar
<b>OPERATING PRESSURE</b>	1500-4k psi 00-275 bar
<b>ROTATION SPEED</b>	150-300 rpm
<b>FLOW</b>	15-50 gpm 60-190 l/min
<b>FLOW RATING</b>	3.0 Cv
<b>PULLING FORCE</b>	45-90 lb 00-400 Nm
<b>INLET PORT</b>	1/2 NPT, 1/2 BSPP, 3/4 NPT, 3/4 BSPP
<b>DIA. INCLUDING CENTRALIZER</b>	3.4 in. 86 mm
<b>LENGTH</b>	7.5 in. 190 mm
<b>NOZZLE PORTS</b>	3 x 1/8 NPT
<b>WEIGHT COMPLETE</b>	4.7 lb 2.1 kg

\* With the front jet plugged.



## WH-1/2 & WH-3/4

Exploded View - Part Names and Numbers

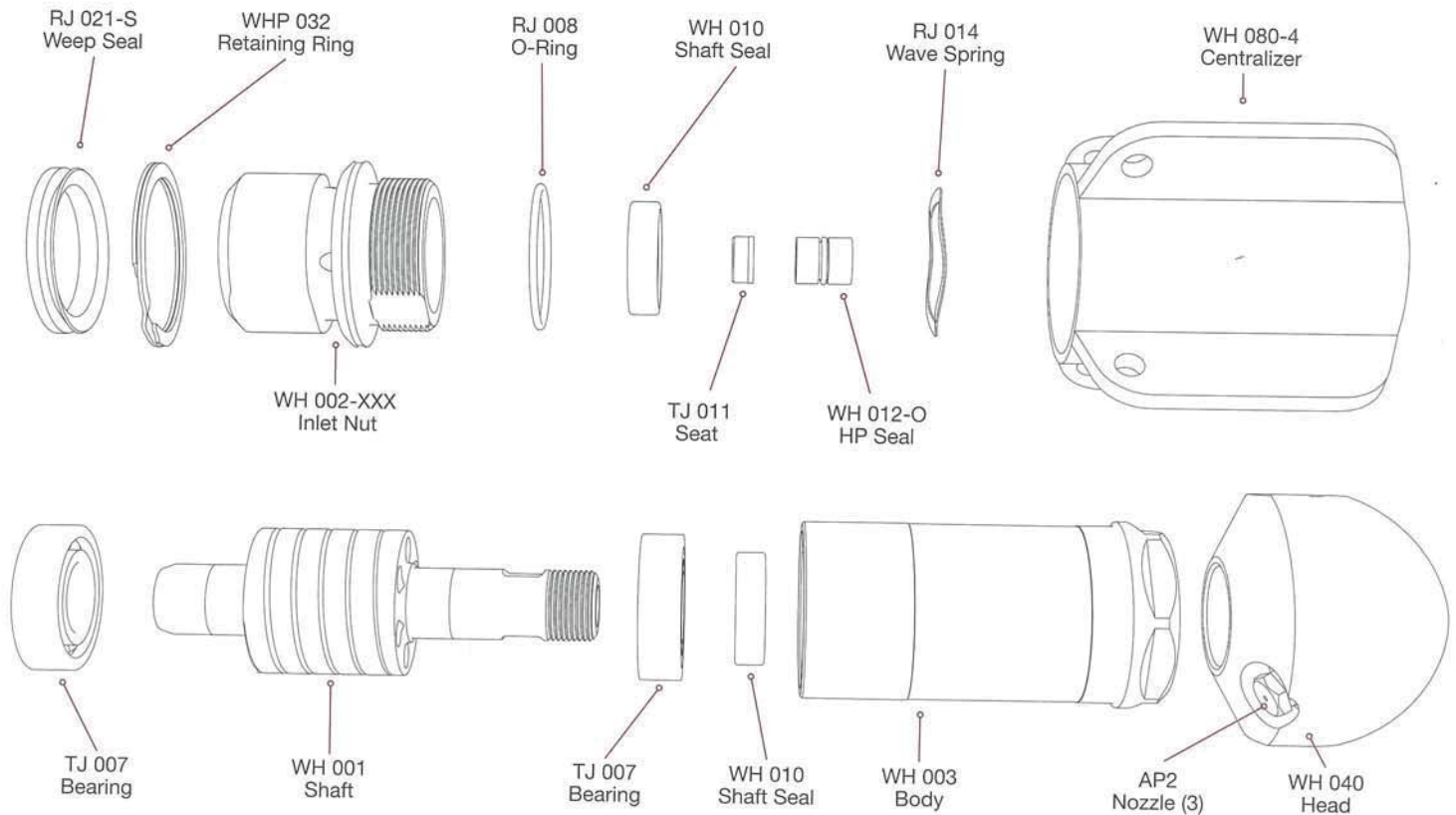

### Maintenance & Overhaul Kits

#### WH 600 • SERVICE KIT

- (1) BJ 048-F Viscous Fluid, 6oz.
- (1) BJ 062-S Antiseize, 2g
- (1) GP 025-P2SS Hex Socket Plug
- (1) TJ 011 Brass Seat
- (1) WH 012-O HP Seal & O-Ring

#### WH 602 • SEAL KIT

- (1) TJ 011 Brass Seat
- (1) WH 012-O HP Seal & O-Ring

#### WH 610 • OVERHAUL KIT

- (1) BJ 048-F Viscous Fluid, 6oz.
- (1) BJ 062-S Antiseize, 2g
- (1) RJ 008 O-Ring
- (1) TJ 011 Brass Seat
- (1) WH 012-O HP Seal & O-Ring
- (2) TJ 007 Ball Bearing
- (2) WH 010 Shaft Seal
- (1) RJ 021-S Weep Seal
- (1) RJ 014 Wave Spring

#### WH 612 • TOOL KIT

- (1) TJ 064 Fill Tube
- (1) WH 105 Tool



**THE WHP-3/4 IS  
EXCELLENT FOR  
LONGER LINES AND  
MODERATE INCLINES.**



## WHP-3/4 CLASSIC

6"-18" (152-457 mm) Lines with Elbows

The WHP-3/4 has been designed to produce more pulling power than other tools available on the market. The centralizer fins are streamlined to allow the rear facing jets to be angled more sharply, giving the tool more forward thrust. The result is more pulling power to handle longer lines and moderate inclines.

The WHP-3/4 features 3 nozzle ports, including a boring jet offset at 15 degrees, and 2 rear jets at 18 degrees. The inlet port comes in either 3/4" NPT or BSPP.

<b>WHP-3/4</b> 6"-18" Lines (152-457 mm)	Up to 8k psi (550 bar)
	15-50 gpm Flows (60-190 l/min)
	Up to 20% More Thrust*

### WHP-3/4 Specifications

<b>MAXIMUM PRESSURE</b>	8k psi 550 bar
<b>OPERATING PRESSURE</b>	1500-4k psi 00-275 bar
<b>ROTATION SPEED</b>	150-300 rpm
<b>FLOW</b>	15-50 gpm 60-190 l/min
<b>FLOW RATING</b>	3.0 Cv
<b>PULLING FORCE</b>	45-90 lb 00-400 Nm
<b>INLET PORT</b>	1/2 NPT, 1/2 BSPP, 3/4 NPT, 3/4 BSPP
<b>DIA. INCLUDING CENTRALIZER</b>	3.4 in. 86 mm
<b>LENGTH</b>	7.5 in. 190 mm
<b>NOZZLE PORTS</b>	3 x 1/8 NPT
<b>WEIGHT COMPLETE</b>	4.7 lb 2.1 kg

\* With the front jet plugged.

## WHP-3/4

Exploded View - Part Names and Numbers

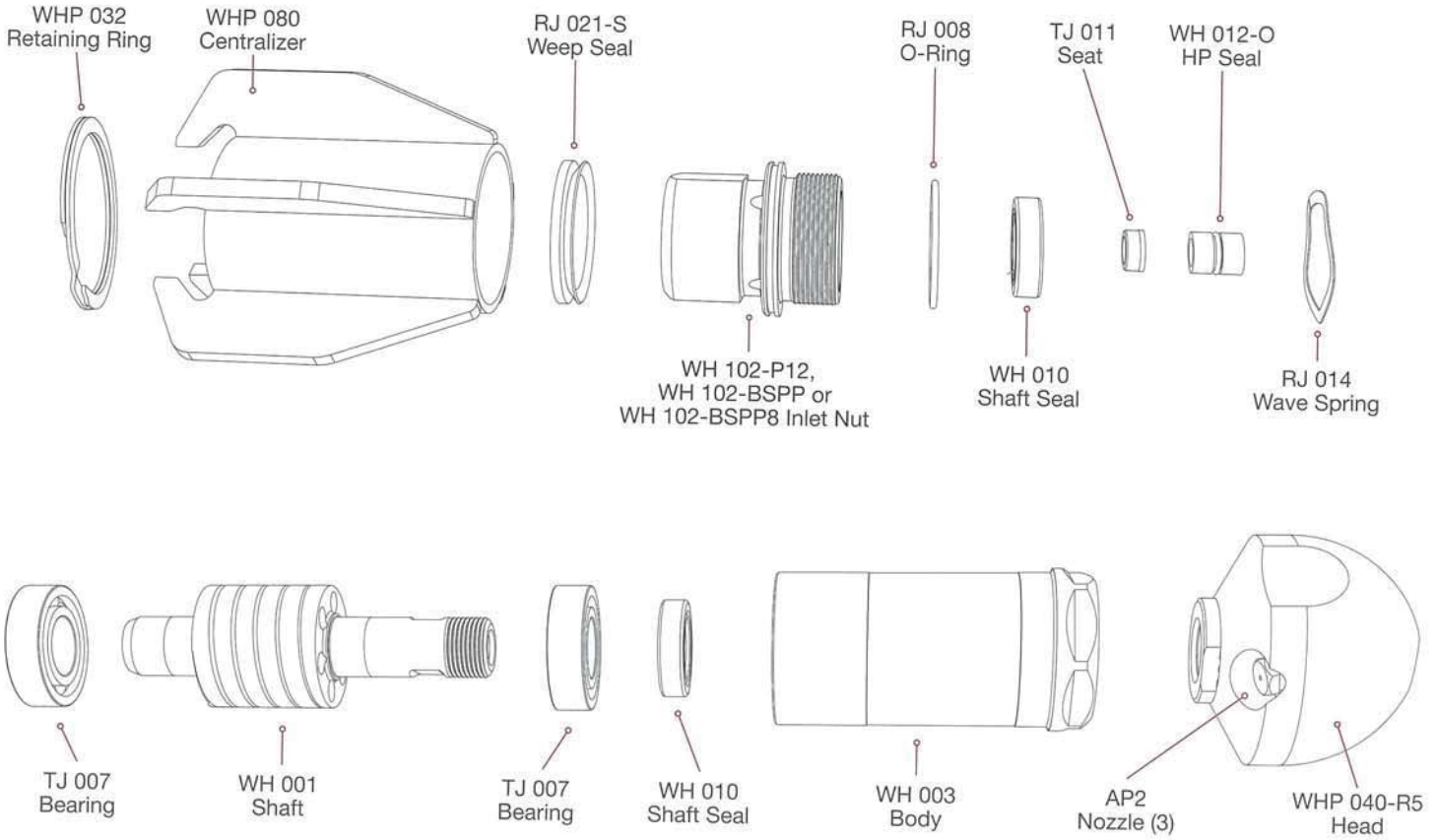

## Maintenance & Overhaul Kits

### WH 600 • SERVICE KIT

- (1) BJ 048-F Visc. Fluid Fast, 6oz.
- (1) BJ 062-S Antiseize, 2g
- (1) GP 025-P2SS Hex Socket Plug
- (1) TJ 011 Brass Seat
- (1) WH 012-0 HP Seal & O-Ring

### WH 602 • SEAL KIT

- (1) TJ 011 Brass Seat
- (1) WH 012-0 HP Seal & O-Ring

### WH 610 • OVERHAUL KIT

- (1) BJ 048-F Visc. Fluid Fast, 6oz.
- (1) BJ 062-S Antiseize, 2g
- (1) RJ 008 O-Ring
- (1) TJ 011 Brass Seat
- (1) WH 012-0 HP Seal & O-Ring
- (2) TJ 007 Ball Bearing
- (2) WH 010 Shaft Seal
- (1) RJ 021-S Weep Seal
- (1) RJ 014 Wave Spring
- (1) WHP 032 Retaining Ring

### WH 612 • TOOL KIT

- (1) TJ 064 Fill Tube
- (1) WH 105 Tool



**OUR CLASSIC WG-1  
MODEL IS A MUNICIPAL  
WORKHORSE**

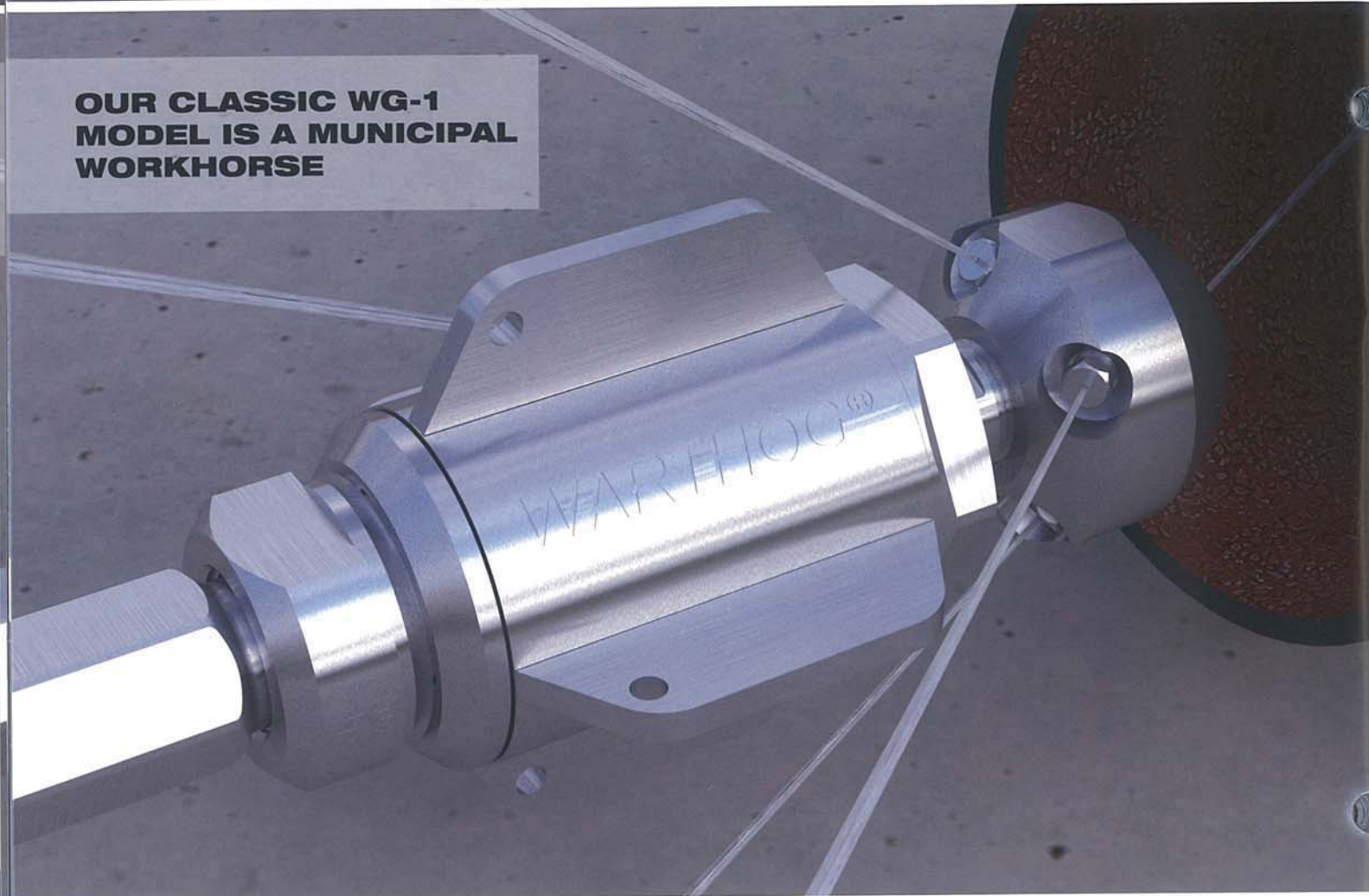

## WG-1 CLASSIC

8"-36" (203-914 mm) Lines

The WG-1 is the proven choice for municipal, industrial and commercial drain cleaning applications. Predominately used in large combination trucks with 1" (25 mm) hose, the WG-1 is field-maintainable for low cost of ownership and can be fitted with replaceable AP2 nozzle tips sized to maximize pump efficiency and effectiveness.

- **CONTROLLED ROTATION**  
Slower dwell time allows jets to penetrate deeper through deposits
- **MULTIPLE HEAD OPTIONS**  
Customize tool for unplugging, descaling or manhole cleaning
- **HIGHEST QUALITY JETS**  
Hardened stainless steel orifices resist cracking and scratching

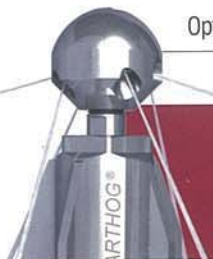

Optional Descaling Head for the WG-1

**WG 040-DS-R5**

**TECH TIP: WE RECOMMEND  
PLUGGING THE FRONT JET TO HELP  
MAXIMIZE DESCALING AND PULLING  
POWER WHEN USING THIS OPTION.**

### WG-1 CLASSIC

	Up to 5k psi (350 bar)
	50-80 gpm Flows (190-300 l/min)
8"-36" Lines (203-914 mm)	Classic WG-1 Model

### WG-1 Specifications

<b>MAXIMUM PRESSURE</b>	5k psi 350 bar
<b>OPERATING PRESSURE</b>	1500-5k psi 100-350 bar
<b>ROTATION SPEED</b>	150-300 rpm
<b>FLOW</b>	50-80 gpm 190-300 l/min
<b>FLOW RATING</b>	4.6 Cv
<b>PULLING FORCE</b>	70-100 lb 310-450 Nm
<b>INLET CONNECTION</b>	1 NPT or BSPP
<b>NOZZLE PORTS</b>	5 x 1/8 NPT (P2)
<b>LENGTH</b>	9.1 in. 231 mm
<b>DIAMETER</b>	4.8 in. 122 mm
<b>WEIGHT COMPLETE</b>	10.9 lb 4.9 kg

## WG-1 CLASSIC

Exploded View - Part Names and Numbers

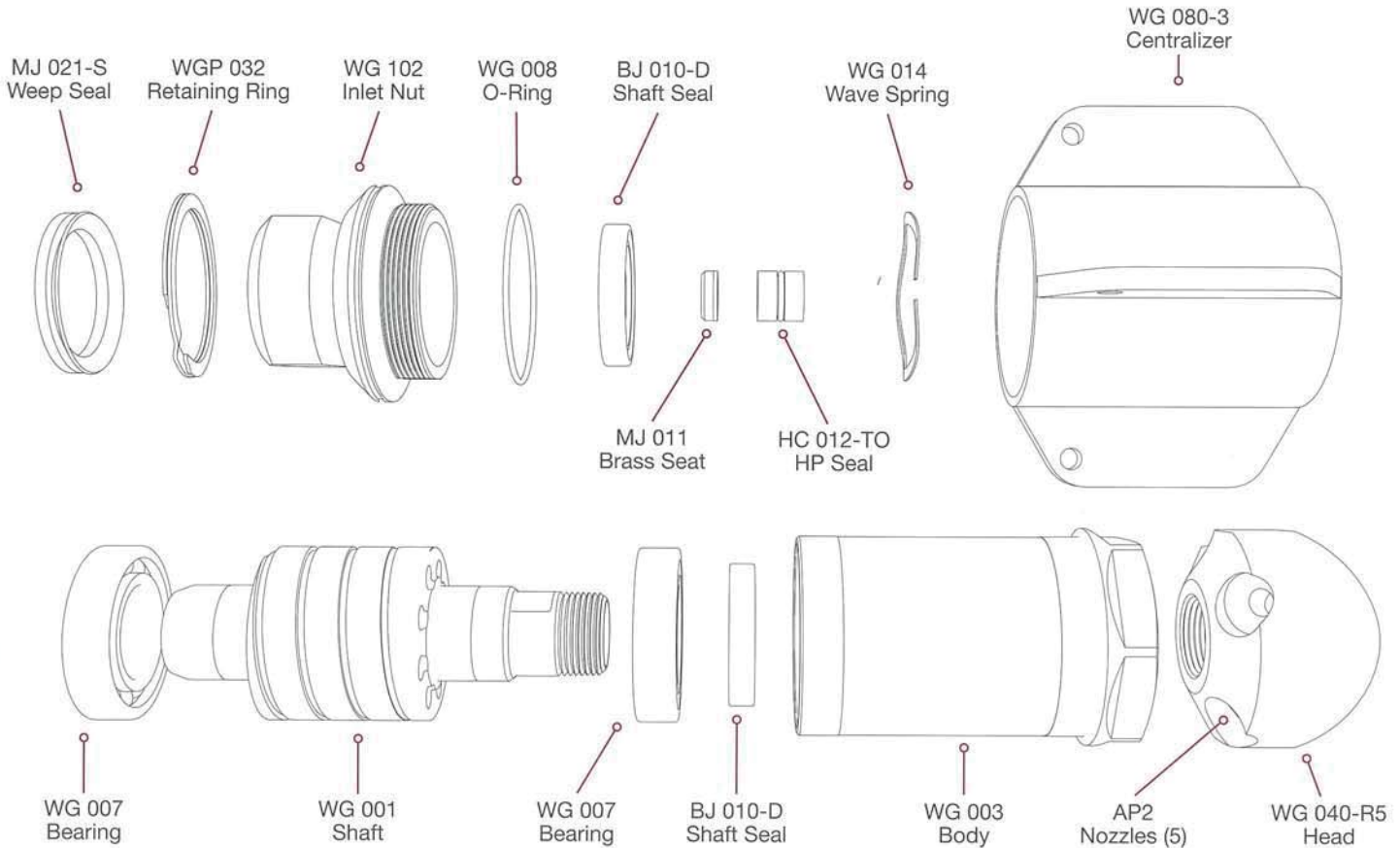

### Maintenance & Overhaul Kits

#### WG 600 • SERVICE KIT

- (1) **BJ 048-F** Visc. Fluid, 6oz.
- (1) **BJ 062-S** Antiseize, 2g
- (1) **GP 025-P2SS** Hex Socket Plug
- (1) **MJ 011** Brass Seat
- (1) **HC 012-TO** HP Seal & O-Ring

#### WG 610 • OVERHAUL KIT

- (2) **BJ 010-D** Shaft Seals
- (1) **BJ 048-F** Visc. Fluid, 6oz.
- (1) **BJ 062-S** Antiseize, 2g
- (1) **MJ 011** Brass Seat
- (1) **HC 012-TO** HP Seal & O-Ring
- (2) **WG 007** Ball Bearings
- (1) **WG 008** O-Ring
- (1) **WG 014** Wave Spring
- (1) **MJ 021-S** Weep Seal
- (1) **WGP 032** Retaining Ring

#### WG 612 • TOOL KIT

- (1) **HC 064** Fill Tube
- (1) **BJ 105** Tool

#### WG 602 • SEAL KIT

- (1) **MJ 011** Brass Seat
- (1) **HC 012-TO** HP Seal & O-Ring

# 8"-36" LINES



**OPERATING WATERBLASTING EQUIPMENT  
CAN BE POTENTIALLY HAZARDOUS.  
SEE PAGE 37 FOR IMPORTANT SAFETY INFORMATION.**

**THE WGP-1 IS EXCELLENT  
FOR LONGER LINES AND  
MODERATE INCLINES.**

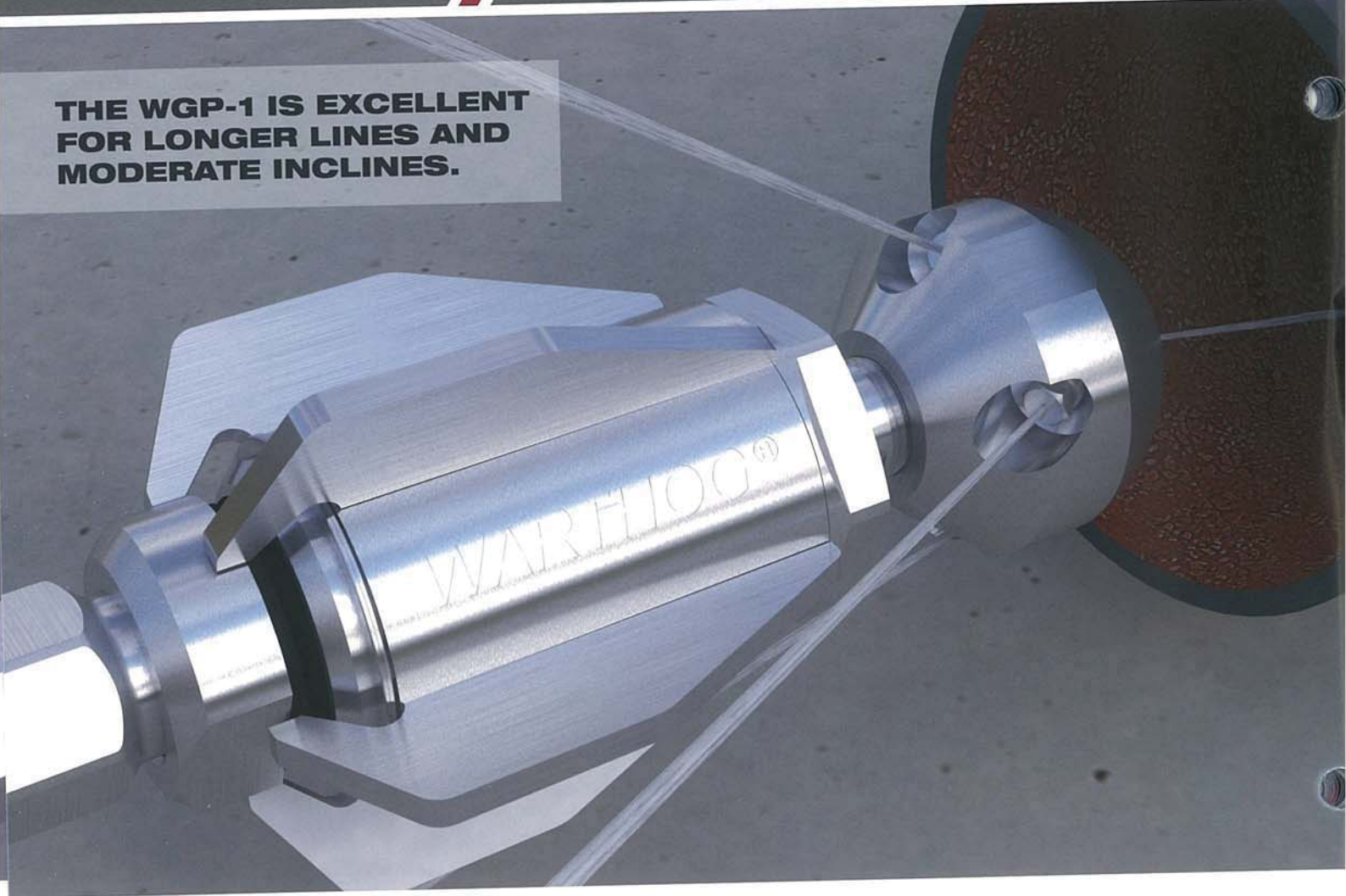

## WGP-1 CLASSIC

8"-36" (203-914 mm) Lines

Our WGP-1 is designed to produce up to 40% more pulling power\* than our WG-1. The rear facing jets are angled more sharply and the centralizer fins have been streamlined. The result is more pulling power to navigate longer lines and moderate inclines, plus makes retrieval of the tool easier.

8"-36" Lines (152-457 mm)	<b>WGP-1 CLASSIC</b>	Up to 5k psi (350 bar)
		50-80 gpm Flows (190-300 l/min)
		Up to 40% More Pulling Power*

### WGP-1 Specifications

<b>MAXIMUM PRESSURE</b>	5k psi	350 bar
<b>OPERATING PRESSURE</b>	1500-5k psi	100-350 bar
<b>ROTATION SPEED</b>	150-300 rpm	
<b>FLOW</b>	50-80 gpm	190-300 l/min
<b>FLOW RATING</b>	4.6 Cv	
<b>PULLING FORCE</b>	100-140 lb	450-623 N
<b>INLET CONNECTION</b>	1 NPT or BSPP	
<b>LENGTH</b>	9.1 in.	231 mm
<b>DIAMETER WITH CENT.</b>	4.8 in.	122 mm
<b>PORTS</b>	5 x 1/8 NPT	
<b>WEIGHT COMPLETE</b>	10.9 lb	4.9 kg

\* With the front jet plugged.

Optional Descaling Head for the WGP-1

**WGP 040-R8-DS**

**TECH TIP: WE RECOMMEND  
PLUGGING THE FRONT JET TO HELP  
MAXIMIZE DESCALING AND PULLING  
POWER WHEN USING THIS OPTION.**

JETTING CHARTS FOR CUSTOMIZING SEWER TOOLS ARE AVAILABLE BY VISITING [www.warthogtools.com](http://www.warthogtools.com) OR GIVE US A CALL AT 1-970-259-2869

## WGP-1 CLASSIC

Exploded View - Part Names and Numbers

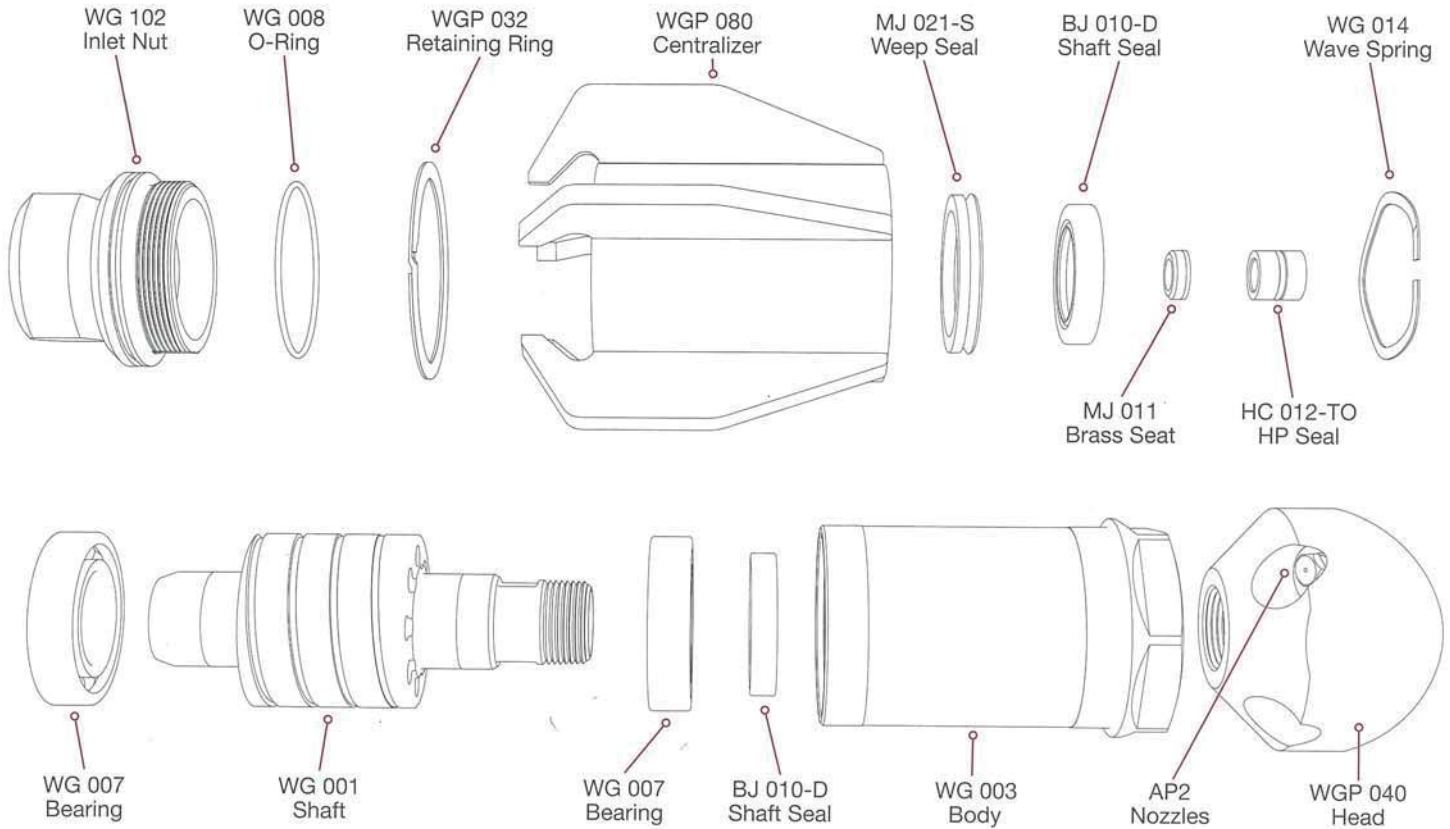

### Maintenance & Overhaul Kits

#### WG 600 • SERVICE KIT

- (1) **BJ 048-F** Visc. Fluid, 6oz.
- (1) **BJ 062-S** Antiseize, 2g
- (1) **GP 025-P2** Hex Socket Plug
- (1) **MJ 011** Brass Seat
- (1) **HC 012-TO** HP Seal & O-Ring

#### WG 610 • OVERHAUL KIT

- (2) **BJ 010-D** Shaft Seals
- (1) **BJ 048-F** Visc. Fluid, 6oz.
- (1) **BJ 062-S** Antiseize, 2g
- (1) **MJ 011** Brass Seat
- (1) **HC 012-TO** HP Seal & O-Ring
- (2) **WG 007** Ball Bearings
- (1) **WG 008** O-Ring
- (1) **WG 014** Wave Spring
- (1) **MJ 021-S** Weep Seal
- (1) **WGP 032** Retaining Ring

#### WG 612 • TOOL KIT

- (1) **HC 064** Fill Tube
- (1) **BJ 105** Tool

#### WG 602 • SEAL KIT

- (1) **MJ 011** Brass Seat
- (1) **HC 012-TO** HP Seal & O-Ring



**WD 1-1/4 WITH TWO EXTRA  
NOZZLE PORTS AND HIGH  
FLOW CAPACITY.**



## WD 1-1/4 CLASSIC

High-flow For 8"-36" (152-457 mm) Lines

The WD 1-1/4 is designed to handle the same applications as the WG-1 but at higher flows. The 1-1/4" inlet combined with seven ports effectively distribute more water.

Descaling heads are not available for this model.

<b>WD 1-1/4 CLASSIC</b>	Up to 5k psi (350 bar)
	80-120 gpm Flows (300-450 l/min)
	8"-36" Lines (152-457 mm)
	High Flow Model

### WD 1-1/4 Classic Specifications

<b>MAXIMUM PRESSURE</b>	5k psi	350 bar
<b>OPERATING PRESSURE</b>	1500-5k psi	100-350 bar
<b>ROTATION SPEED</b>	150-300 rpm	
<b>FLOW</b>	80-120 gpm	300-450 l/min
<b>FLOW RATING</b>	7.6 Cv	
<b>PULLING FORCE</b>	130-190 lb	600-850 Nm
<b>INLET CONNECTION</b>	1-1/4 NPT or BSPP	
<b>LENGTH</b>	9.1 in.	231 mm
<b>DIAMETER WITH CENT.</b>	4.8 in.	122 mm
<b>NOZZLE PORTS</b>	7 x 1/8 NPT	
<b>WEIGHT COMPLETE</b>	11 lb	5.0 kg



# WD 1-1/4 CLASSIC

Exploded View - Part Names and Numbers

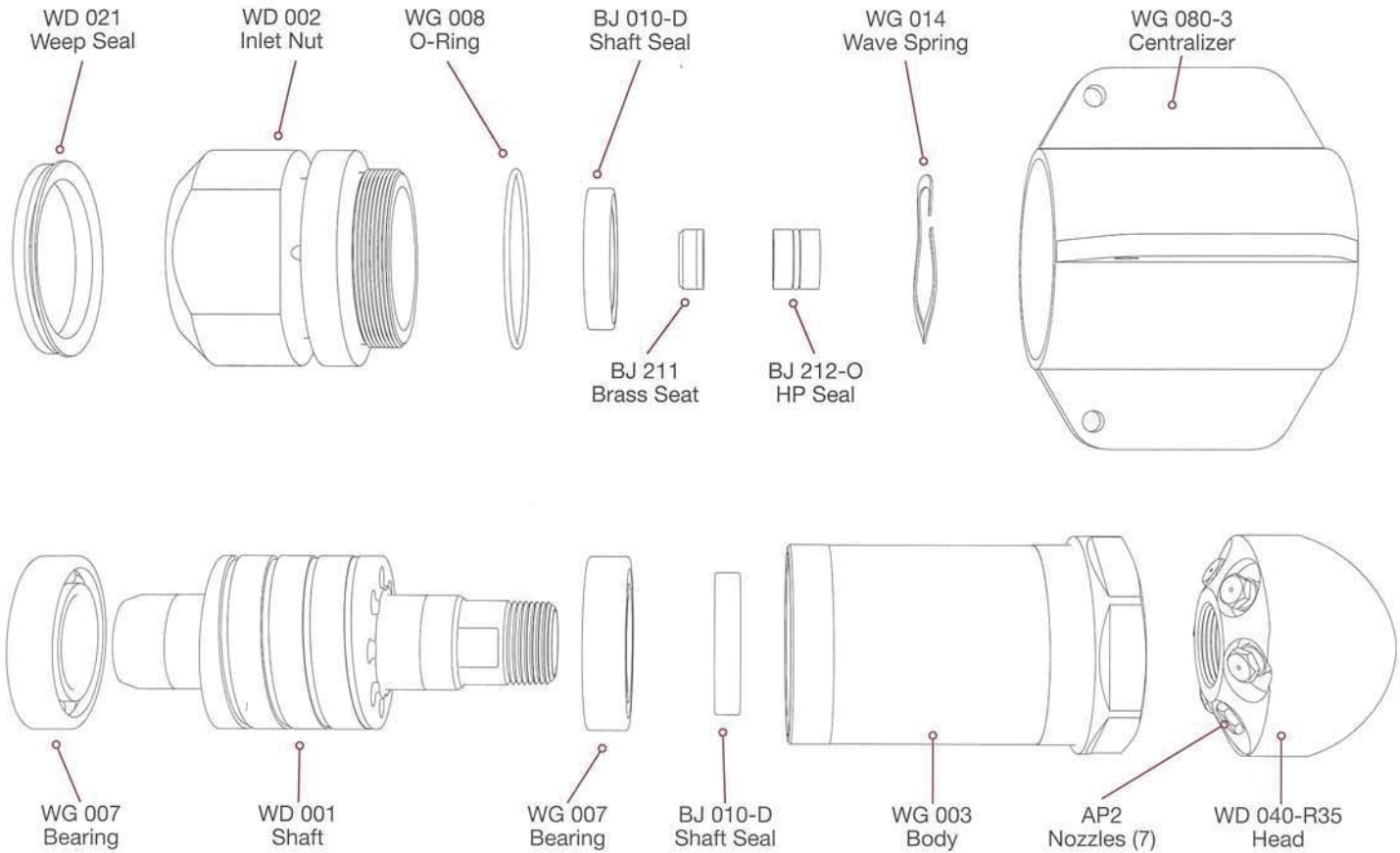

## Maintenance & Overhaul Kits

### WD 600 • SERVICE KIT

- (1) **BJ 048-F** Visc. Fluid, 6oz.
- (1) **BJ 062-S** Antiseize, 2g
- (1) **GP 025-P2SS** Hex Socket Plug
- (1) **BJ 211** Brass Seat
- (1) **BJ 212-O** HP Seal & O-Ring

### WD 602 • SEAL KIT

- (1) **BJ 211** Brass Seat
- (1) **BJ 012-O** HP Seal & O-Ring

### WD 610 • OVERHAUL KIT

- (1) **BJ 048-F** Visc. Fluid, 6oz.
- (2) **BJ 010-D** Shaft Seals
- (1) **BJ 062-S** Antiseize, 2g
- (1) **BJ 211** Brass Seat
- (1) **BJ 012-O** HP Seal & O-Ring
- (2) **WG 007** Ball Bearings
- (1) **WD 021** Seal
- (1) **WG 008** O-Ring
- (1) **WG 014** Wave Spring

### WG 612 • TOOL KIT

- (1) **HC 064** Fill Tube
- (1) **BJ 105** Tool



**NEW!**

**SAFELY ACCESS BURIED  
UTILITIES WITH HIGH  
PRESSURE WATER.**

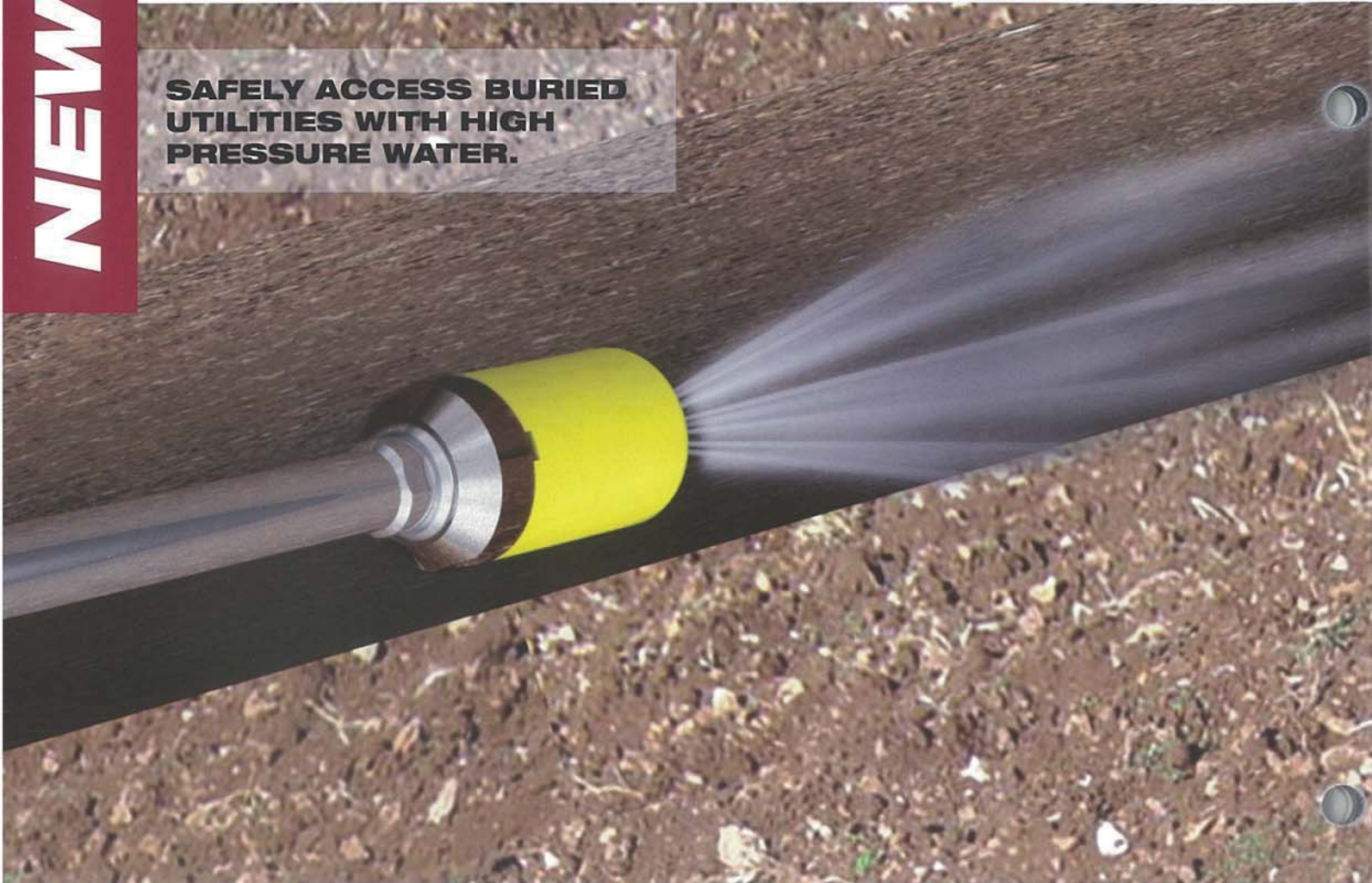

## ROTARY HYDRO-X

### Rotary Hydro Excavation Tools

Hydro Excavation is a safe alternative to access buried utilities by potholing or trenching with high pressure water.

**Three options available for different applications:**

- **HXR 610-10: Higher flow for harder surfaces**
- **HXR 610-8: Intermediate flow for general use**
- **HXR 610-5: Lower flow for water savings**

**FEATURES:**

- Angled rotating jet pattern reduces undercutting and safely cleans around utilities
- Carbide seat for long nozzle life
- Fully rebuildable tool
  - o Inexpensive rebuild kits reduce cost of ownership by extending the life of the tool with minimal maintenance
  - o Replaceable shield cap

### **HXR-300**

Up to 5k psi (350 bar)
3-15 gpm Flows (9-58 l/min)
3 Flow Ranges Available

### Rotary Hydro-X Specifications

<b>PRESSURE RANGE</b>	Up to 5k psi 340 bar
<b>FLOW RANGE</b>	Up to 15 gpm 9-58 l/min
<b>CONE SPRAY ANGLE</b>	18°
<b>INLET CONNECTION</b>	0.5-14 NPT
<b>WEIGHT</b>	1.1 lb 0.5 kg
<b>DIAMETER</b>	1.75 in. 44 mm
<b>LENGTH</b>	4.2 in. 107 mm

## HXR-300 NOW AVAILABLE ROTARY HYDRO EXCAVATION TOOLS



**REPLACEABLE SHIELD CAP**  
Made from durable, impact resistant UHMW

**ANGLED ROTATING JET PATTERN**  
Outstanding jet quality minimizes undercutting and safely removes material around utilities

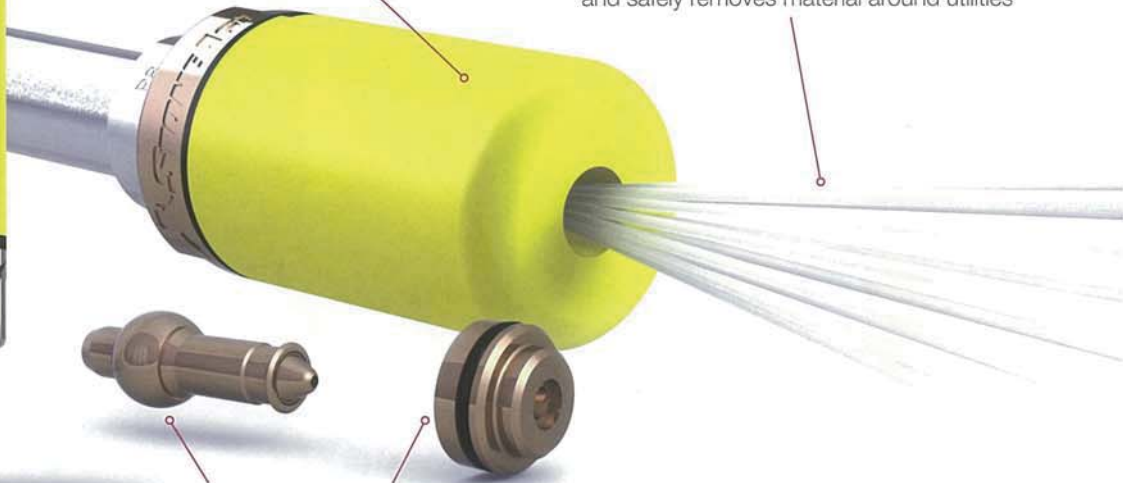

**REPLACEABLE COMPONENTS MADE FROM LONG LIFE CARBIDE STEEL**  
Allows the HXR-300 to be serviced quickly and inexpensively

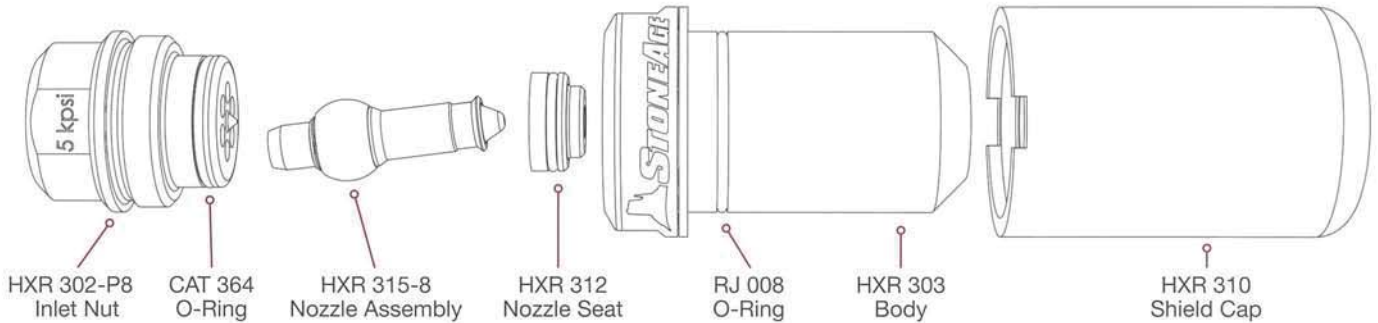

### Maintenance & Overhaul Kits

#### INTERNAL PARTS

##### HXR 610-10 • SERVICE KIT

- (1) CAT 364 O-Ring
- (1) HXR 306-10 ID Ring, White
- (1) HXR 312 Nozzle, Seat
- (1) HXR 315-10 Nozzle, Stem

##### HXR 610-8 • SERVICE KIT

- (1) CAT 364 O-Ring
- (1) HXR 306-8 ID Ring, Black
- (1) HXR 312 Nozzle, Seat
- (1) HXR 315-8 Nozzle, Stem

##### HXR 610-5 • SERVICE KIT

- (1) CAT 364 O-Ring
- (1) HXR 306-5 ID Ring, Purple
- (1) HXR 312 Nozzle, Seat
- (1) HXR 315-5 Nozzle, Stem

#### EXTERNAL PARTS

##### HXR 615-10 • SERVICE KIT

- (1) HXR 310 Shield, Yellow
- (1) HXR 306-10 ID Ring, White
- (1) RJ 008 O-Ring

##### HXR 615-8 • SERVICE KIT

- (1) HXR 310 Shield, Yellow
- (1) HXR 306-8 ID Ring, Black
- (1) RJ 008 O-Ring

##### HXR 615-5 • SERVICE KIT

- (1) HXR 310 Shield, Yellow
- (1) HXR 306-5 ID Ring, White
- (1) RJ 008 O-Ring

**SINGLE, DOUBLE OR TRIPLE  
JETS – FOR PRECISE &  
ACCURATE SOIL REMOVAL**



**HX-101**  
Single Head Assembly  
• OC1H Carbide (1)



**HX-102**  
Double Head Assembly  
• AP2 Attack Tips (2)



**HX-103S**  
Triple Head Assembly  
• AP2 Attack Tips (3)

## NON-ROTARY HYDRO-X

### Static Hydro Excavation Tools

Utilizes replaceable 1/8" npt AP2 Attack Tip nozzles (HX-102/103 models) or a single OC1H 1/4" npt carbide nozzle (HX-101). Using a single nozzle channels all of your pumps power in one direction for the most digging power. Whereas the in-line 2 and 3 patterns give operators the ability to jet with a wider spray pattern to trench material faster.

Each head has a 1/2" npt inlet connection to attach to the operating wand.

The included high-visibility urethane guard is replaceable with three bolts.

### HYDRO-X

Up to 5k psi (350 bar)

3–12 gpm Flows (9–58 l/min)

3 Jet Patterns Available

### Rotary Hydro-X Specifications

<b>PRESSURE RANGE</b>	Up to 5k psi 340 bar
<b>FLOW RANGE</b>	Up to 15 gpm 58 l/min
<b>CONE SPRAY ANGLE</b>	18°
<b>INLET CONNECTION</b>	0.5-14 NPT
<b>WEIGHT</b>	1.1 lb 0.5 kg
<b>DIAMETER</b>	1.75 in. 44 mm
<b>LENGTH</b>	4.2 in. 107 mm

Maximize the cleaning effectiveness of Warthog sewer nozzles.  
Ask your Account Representatives about configuration options and extensions.



## 6 OR 8-WHEEL ADJUSTABLE CENTRALIZERS

### **WG 286-M-P16 - STRAIGHT PIPES**

*13"-36" diameters (330-915 mm)*

### **WG 288-S-P16 - PIPES W/BENDS**

*16.5"-22" diameters (420-560 mm)*



## POLY-FIN CENTRALIZERS

### **WG 070**

*Available in 6", 8", 10" & 12" interchangeable skid sizes.  
(152 mm, 203 mm, 254 mm & 305 mm)*



## SUPER CENTRALIZERS

### **WS 085 - 4.5" DIAMETER**

*For 5" (127 mm) minimum pipe ID*

### **WH 085 - 5.5" DIAMETER**

*For 6" (152 mm) minimum pipe ID*

### **WG-085 - 7" DIAMETER**

*For 8" (203 mm) minimum pipe ID*



## MANHOLE CLEANERS

Turn your Warthog pipe cleaning tool into an effective Manhole Cleaner

The benefit of using this design is that the jets are directed at the manhole walls at all times which makes it much more effective and safer than 3D tools. The conversion is simple and requires exchanging the standard WG 040 head with our Manhole Cleaner head kits. The head conversion kits include a head with 1/2" extension arms and nozzles. Call our Customer Service team for kit options. We recommend the use of manhole cover plates for increased safety.

**1. Acceptance of Terms and Conditions.** Receipt of these Terms and Conditions of Sale ("Terms and Conditions") shall operate as the acceptance by StoneAge, Inc. ("Seller") of the order submitted by the purchaser ("Buyer"). Such acceptance is made expressly conditional on assent by Buyer to these Terms and Conditions. Such assent shall be deemed to have been given unless written notice of objection to any of these Terms and Conditions (including inconsistencies between Buyer's purchase order and this acceptance) is given by Buyer to Seller promptly on receipt hereof.

Seller desires to provide Buyer with prompt and efficient service. However, to individually negotiate the terms of each sales contract would substantially impair Seller's ability to provide such service. Accordingly, the product(s) furnished by Seller are sold only according to the terms and conditions stated herein and with the terms and conditions stated in any effective StoneAge Dealer Agreement or StoneAge Reseller Agreement, if applicable. Notwithstanding any terms and conditions on Buyer's order, Seller's performance of any contract is expressly made conditional on Buyer's agreement to these Terms and Conditions unless otherwise specifically agreed to in writing by Seller. In the absence of such agreement, commencement of performance, shipment and/or delivery shall be for Buyer's convenience only and shall not be deemed or construed to be an acceptance of Buyer's terms and conditions.

**2. Payment/Prices.** Unless other arrangements have been made in writing between Seller and Buyer, payment for the product(s) shall be made upon receipt of invoice. The prices shown on the face hereof are those currently in effect. Prices invoiced shall be per pricelist in effect at the time of shipment. Prices are subject to increase for inclusion of any and all taxes which are applicable and which arise from the sale, delivery or use of the product(s), and the collection of which Seller is or may be responsible to provide to any governmental authority, unless acceptable exemption certificates are provided by Buyer in accordance with applicable law. Buyer shall pay all charges for transportation and delivery and all excise, order, occupation, use or similar taxes, duties, levies, charges or surcharges applicable to the product(s) being purchased, whether now in effect or hereafter imposed by any governmental authority, foreign or domestic.

**3. Warranty.** SELLER MAKES NO WARRANTIES OR REPRESENTATIONS AS TO THE PERFORMANCE OF ANY PRODUCT EXCEPT AS SET FORTH IN THE STONEAGE LIMITED WARRANTY PROVIDED WITH THE PRODUCT.

**4. Delivery.** Seller is not obligated to make delivery by a specified date, but will always use its best efforts to make delivery within the time requested. The proposed shipment date is an estimate. Seller will notify Buyer promptly of any material delay and will specify the revised delivery date as soon as practicable. UNDER NO CIRCUMSTANCES SHALL SELLER HAVE ANY LIABILITY WHATSOEVER FOR LOSS OF USE OR FOR ANY DIRECT OR CONSEQUENTIAL DAMAGES RESULTING FROM DELAY REGARDLESS OF THE REASON(S).

All product(s) will be shipped F.O.B. point of origin, unless specifically agreed otherwise, and Buyer shall pay all shipping costs and insurance costs from that point. Seller, in its sole discretion, will determine and arrange the means and manner of transportation of the product(s). Buyer shall bear all risk of loss commencing with the shipment or distribution of the product(s) from Seller's warehouse. Order shortages or errors must be reported within fifteen (15) business days from receipt of shipment to secure adjustment. No product(s) may be returned without securing written approval from Seller.

**5. Modification.** These Terms and Conditions are intended by Seller and Buyer to constitute a final, complete and exclusive expression of agreement relating to the subject matter hereof and cannot be supplemented or amended without Seller's prior written approval.

**6. Omission.** Seller's waiver of any breach or Seller's failure to enforce any of these Terms and Conditions at any time, shall not in any way affect, limit or waive Seller's right thereafter to enforce and compel strict compliance with every term and condition hereof.

**7. Severability.** If any provision of these Terms and Conditions is held to be invalid or unenforceable, such invalidity or unenforceability shall not affect the validity or enforceability of the other portions hereof.

**8. Disputes.** Seller and Buyer shall attempt in good faith to promptly resolve any dispute arising under these Terms and Conditions by negotiations between representatives who have authority to settle the controversy. If unsuccessful, Seller and Buyer shall further attempt in good faith to settle the dispute by nonbinding third-party mediation, with fees and expenses of such mediation apportioned equally to each side. Any dispute not so resolved by negotiation or mediation may then be submitted to a court of competent jurisdiction in accordance with the terms hereof. These procedures are the exclusive procedures for the resolution of all such disputes between the Seller and Buyer.

**9. Governing Law.** All sales, agreements for sale, offers to sell, proposals, acknowledgments and contracts of sale, including, but not limited to, purchase orders accepted by Seller, shall be considered a contract under the laws of the State of Colorado and the rights and duties of all persons, and the construction and effect of all provisions hereof shall be governed by and construed according to the laws of such state.

**10. Jurisdiction and Venue.** Seller and Buyer agree that the state or federal courts located within the City and County of Denver, Colorado shall have sole and exclusive jurisdiction over any litigation concerning any dispute arising under these Terms and Conditions not otherwise resolved pursuant to Section 9 as well as any alleged defects of any Products or damages sustained as a result of such alleged defects. Seller and Buyer further agree that should any litigation be commenced in connection with such a dispute, it shall only be commenced in such courts. Seller and Buyer agree to the exclusive jurisdiction of such courts and neither will raise any objection to the jurisdiction and venue of such courts, including as a result of inconvenience.

**11. Attorney's Fees.** If any litigation is commenced between Seller and Buyer, or their personal representatives, concerning any provision hereof, the party prevailing in the litigation shall be entitled, in addition to such other relief that is granted, to a reasonable sum as and for their attorneys' fees and costs in such litigation or mediation.

#### STONEAGE TRADEMARK LIST

View the list of StoneAge's trademarks and service marks and learn how the trademarks should be used. Use of StoneAge trademarks may be prohibited, unless expressly authorized.

<http://www.StoneAgetools.com/trademark-list/>

#### STONEAGE PATENT DATA

View the list of StoneAge's current U.S. patent numbers and descriptions.

<http://www.sapatents.com>

#### STONEAGE TERMS AND WARRANTY

View StoneAge's Terms and Warranty Conditions online.

<http://www.stoneagetools.com/terms>

<http://www.stoneagetools.com/warranty>

Warranties set forth herein extend only to End-Users, meaning customers acquiring, or that have previously acquired, a product manufactured by StoneAge ("Product") for their own use and not for resale, either directly from StoneAge Inc. ("StoneAge") or from a StoneAge Authorized Dealer or Reseller ("Dealer"). No warranty of any kind or nature is made by StoneAge beyond those expressly stated herein.

**1. LIMITED WARRANTY PERIOD.** Subject to the limitations and conditions hereinafter set forth, StoneAge warrants its Product to be free from defects in workmanship and material for a period of one (1) year from the date of purchase by the End-User, provided that the end of the limited warranty period shall not be later than eighteen (18) months from the date of shipment of the Product to the Dealer or the End-User by StoneAge ("Limited Warranty Period"). All replacement parts which are furnished under this Limited Warranty and properly installed shall be warranted to the same extent as the original Product under this Limited Warranty if, and only if, the original parts were found to be defective within the original Limited Warranty Period covering the original Product. Replacement parts are warranted for the remainder of the original Limited Warranty Period. This Limited Warranty does not cover any component part of any Product not manufactured by StoneAge. Any such component part is subject exclusively to the component manufacturer's warranty terms and conditions.

**2. LIMITED WARRANTY COVERAGE.** StoneAge's sole obligation under this Limited Warranty shall be, at StoneAge's option and upon StoneAge's inspection, to repair, replace or issue a credit for any Product which is determined by StoneAge to be defective in material or workmanship. StoneAge reserves the right to examine the alleged defective Product to determine whether this Limited Warranty is applicable, and final determination of limited warranty coverage lies solely with StoneAge. No statement or recommendation made by a StoneAge representative, Dealer or agent to End-User shall constitute a warranty by StoneAge or a waiver or modification to any of the provisions hereof or create any liability for StoneAge.

**3. WARRANTY SERVICE PROVIDERS.** Service and repair of the Product is to be performed only by StoneAge authorized service representatives, including Dealers who are authorized repair centers, with StoneAge approved parts. Information about StoneAge authorized service representatives can be obtained through the StoneAge website at [www.stoneagetools.com/service](http://www.stoneagetools.com/service). Unauthorized service, repair or modification of the Product or use of parts not approved by StoneAge will void this Limited Warranty. StoneAge reserves the right to change or improve the material and design of the Product at any time without notice to End-User, and StoneAge is not obligated to make the same improvements during warranty service to any Product previously manufactured.

**4. WARRANTY EXCLUSIONS.** This Limited Warranty does not cover, and StoneAge shall not be responsible for the following, or damage caused by the following: (1) any Product that has been altered or modified in any way not approved by StoneAge in advance in writing; (2) any Product that has been operated under more severe conditions or beyond the rated capacity specified for that Product; (3) depreciation or damage caused by normal wear and tear, failure to follow operation or installation instructions, misuse, negligence or lack of proper protection during storage; (4) exposure to fire, moisture, water intrusion, electrical stress, insects, explosions, extraordinary weather and/or environmental conditions including, but not limited to lightning, natural disasters, storms, windstorms, hail, earthquakes, acts of God or any other force majeure event; (5) damage to any Product caused by any attempt to repair, replace, or service the Product by persons other than StoneAge authorized service representatives; (6) costs of normal maintenance parts and services; (7) damage sustained during unloading, shipment or transit of the Product; or (8) failure to perform the recommended periodic maintenance procedures listed in the Operator's Manual accompanying the Product.

**5. REQUIRED WARRANTY PROCEDURES.** To be eligible for warranty service, the End-User must: (1) report the Product defect to the entity where the Product was purchased (i.e. StoneAge or the Dealer) within the Limited Warranty Period specified in this Limited Warranty; (2) submit the original invoice to establish ownership and date of purchase; and (3) make the Product available to a

StoneAge authorized service representative for inspection to determine eligibility for coverage under this Limited Warranty. This Limited Warranty shall not extend to any person or entity who fails to provide proof of original purchase from StoneAge or a Dealer. No Product may be returned for credit or adjustment without prior written permission from StoneAge.

**6. DISCLAIMER OF IMPLIED WARRANTIES AND OTHER REMEDIES.** EXCEPT AS EXPRESSLY STATED HEREIN (AND TO THE FULLEST EXTENT ALLOWED UNDER APPLICABLE LAW), STONEAGE HEREBY DISCLAIMS ALL OTHER WARRANTIES, EXPRESS OR IMPLIED, INCLUDING WITHOUT LIMITATION ALL IMPLIED WARRANTIES OF MERCHANTABILITY OR FITNESS FOR A PARTICULAR PURPOSE, AND ANY AND ALL WARRANTIES, REPRESENTATIONS OR PROMISES AS TO THE QUALITY, PERFORMANCE OR FREEDOM FROM DEFECT OF THE PRODUCT COVERED BY THIS LIMITED WARRANTY. STONEAGE FURTHER DISCLAIMS ALL IMPLIED INDEMNITIES.

**7. LIMITATION OF LIABILITY.** End-User specifically acknowledges that the Product may be operated at high speeds and/or pressures, and that as such it may be inherently dangerous if not used correctly. End-User shall familiarize itself with all operation materials provided by StoneAge and shall at all times use and require its agents, employees and contractors to use all necessary and appropriate safety devices, guards and proper safe operating procedures. In no event shall StoneAge be responsible for any injuries to persons or property caused directly or indirectly by the operation of the Product if End-User or any agent, employee, or contractor of End-User: (1) fails to use all necessary and appropriate safety devices, guards and proper safe operating procedures; (2) fails to maintain in good working order such safety devices and guards; (3) alters or modifies the Product in any way not approved by StoneAge in advance in writing; (4) allows the Product to be operated under more severe conditions or beyond the rated capacity specified for the Product; or (5) otherwise negligently operates the Product. End-User shall indemnify and hold StoneAge harmless from any and all liability or obligation incurred by or against StoneAge, including costs and attorneys' fees, to or by any person so injured.

TO THE FULL EXTENT ALLOWED BY APPLICABLE LAW, STONEAGE SHALL NOT BE LIABLE FOR ANY INDIRECT, SPECIAL, INCIDENTAL, CONSEQUENTIAL, OR PUNITIVE DAMAGES (INCLUDING WITHOUT LIMITATION, LOSS OF PROFITS, LOSS OF GOODWILL, DIMINUTION OF VALUE, WORK STOPPAGE, INTERRUPTION OF BUSINESS, RENTAL OF SUBSTITUTE PRODUCT, OR OTHER COMMERCIAL LOSS EVEN TO THE EXTENT SUCH DAMAGES WOULD CONSTITUTE DIRECT DAMAGES), WITH RESPECT TO THE COVERED STONEAGE PRODUCT, OR OTHERWISE IN CONNECTION WITH THIS LIMITED WARRANTY, REGARDLESS OF WHETHER STONEAGE HAS BEEN ADVISED OF THE POSSIBILITY OF SUCH DAMAGES.

IT IS UNDERSTOOD THAT STONEAGE'S LIABILITY, WHETHER IN CONTRACT, IN TORT, UNDER ANY WARRANTY, IN NEGLIGENCE, OR OTHERWISE SHALL NOT EXCEED THE AMOUNT OF THE PURCHASE PRICE PAID BY THE END-USER FOR THE PRODUCT. STONEAGE'S MAXIMUM LIABILITY SHALL NOT EXCEED, AND END-USER'S REMEDY IS LIMITED TO EITHER (1) REPAIR OR REPLACEMENT OF THE DEFECTIVE WORKMANSHIP OR MATERIAL OR, AT STONEAGE'S OPTION, (2) REFUND OF THE PURCHASE PRICE, OR (3) ISSUANCE OF A CREDIT FOR THE PURCHASE PRICE, AND SUCH REMEDIES SHALL BE END-USER'S ENTIRE AND EXCLUSIVE REMEDY.

YOU, THE END-USER, UNDERSTAND AND EXPRESSLY AGREE THAT THE FOREGOING LIMITATIONS ON LIABILITY ARE PART OF THE CONSIDERATION IN THE PRICE OF THE STONEAGE PRODUCT YOU PURCHASED.

Some jurisdictions do not allow the limitation or exclusion of liability for certain damages, so the above limitations and exclusions may not apply to you. This Limited Warranty gives you specific legal rights, and you may also have other rights which vary from jurisdiction to jurisdiction. If any provisions of this Limited Warranty is held to be invalid or unenforceable, such invalidity or unenforceability shall not affect the validity or enforceability of the other portions hereof.

**GapVax<sup>®</sup>**

**SECTION A:  
BLOWERS & TRANSFER CASES/  
WATER, VANE & SLUDGE PUMPS**



# BLOWERS

## HIBON:

VTB810	28"	860 CFM TRI-LOBE
VTB820	28"	1400 CFM TRI-LOBE
VTB822	28"	2650 CFM TRI-LOBE
SIAV840	28"	3800 CFM TRI-LOBE
SIAV8702	28"	5250 CFM TRI-LOBE
SIAV6	28"	840 CFM TWO-LOBE
SIAV25	28"	2100 CFM TWO-LOBE
SIAV50	28"	3200 CFM TWO-LOBE

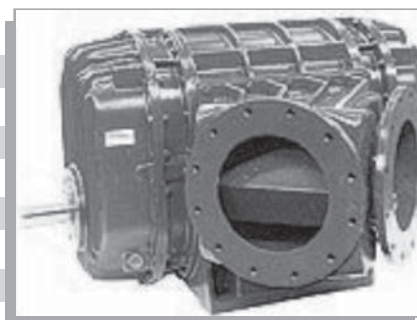

### BRONZE TRI-LOBE:

VTB820B	24"	1400 CFM
---------	-----	----------

### 2000 SERIES:

HH2022	15"	100 CFM
HH2023	15"	150 CFM
HH2031	15"	160 CFM
HH2032	15"	240 CFM
HH2041	15"	250 CFM
HH2042	15"	400 CFM
HH2043	15"	600 CFM
HH2051	15"	390 CFM
HH2052	15"	600 CFM

### 4200 SERIES:

HH4263	15"	2600 CFM
HH4264	15"	3400 CFM
HH4283	15"	4800 CFM
HH4284	15"	6400 CFM

## ROOTS:

406DJV	27"	668 CFM
412DVJ	27"	1332 CFM
616DVJ	27"	2367 CFM
721DVJ	27"	3658 CFM
1016DVJ	27"	4068 CFM
1021DVJ	27"	5184 CFM
1125DVJ	27"	5760 CFM
1024RAS	18"	6000 CFM
824RCS	18"	CFM

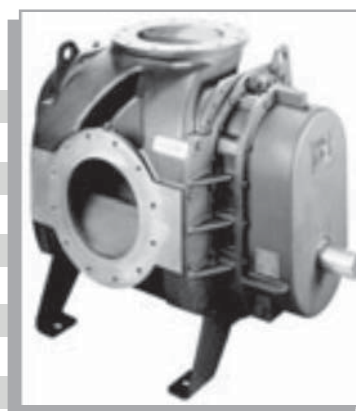

## GARDNER-DENVER:

1021HVQ	28"	5000 CFM
5CDL5	17"	500 CFM
5CDL9	17"	800 CFM
5CDL13	17"	1200 CFM
7CDL11	17"	1600 CFM
7CDL14	17"	2100 CFM
7CDL17	17"	2400 CFM
9CDL13	17"	2400 CFM
9CDL18	17"	3300 CFM
9CDL23	17"	4200 CFM
11CDL23	17"	5000 CFM
11CDL27	17"	5700 CFM
11CDL31	17"	6600 CFM

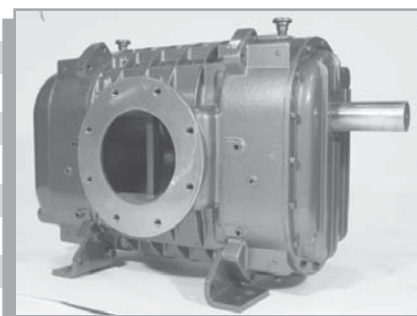

**TRANSFER CASES**

**COTTA:**

TRA011509 (TR2059-40)

**REPLACEMENT PARTS**

TRA011442	UPPER OUTPUT SEAL
GAS006039	LOWER INPUT/OUTPUT SEAL- 1810 SERIES
GAS006043	LOWER INPUT/OUTPUT SEAL- 1760 SERIES
TRA011479	FRONT SHIFT ROD SEAL
TRA011480	REAR SHIFT ROD SEAL
TRA011482	BREATHER CAP

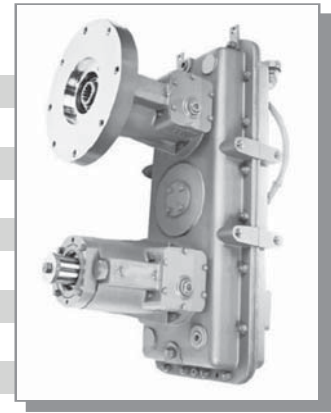

**DANA:**

TRA022309 (792-NLPEPEP-F)

**AIR-SHIFT REPLACEMENT PARTS**

TRA011500	SHIFT ROD R-11
GAS006340	O-RING
GAS006341	O-RING R-20
TRA011501	O-RING R-21
GAS006339	PISTON O-RING R-22
TRA011488	WASHER-SHIFTER ROD R-23
FAS002951	NUT R-24
TRA011502	GASKET R-18
TRA011499	CAP R-25
GAS006332	SHAFT SEAL (29925) REQUIRES 2

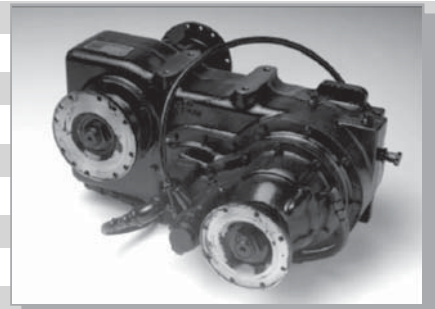

**OMSI:**

DRI022318	1-1.47 RATIO
TRA020000	PVT-PCV/3000 STANDARD TRANSFER CASE
TRA011462	TRANSFER CASE WITH FRONT DISCONNECT

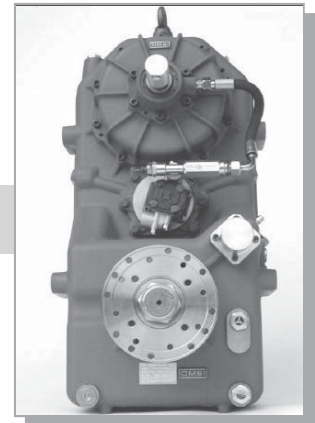

OTHER GEARBOXES AND TRANSFER CASES AVAILABLE

**WATER PUMPS**

**GIANT:**

P223	3.0 GPM@ 3,000 PSI
P319	4.8 GPM@ 3,000 PSI
P316	4.7 GPM@ 3,000 PSI
P54	4.5 GPM@ 4,000 PSI
P58	5.5 GPM@ 3,500 PSI
P450	5.5 GPM@ 5,000 PSI

# WATER PUMPS

## GIANT, CONT'D.:

P420	13.0 GPM@	2,000 PSI
MP4120	8.7 GPM@	3,600 PSI
MP4124	12.6 GPM@	2,500 PSI
MP4130	15.2 GPM@	1,900 PSI
LP123	40.0 GPM@	2,000 PSI
LP200	20.0 GPM@	3,000 PSI
LP301	18.0 GPM@	4,000 PSI
P223	9.0 GPM@	10,000 PSI
P223	10.0 GPM@	10,000 PSI
P223	29.0 GPM@	3,000 PSI
P223	35.0 GPM@	2,200 PSI
P223	66.0 GPM@	23,000 PSI

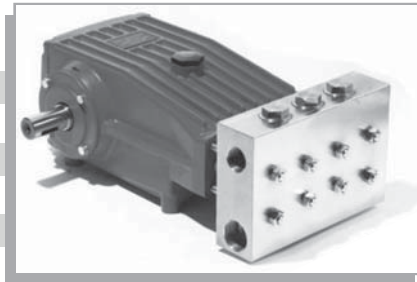

## MYERS:

C25	25.0 GPM@	2,500 PSI
CPM18-40	18.0 GPM@	4,000 PSI
CPM24-30	24.0 GPM@	MAX. PRESSURE: 3,000 PSI
D50-12	50.0 GPM@	1,200 PSI
D60-10	60.0 GPM@	1,000 PSI
D35-12	35.0 GPM@	1,200 PSI
D65-16	65.0 GPM@	2,000 PSI
DP120-12	120.0 GPM@	1,200 PSI
DP90-18	90.0 GPM@	1,800 PSI
DP80-20	80.0 GPM@	2,000 PSI
DP70-22	70.0 GPM@	2,200 PSI
DP55-28	55.0 GPM@	2,800 PSI
DP40-38	40.0 GPM@	3,800 PSI
DP28-55	28.0 GPM@	5,500 PSI
E54-30	54.0 GPM@	3,000 PSI
E70-23	70.0 GPM@	2,300 PSI
E80-20	80.0 GPM@	2,000 PSI
E110-14	110.0 GPM@	1,400 PSI

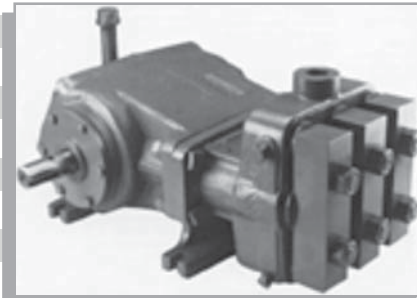

## URACA:

KD627	185.0 GPM@	3,800 PSI
KD708	80.0 GPM@	2,000 PSI*
KD708	40.0 GPM@	3,650 PSI*
KD708-GK	8.0 GPM@	17,500 PSI
KD716	102.0 GPM@	2,030 PSI
KD716	90.0 GPM@	2,500 PSI*
KD724G	125.0 GPM@	3,000 PSI*
KD724G	142.0 GPM@	2,500 PSI
KD725	170.0 GPM@	3,300 PSI
P3-45	125.0 GPM@	2,200 PSI
P3-45	110.0 GPM@	2,500 PSI*

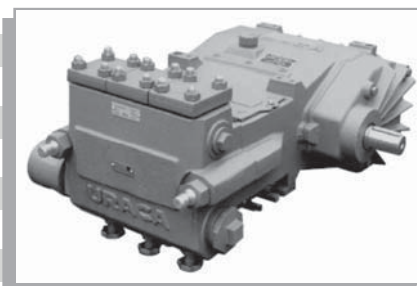

VSV10/300 SAFETY VALVE

MSUV29/300 DIAPHRAGM OPERATED UNLOADING & SAFETY VALVE

\*Replacement Parts In Stock

**VANE PUMPS**

**DEMAG:**

SL15DV	74 CFM
SL20DV	97 CFM
SLS34DV	118 CFM
SLS54DV	191 CFM
RTL60	189 CFM
RTL80	269 CFM
RTL100	300 CFM

**JUROP:**

PNR82	268 CFM
PNR102	332 CFM
PNR122	395 CFM
PNR142	452 CFM

\*OTHERS AVAILABLE UPON REQUEST

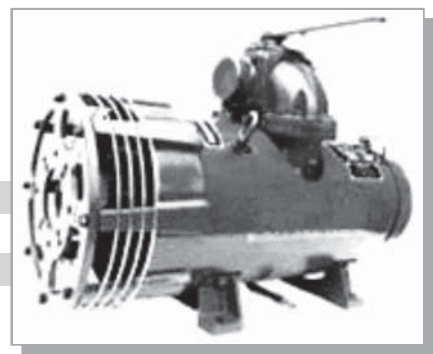

**FRUITLAND:**

RCF250	180 CFM
RCF370	275 CFM
RCF500	350 CFM
RCF1200	645 CFM

**SLUDGE PUMPS**

**STANLEY:**

S4T 4" LESS STRAINER

**REPLACEMENT PARTS**

4002179	LIFTING BRACKET
4002152B	HYDRAULIC MOTOR
4001539	BOLTS (REQUIRES 6)
4002154	O-RING
4002156	UPPER BEARING
4002190A	SHAFT SPLINED
4002155	BEARING HOUSING
4002171	PLUG
4002191	LOWER BEARING
4002159	SNAP RING
4002161	O-RING
4002192	SEAL PLATE
4002181	O-RING
4002194	IMPELLER
4002168	VOLUTE
4002178	STRAINER
4002180	BOLT WITH WASHER (REQUIRES 3)

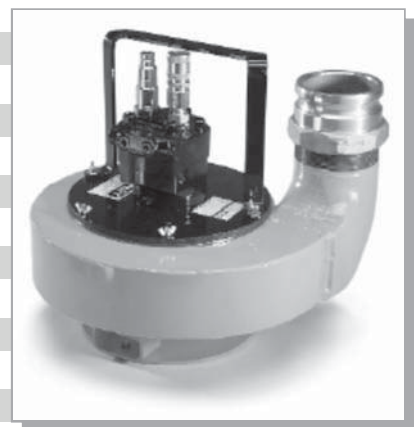

**STANLEY, CONT'D.:**

4002172	LOCKING SCREW
4002193	SHAFT SEAL ASSEMBLY
4002167	GASKET
4002166	DISCHARGE FLANGE
4002165	BOLT WITH WASHER (REQUIRES 2)
4001535	BOLT WITH WASHER (REQUIRES 3 OF EACH)
4002164	HANDLE
4005139	BOLT WITH WASHER (REQUIRES 4)
4002195	O-RING KIT NOT SHOWN

S4T-SC 4" WITH SILICONE CARBIDE SEAL LESS STRAINER

**REPLACEMENT PARTS:** SAME AS S4T EXCEPT REPLACE 4002193 WITH 4002193A

This page left intentionally blank

**GapVax<sup>®</sup>**

**SECTION B:  
SILENCERS/VALVES**

**SILENCERS****INTAKE:**

SI6010523

**DISCHARGE:**

SI6010524

**INTAKE:**

SI6010531

**DISCHARGE:**

SI6010532

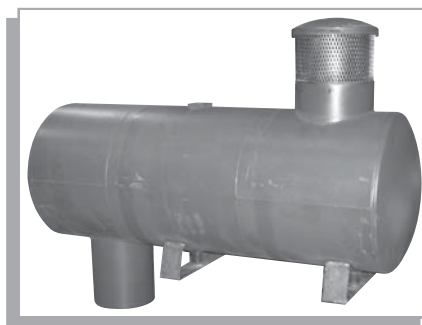
**SILENCER RAINCAP:**

PIP008692

**INTAKE SILENCER SCREEN & HEAD:**

TNK020255

FO10938

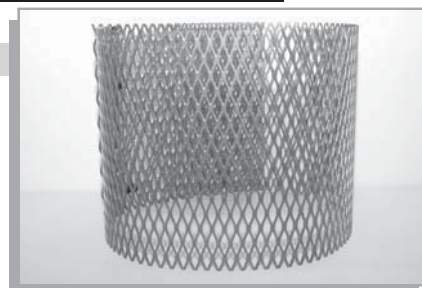
**SAFETY SCREEN:**

AO12589 FINAL FILTER SCREEN

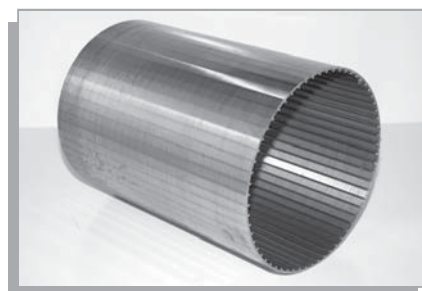
**VALVES****BRASS PISTON VALVE:**

VAL011534 4" FLANGED TO 4" NPT

VAL012007 6" FLANGED TO 6" NPT

VAL011543 4" NPT BOTH SIDES

VAL011544 6" NPT BOTH SIDES

VAL022382 8" NPT BOTH SIDES

VAL012136 4" FLANGED BOTH SIDES

VAL012135 6" FLANGED BOTH SIDES

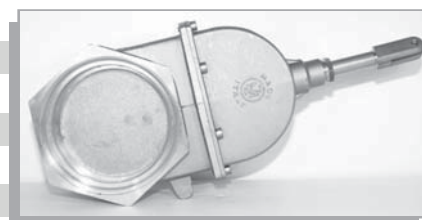



## BRASS PISTON VALVE HANDLE:

VAL011547 4" HANDLE ASSEMBLY  
VAL011548 6" HANDLE ASSEMBLY  
VAL011645 8" HANDLE ASSEMBLY



## BRASS PISTON VALVE HANDLE-NEW STYLE:

VAL011555 FITS 4" & 6" VALVES



## BRASS QUICK-OPENING LEVER VALVE:

VAL011541 2" NPT  
VAL011542 3" NPT  
VAL011630 4" NPT  
VAL011546 6" NPT



## BETTS-STYLE KNIFE VALVE:

VAL012050 3" TTMA FLANGED X FLANGED STEEL  
VAL012051 3" TTMA FLANGED X FLANGED STAINLESS  
VAL012052 4" TTMA FLANGED X FLANGED STEEL  
VAL012053 4" TTMA FLANGED X FLANGED STAINLESS  
VAL012054 6" TTMA FLANGED X FLANGED STEEL  
VAL012055 6" TTMA FLANGED X FLANGED STAINLESS  
VAL012056 3" TTMA FLANGED X MALE THREAD STEEL  
VAL012057 3" TTMA FLANGED X MALE THREAD STAINLESS  
VAL012058 4" TTMA FLANGED X MALE THREAD STEEL  
VAL012059 4" TTMA FLANGED X MALE THREAD STAINLESS  
VAL012060 6" TTMA FLANGED X MALE THREAD STEEL  
VAL012061 6" TTMA FLANGED X MALE THREAD STAINLESS

## BETTS-STYLE KNIFE VALVE/ANSI FLANGE:

VAL012062 3" FLANGED X FLANGED STEEL  
VAL012063 3" FLANGED X FLANGED STAINLESS  
VAL012064 4" FLANGED X FLANGED STEEL  
VAL012065 4" FLANGED X FLANGED STAINLESS  
VAL012066 6" FLANGED X FLANGED STEEL  
VAL012067 6" FLANGED X FLANGED STAINLESS  
VAL012068 3" FLANGED X MALE THREAD STEEL  
VAL012069 3" FLANGED X MALE THREAD STAINLESS  
VAL012070 4" FLANGED X MALE THREAD STEEL  
VAL012071 4" FLANGED X MALE THREAD STAINLESS



**BETTS-STYLE KNIFE VALVE/ANSI FLANGE, CONT'D.**

- VAL012072 6" FLANGED X MALE THREAD STEEL
- VAL012073 6" FLANGED X MALE THREAD STAINLESS

**AIR-ACTUATED BUTTERFLY VALVE:**

- VAL011764 3"
- VAL011766 4"
- VAL011767 5"
- VAL022322 6"
- VAL011772 8"
- VAL011761 10"
- VAL011763 12"

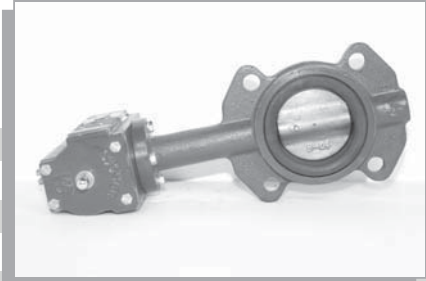

**MANUAL LEVER BUTTERFLY VALVE:**

- VAL011728 3"
- VAL011718 4"
- VAL011719 5"
- VAL011721 6"
- VAL011734 8"
- VAL011722 10"



**BRASS BALL VALVE:**

- VAL011812 3/4"
- VAL011813 1"
- M200-1-1/4 1-1/4"
- M200-1-1/2 1-1/2"
- VAL011815 2"
- VAL011816 3"
- VAL011976 4"



**FLANGED BALL VALVE:**

**USED ON BLOW-OFF SYSTEM**

- VAL011559 6" FLANGED BALL VALVE
- VAL011836 HANDLE FOR 1/4 TO 1/2 VALVE
- VAL020977 HANDLE FOR 3/4 TO 1-1/2 VALVE

**BUTECH VALVE:**

VAL020523	MANUAL
VAL011755	AIR OPERATED
VAL022111	VALVE REBUILD KIT
VAL022366	NEW VALVE/MANUAL
VAL022367	NEW VALVE/AIR OPERATED

**HI-PRESSURE BALL VALVE:**

VAL011916	1/4" WORKING PRESSURE 7350 PSI
VAL011917	3/8" WORKING PRESSURE 7350 PSI
VAL011918	1/2" WORKING PRESSURE 7350 PSI
VAL011919	3/4" WORKING PRESSURE 5880 PSI
VAL011920	1" WORKING PRESSURE 5145 PSI
VAL011921	1-1/4" WORKING PRESSURE 6175 PSI

**HI-PRESSURE 3-WAY BALL VALVE:**

VAL011910	1/4" WORKING PRESSURE 7500 PSI
VAL011911	3/8" WORKING PRESSURE 7500 PSI
VAL011912	1/2" WORKING PRESSURE 5000 PSI
VAL011913	3/4" WORKING PRESSURE 5000 PSI
VAL011914	1" WORKING PRESSURE 5000 PSI
VAL011915	1-1/4" WORKING PRESSURE 5000 PSI

**VACUUM RELIEF VALVE:****3" VACUUM RELIEF VALVES**

14-297-V6	SET @ 6" MERCURY
14-297-V8	SET @ 8" MERCURY
14-297-V10	SET @ 10" MERCURY
14-297-V12	SET @ 12" MERCURY
14-297-V13	SET @ 13" MERCURY
14-297-V14	SET @ 14" MERCURY
14-297-V15	SET @ 15" MERCURY
14-297-V16	SET @ 16" MERCURY
14-297-V18	SET @ 18" MERCURY

**BRASS PRESSURE RELIEF VALVE:**

VAL012129	1-1/4"
VAL011635	1-1/2"
VAL011636	2"

**HYDRAULIC SPOOL VALVE:**

- VAL011583 OLD STYLE POWER BEYOND VALVE 1/2"
- VAL011582 OLD STYLE POWER BEYOND VALVE 3/4"
- VAL011584 SPOOL VALVE FOR WASHDOWN ASSEMBLY
- VAL011580 MOTORIZED AUGER VALVE
- VAL011588 2 SPOOL VALVE
- VAL011590 MOTORIZED 2 SPOOL
- VAL011591 3 SPOOL VALVE
- VAL011592 MOTORIZED 3 SPOOL
- VAL012093 4 SPOOL VALVE

**OTHERS AVAILABLE-CALL FOR PRICING**

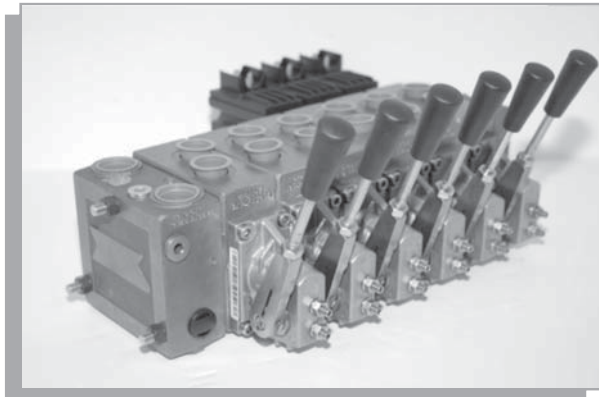

This page left intentionally blank

**GapVax<sup>®</sup>**

**SECTION C:  
HOSES & TUBING/  
FITTINGS & COUPLERS**

**TIGERFLEX-SERIES PF:**

CLEAR POLYURETHANE TRANSFER HOSE WITH COPPER STATIC WIRE/TEMP. RANGE -40 DEG F TO 150 DEG F/GENERAL APPLICATION: UNLOADING BULK TRUCKS & RAILCARS IN PLASTIC INDUSTRY

- HOS007249 3" (STANDARD LENGTHS: 20/50/100)
- HOS007250 4" (STANDARD LENGTHS: 20/50/100)
- HOS007251 5" (STANDARD LENGTHS: 20/50/100)
- HOS007252 6" (STANDARD LENGTHS: 20/50/100)

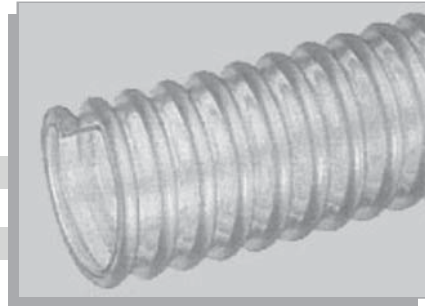

**TIGERFLEX-SERIES GC:**

GROUND COVER HOSE, POLYURETHANE LINED, HMW PVC COVER, TEMP. RANGE -40 DEG F TO 150 DEG F/GENERAL APPLICATION: DELIVERY OF MULCH, SEED, COMPOST & WOOD FIBER

- HOS007151 3" (STANDARD LENGTH: 100)
- HOS007152 4" (STANDARD LENGTH: 100)
- HOS007153 5" (STANDARD LENGTH: 100)
- HOS007154 6" (STANDARD LENGTH: 100)



**TIGERFLEX-SERIES UREVAC-3:**

POLYURETHANE LIGHTWEIGHT TRANSFER HOSE, WITH COPPER STATIC WIRE, TEMP. RANGE -40 DEG F TO 150 DEG F/GENERAL APPLICATION: GRAIN, ROOFTOP CLEANING, INSULATION BLOWING, LAWN, LEAF, MULCH, PELLETS, POWDERS

- HOS007516 3" (STANDARD LENGTHS: 50/100)
- HOS007517 4" (STANDARD LENGTHS: 50/100)
- HOS007518 5" (STANDARD LENGTHS: 50/100)
- HOS007519 6" (STANDARD LENGTHS: 50/100)
- HOS007520 8" (STANDARD LENGTHS: 50/100)

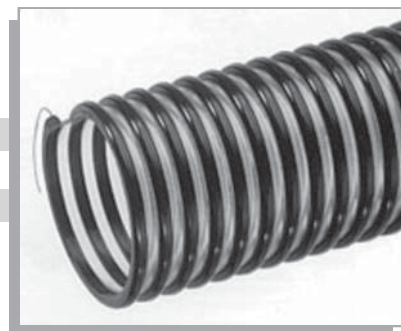

**TIGERFLEX-SERIES OV:**

OILVAC HEAVY DUTY TPU MATERIAL HANDLING HOSE (DRY OR LIQUID), TEMP. RANGE -40 DEG F TO 150 DEG F/GENERAL APPLICATION: OIL, FUEL, GREASE, PELLETS, GRAIN

- HOS007242 1" (STANDARD LENGTH: 100)
- HOS007243 1-1/4" (STANDARD LENGTH: 100)
- HOS007244 1-1/2" (STANDARD LENGTH: 100)
- HOS007245 2" (STANDARD LENGTH: 100)
- HOS007246 2-1/2" (STANDARD LENGTH: 100)
- HOS007247 3" (STANDARD LENGTH: 100)

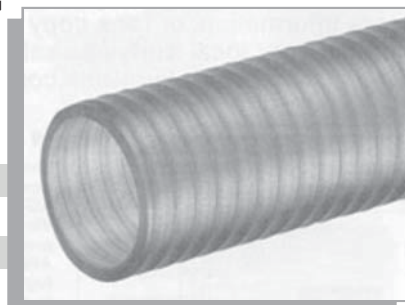

**TIGERFLEX-SERIES OR-V:**

**OIL RESISTANT PVC OIL TRANSFER HOSE, TEMP. RANGE  
-40 DEG F TO 150 DEG F**  
*GENERAL APPLICATION: LIGHT  
DUTY OIL, OIL SLURRY, HYDROCARBONS EMISSIONS*

HOS007236	3/4"	(STANDARD LENGTH: 100)
HOS007237	1"	(STANDARD LENGTH: 100)
HOS007238	1-1/4"	(STANDARD LENGTH: 100)
HOS007239	1-1/2"	(STANDARD LENGTH: 100)
HOS007240	2"	(STANDARD LENGTH: 100)
HOS007241	3"	(STANDARD LENGTH: 100)

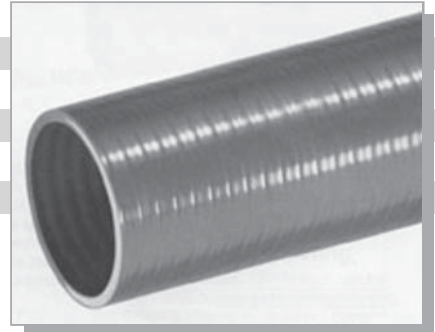
**TIGERFLEX-SERIES 2001:**

**POLYURETHANE LINED PVC, WITH STATIC WIRE,  
DRY MATERIAL HANDLING HOSE, TEMP. RANGE  
-40 DEG F TO 150 DEG F**  
*GENERAL APPLICATION: POWDERS, PELLETS, RICE,  
FLOUR, GRAIN*

HOS006838	1-1/2"	(STANDARD LENGTH: 60)
HOS006839	2"	(STANDARD LENGTH: 60)
HOS006840	2-1/5"	(STANDARD LENGTH: 60)
HOS006841	3"	(STANDARD LENGTH: 60)
HOS006842	4"	(STANDARD LENGTHS: 20/60)
HOS006843	5"	(STANDARD LENGTHS: 20/60)
HOS006844	6"	(STANDARD LENGTHS: 20/60)
HOS006845	8"	(STANDARD LENGTHS: 20/60)

**TIGERFLEX-SERIES WE:**

**HEAVY-DUTY PVC FOOD GRADE HOSE, EMBEDDED  
STATIC WIRE, MATERIAL HANDLING, DRY  
TRANSFER/TEMP. RANGE -4 DEG F TO 150  
DEG F**  
*GENERAL APPLICATION: POWDERS,  
PELLETS, GRAIN, PAPER MILL VACUUM LINES*

HOS007549	1-1/4"	(STANDARD LENGTHS: 50/60)
HOS007550	1-1/2"	(STANDARD LENGTHS: 50/60)
HOS007551	2"	(STANDARD LENGTHS: 50/60)
HOS007552	2-1/2"	(STANDARD LENGTHS: 50/60)
HOS007553	3"	(STANDARD LENGTHS: 50/60)
HOS007554	4"	(STANDARD LENGTHS: 50/60)
HOS007555	5"	(STANDARD LENGTHS: 20/50/60)
HOS007556	6"	(STANDARD LENGTHS: 20/50/60)





**TIGERFLEX-SERIES UBK:**

**POLYURETHANE LINED, ABRASION RESISTANT, PVC HOSE, DRY MATERIAL, TEMP. RANGE -40 DEG F TO 150 DEG F**

**GENERAL APPLICATION:**

*ABRASIVE ROOF ROCK SAND/SHOT BLAST*

HOS007461	2" (STANDARD LENGTHS: 50/100)
HOS007462	2-1/2" (STANDARD LENGTHS: 50/100)
HOS007463	3" (STANDARD LENGTHS: 50/100)
HOS007464	4" (STANDARD LENGTHS: 50/100)
HOS007466	5" (STANDARD LENGTHS: 20/50/100)
HOS007467	6" (STANDARD LENGTHS: 20/50/100)
HOS007470	8" (STANDARD LENGTHS: 20/50)



**TIGERFLEX-SERIES UREFLEX-1:**

**POLYURETHANE LINED, ABRASION RESISTANT, PVC HOSE, DRY MATERIAL, TEMP. RANGE -40 DEG F TO 150 DEG F**

**GENERAL APPLICATION:**

*ABRASIVE, GRAIN, FLY ASH, ROOF ROCK, SAND/SHOT BLAST*

HOS007473	1-1/4" (STANDARD LENGTH: 100)
HOS007474	1-1/2" (STANDARD LENGTHS: 50/100)
HOS007475	2" (STANDARD LENGTHS: 50/100)
HOS007476	2-1/2" (STANDARD LENGTHS: 50/100)
HOS007477	3" (STANDARD LENGTHS: 50/100)
HOS007478	3-1/2" (STANDARD LENGTHS: 50/100)
HOS007479	4" (STANDARD LENGTHS: 50/100)
HOS007480	5" (STANDARD LENGTHS: 20/50/100)
HOS007481	6" (STANDARD LENGTHS: 20/50/100)
HOS007482	8" (STANDARD LENGTHS: 20/50)



**TIGERFLEX-SERIES UREFLEX-2:**

**POLYURETHANE LINED, ABRASION RESISTANT, PVC HOSE, DRY MATERIAL, TEMP. RANGE -40 DEG F TO 150 DEG F**

**GENERAL APPLICATION:**

*ABRASIVE, GRAIN, FLY ASH, ROOF ROCK, SAND/SHOT BLAST*

HOS007484	1-1/2" (STANDARD LENGTH: 100)
HOS007485	2" (STANDARD LENGTH: 100)
HOS007486	2-1/2" (STANDARD LENGTH: 100)
HOS007487	3" (STANDARD LENGTHS: 50/100)
HOS007488	4" (STANDARD LENGTHS: 50/100)
HOS007489	5" (STANDARD LENGTHS: 20/50/100)
HOS007490	6" (STANDARD LENGTHS: 20/50/100)
HOS007491	8" (STANDARD LENGTHS: 20/50)

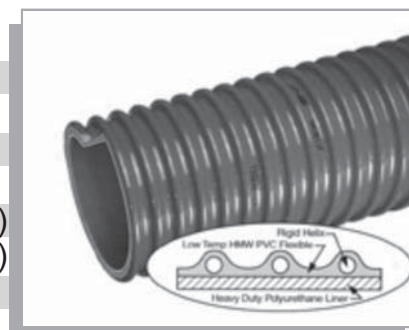

**TIGERFLEX-SERIES 2020:**

**REINFORCED POLYURETHANE LINED,  
REINFORCED, EMBEDDED STATIC WIRE,  
OUTDOOR, DRY, MATERIAL HANDLING HOSE,  
TEMP. RANGE -40 DEG F TO 150 DEG  
FIGENERAL APPLICATION: POWDERS, PELLETS,  
GRAIN, HOSE DRY FOOD TRANSFER**

HOS006862 3"  
HOS006863 4"  
HOS006864 5"  
HOS006865 6"

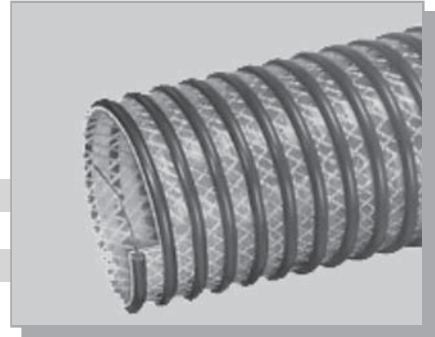
**TIGERFLEX-SERIES UREVAC-1:**

**POLYURETHANE LIGHTWEIGHT BLOWER HOSE,  
TEMP. RANGE -40 DEG F TO 150 DEG FIGENERAL  
APPLICATION: LAWN CLEANING, LEAF  
COLLECTION, FUME REMOVAL, INSULATION  
BLOWING**

HOS007500 1-1/2" (STANDARD LENGTH: 50)  
HOS007501 2" (STANDARD LENGTH: 50)  
HOS007502 2-1/2" (STANDARD LENGTH: 50)  
HOS007503 3" (STANDARD LENGTH: 50)  
HOS007504 4" (STANDARD LENGTH: 50)  
HOS007505 5" (STANDARD LENGTH: 50)  
HOS007506 6" (STANDARD LENGTH: 50)  
HOS007507 8" (STANDARD LENGTH: 50)

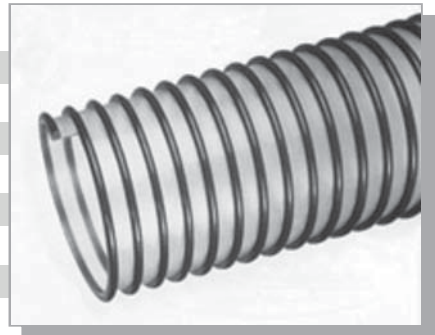
**TIGERFLEX-SERIES UREVAC-2:**

**POLYURETHANE LINED LIGHTWEIGHT PVC MATERIAL  
HANDLING HOSE, TEMP. RANGE -40 DEG F TO 150 DEG  
FIGENERAL APPLICATION: GRAIN CLEANUP, ROOFTOP  
CLEANING, LAWN, LEAF & MULCH COLLECTION**

HOS007508 1-1/2" (STANDARD LENGTH: 60)  
HOS007509 2" (STANDARD LENGTH: 60)  
HOS007510 2-1/2" (STANDARD LENGTH: 60)  
HOS007511 3" (STANDARD LENGTH: 60)  
HOS007512 4" (STANDARD LENGTH: 60)  
HOS007513 5" (STANDARD LENGTH: 60)  
HOS007514 6" (STANDARD LENGTH: 60)  
HOS007515 8" (STANDARD LENGTH: 20)

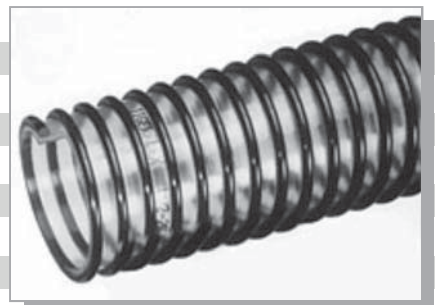

**TIGERFLEX-SERIES G:**

**MEDIUM DUTY PVC GENERAL PURPOSE SUCTION & TRANSFER HOSE, TEMP. RANGE -4**

**DEG F TO 150 DEG F** GENERAL APPLICATION: CONSTRUCTION & MINING, ROCK DUSTING, WELLPOINT & AGRI-FOAM SYSTEM, LIQUID FERTILIZER TRANSFER

HOS007141	3/4"	(STANDARD LENGTH: 100)
HOS007142	1"	(STANDARD LENGTH: 100)
HOS007143	1-1/4"	(STANDARD LENGTH: 100)
HOS007144	1-1/2"	(STANDARD LENGTH: 100)
HOS007145	2"	(STANDARD LENGTH: 100)
HOS007146	2-1/2"	(STANDARD LENGTH: 100)
HOS007147	3"	(STANDARD LENGTH: 100)
HOS007148	4"	(STANDARD LENGTH: 100)
HOS007149	6"	(STANDARD LENGTHS: 20/100)
HOS007150	8"	(STANDARD LENGTH: 20)

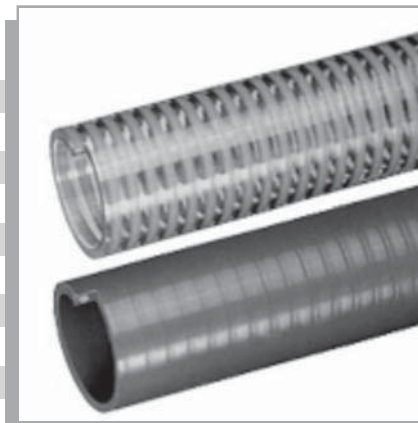

**KANAFLEX-SERIES 180AR:**

**HEAVY-DUTY ABRASION-RESISTANT SUCTION & HOSE FOR ABRASIVES SUCH AS CRUSHED ROCK, SAND, GRAVEL, CEMENT POWDER, DRY FERTILIZER, IRON ORE & GRAINS**

HOS006801	1-1/4"	(STANDARD LENGTH: 100)
HOS006802	1-1/2"	(STANDARD LENGTH: 100)
HOS006803	2"	(STANDARD LENGTH: 100)
HOS006804	2-1/2"	(STANDARD LENGTH: 100)
HOS006805	3"	(STANDARD LENGTH: 100)
HOS006806	3-1/2"	(STANDARD LENGTH: 100)
HOS006807	4"	(STANDARD LENGTH: 100)
HOS006809	5"	(STANDARD LENGTHS: 50/100)
HOS006811	6"	(STANDARD LENGTHS: 50/100)
HOS006813	7"	(STANDARD LENGTH: 50)
HOS006814	8"	(STANDARD LENGTH: 50)
HOS006799	10"	(STANDARD LENGTH: 20)
HOS006800	12"	(STANDARD LENGTH: 20)



**KANAFLEX-SERIES 180HR:**

**HEAVY-DUTY SUCTION HOSE FOR HIGHER TEMP & ABRASION APPLICATIONS/TEMP -40 DEG F TO 220 DEG F / FLY ASH, CRUSHED ROCK, SAND, GRAVEL, OR CEMENT POWDER**

HOS006822	4"	(STANDARD LENGTH: 100)
HOS006824	6"	(STANDARD LENGTH: 100)
HOS006827	8"	(STANDARD LENGTH: 50)



**KANAFLEX-SERIES 100CL:****WATER SUCTION HOSE/TEMP. -13 DEG F TO 158 DEG F**

HOS006721	1" (STANDARD LENGTH: 100)
HOS006723	1-1/4" (STANDARD LENGTH: 100)
HOS006724	1-1/2" (STANDARD LENGTH: 100)
HOS006725	2" (STANDARD LENGTH: 100)
HOS006726	2-1/2" (STANDARD LENGTH: 100)
HOS006727	3" (STANDARD LENGTH: 100)
HOS006728	4" (STANDARD LENGTH: 100)
HOS006729	6" (STANDARD LENGTHS: 50/100)
HOS006730	8" (STANDARD LENGTH: 25)
HOS006722	10" (STANDARD LENGTH: 20)

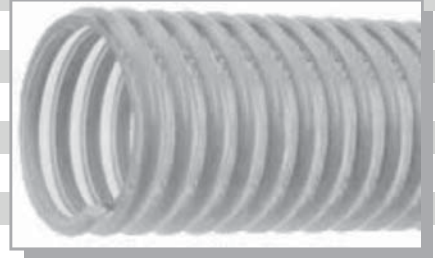
**KANAFLEX-SERIES 110CL:****HEAVY-DUTY WATER SUCTION HOSE/TEMP. -13 DEG F TO 158 DEG F**

HOS006738	3/4" (STANDARD LENGTH: 100)
HOS006739	1" (STANDARD LENGTH: 100)
HOS006740	1-1/4" (STANDARD LENGTH: 100)
HOS006741	1-1/2" (STANDARD LENGTH: 100)
HOS006742	2" (STANDARD LENGTH: 100)
HOS006743	2-1/2" (STANDARD LENGTH: 100)
HOS006744	3" (STANDARD LENGTH: 100)
HOS006745	4" (STANDARD LENGTH: 100)
HOS006746	6" (STANDARD LENGTHS: 50/100)
HOS006747	8" (STANDARD LENGTH: 25)

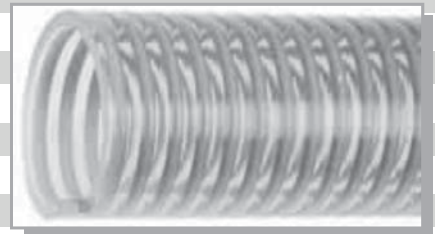
**KANAFLEX-SERIES 112CL:****HEAVY-DUTY WATER SUCTION HOSE/TEMP. -13 DEG F TO 158 DEG F**

HOS006748	1-1/4" (STANDARD LENGTH: 100)
HOS006749	1-1/2" (STANDARD LENGTH: 100)
HOS006750	2" (STANDARD LENGTH: 100)
HOS006751	2-1/2" (STANDARD LENGTH: 100)
HOS006752	3" (STANDARD LENGTH: 100)
HOS006753	4" (STANDARD LENGTH: 100)

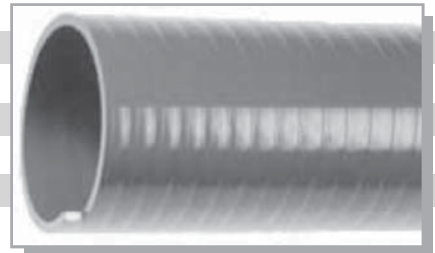
**TIGERFLEX-SERIES ST200SFG:****PNEUMATIC CONVEYING OF LIGHTWEIGHT SOLIDS/  
FOR POWDERS & PLASTIC PELLETS**

HOS007296	1-1/2" (STANDARD LENGTHS: 50/100)
HOS007297	2" (STANDARD LENGTHS: 50/100)
HOS007298	2-1/2" (STANDARD LENGTHS: 50/100)
HOS007299	3" (STANDARD LENGTHS: 50/100)
HOS007300	4" (STANDARD LENGTHS: 50/100)



**KANAFLEX KANALINE-SERIES SR:**

**HEAVY-DUTY SUCTION & DISCHARGE HOSE/***FOR FISH SUCTION & RENTAL/CONSTRUCTION PUMPING*

- HOS007290 1-1/2" (STANDARD LENGTH: 100)
- HOS007291 2" (STANDARD LENGTH: 100)
- HOS007292 3" (STANDARD LENGTH: 100)
- HOS007293 4" (STANDARD LENGTH: 100)
- HOS007294 6" (STANDARD LENGTH: 100)
- HOS007295 8" (STANDARD LENGTH: 25)
- HOS007289 10" (STANDARD LENGTH: 20)

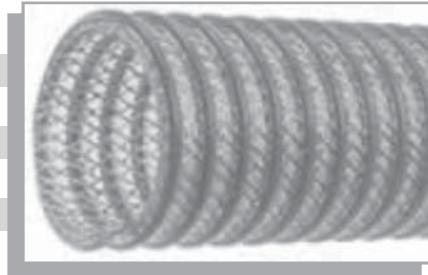

**KANAFLEX-SERIES 180BL:**

**SUCTION & LIGHT BLOWING HOSE, FOR LIGHTWEIGHT**  
*ABRASIVES/TEMP. -40 DEG F TO 158 DEG F/  
ROCKWOOL, FIBERGLASS, SAWDUST, GRAIN,  
INSULATION & CEMENT DUST*

- HOS006815 2-1/2" (STANDARD LENGTH: 100)
- HOS006816 3" (STANDARD LENGTH: 100)
- HOS006817 4" (STANDARD LENGTH: 100)
- HOS006818 5" (STANDARD LENGTHS: 50/100)
- HOS006819 6" (STANDARD LENGTHS: 50/100)
- HOS006820 8" (STANDARD LENGTH: 50)

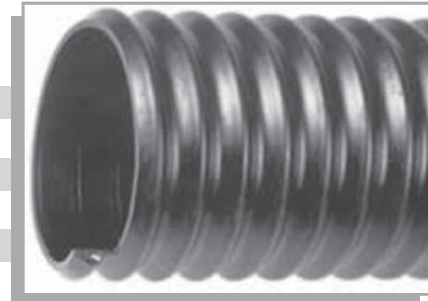

**KANAFLEX-SERIES 220RS:**

**HEAVY-DUTY LIQUID SUCTION HOSE/TEMP. -40 DEG F TO 158 DEG F/**  
*FOR CONSTRUCTION DEWATERING LIQUID  
WASTE, CESSPOOL CLEANING, SEPTIC  
HANDLING, AGRICULTURE APPLICATIONS  
& MARINE USE*

- HOS006878 1-1/2" (STANDARD LENGTH: 100)
- HOS006879 2" (STANDARD LENGTH: 100)
- HOS006880 2-1/2" (STANDARD LENGTH: 100)
- HOS006881 3" (STANDARD LENGTH: 100)
- HOS006882 4" (STANDARD LENGTH: 100)
- HOS006883 6" (STANDARD LENGTH: 100)

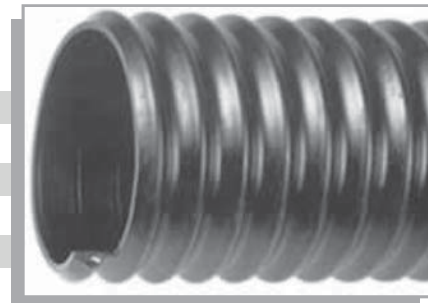

**TIGERFLEX-SERIES 390SD:**

**HEAVY-DUTY SUCTION & DISCHARGE HOSE/TEMP. -40 DEG F TO 158 DEG F/**  
*FOR CONSTRUCTION, RENTAL, & AGRICULTURAL INDUSTRIES-CHEMICALS,  
LIQUID FERTILIZERS & DEWATERING/*

- HOS006923 1-1/4" (STANDARD LENGTH: 100)
- HOS006924 1-1/2" (STANDARD LENGTH: 100)
- HOS006925 2" (STANDARD LENGTH: 100)
- HOS006926 3" (STANDARD LENGTH: 100))

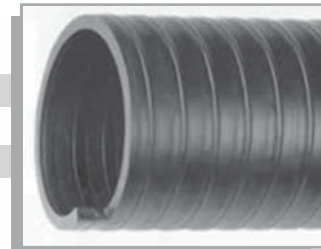

**KANAFLEX-SERIES 300EPDM:**

**HEAVY-DUTY LIQUID SUCTION HOSE/TEMP. -40 DEG F TO 158 DEG F/  
FOR CONSTRUCTION DEWATERING, LIQUID WASTE,  
CESSPOOL CLEANING, SEPTIC HANDLING,  
AGRICULTURAL APPLICATION & MARINE USE**

HOS006901	1" (STANDARD LENGTH: 100)
HOS006902	1-1/4" (STANDARD LENGTH: 100)
HOS006903	1-1/2" (STANDARD LENGTH: 100)
HOS006904	2" (STANDARD LENGTH: 100)
HOS006905	2-1/2" (STANDARD LENGTH: 100)
HOS006906	3" (STANDARD LENGTH: 100)
HOS006907	4" (STANDARD LENGTH: 100)
HOS006908	6" (STANDARD LENGTHS: 60/100)

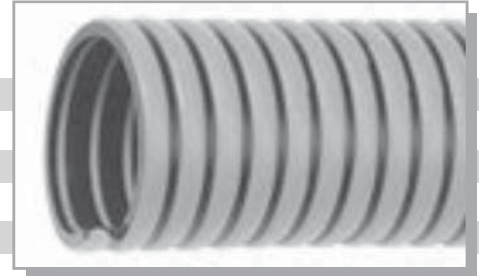
**KANAFLEX-SERIES 160BL:**

**LAY FLAT HOSE, FOR WATER DISCHARGE/TEMP. -13 DEG F TO 158 DEG F**

HOS006782	1-1/2" (STANDARD LENGTH: 300)
HOS006783	2" (STANDARD LENGTH: 300)
HOS006784	2-1/2" (STANDARD LENGTH: 300)
HOS006785	3" (STANDARD LENGTH: 300)
HOS006786	4" (STANDARD LENGTH: 300)
HOS006787	6" (STANDARD LENGTH: 300)
HOS006788	8" (STANDARD LENGTH: 300)

**KANAFLEX-SERIES 620WD:**

**GENERAL DUCTING & BLOWER APPLICATIONS/  
TEMP -40 DEG F TO 220 DEG F/FOR LIGHTWEIGHT  
ABRASIVES-SAWDUST, GRASS CLIPPINGS,  
STREET REFUSE & COTTON PICKERS**

HOS006997	2-1/2" (STANDARD LENGTH: 50)
HOS006998	3" (STANDARD LENGTH: 50)
HOS006999	4" (STANDARD LENGTH: 50)
HOS007000	5" (STANDARD LENGTH: 50)
HOS007001	6" (STANDARD LENGTH: 50)
HOS007002	7" (STANDARD LENGTH: 50)
HOS007003	8" (STANDARD LENGTH: 50)
HOS006995	10" (STANDARD LENGTH: 50)
HOS006996	12" (STANDARD LENGTH: 25)

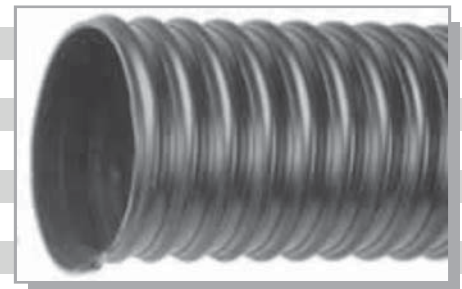

**KANAFLEX-SERIES 630ED:**

**MEDIUM-DUTY BLOWER & DUCTING HOSE/TEMP. -40 DEG F TO 158 DEG F**  
 FOR HAY BAILING, STREET REFUSE, GRAINDUST, WOOD CHIPS, COTTON PICKERS, STRAW BLOWING, LEAF & GRASS COLLECTION

- HOS007004 2" (STANDARD LENGTH: 50)
- HOS007005 2-1/2" (STANDARD LENGTH: 50)
- HOS007006 3" (STANDARD LENGTH: 50)
- HOS007007 4" (STANDARD LENGTH: 50)
- HOS007008 6" (STANDARD LENGTH: 50)
- HOS007009 8" (STANDARD LENGTH: 50)

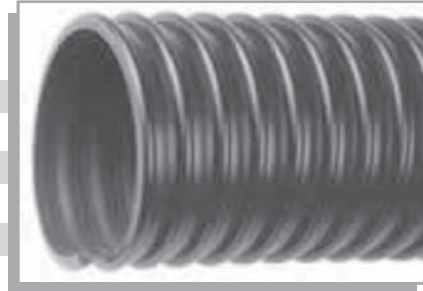

**KANAFLEX-SERIES 660YD:**

**HEAVY-DUTY DUCTING HOSE/TEMP -40 DEG F TO 158 DEG F**  
 FOR DUCT CLEANING, COMMERCIAL GRASS & LEAF COLLECTION, CEMENT DUST RECOVERY, BLAST CABINET DUST COLLECTION, GRAIN AUGER DOWNSPOUTS

- HOS007012 4" (STANDARD LENGTH: 50)
- HOS007013 5" (STANDARD LENGTH: 50)
- HOS007014 6" (STANDARD LENGTH: 50)
- HOS007015 8" (STANDARD LENGTH: 50)
- HOS007011 10" (STANDARD LENGTH: 25)

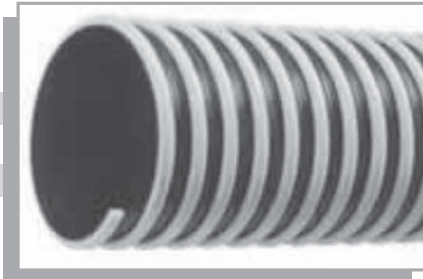

**TEXTILE CORD AIR DRILL HOSE:**

**HIGH QUALITY AIR HOSE/TEMP -30 DEG F TO 185 DEG F**  
 FOR MINING & CONSTRUCTION SERVICE

- HOS007332 1/2" (STANDARD LENGTH: 100)
- HOS007333 3/4" (STANDARD LENGTH: 100)
- HOS007334 1" (STANDARD LENGTH: 100)
- HOS007335 1-1/4" (STANDARD LENGTH: 100)
- HOS007336 1-1/2" (STANDARD LENGTH: 100)
- HOS007337 2" (STANDARD LENGTH: 100)
- HOS007338 2-1/2" (STANDARD LENGTH: 50)
- HOS007339 3" (STANDARD LENGTH: 50)
- HOS007340 4" (STANDARD LENGTH: 50)

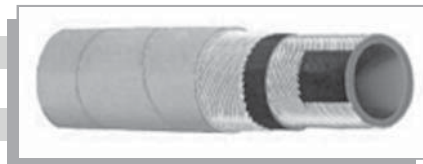

## 150 PSI EPDM MULTI-PURPOSE WATER SUCTION HOSE:

TEMP. -30 DEG F TO 158 DEG F

HOS007341	1" (STANDARD LENGTH: 100)
HOS007343	1-1/4" (STANDARD LENGTH: 100)
HOS007344	1-1/2" (STANDARD LENGTH: 100)
HOS007345	2" (STANDARD LENGTH: 100)
HOS007346	2-1/2" (STANDARD LENGTH: 100)
HOS007347	3" (STANDARD LENGTH: 100)
HOS007348	3-1/2" (STANDARD LENGTH: 100)
HOS007349	4" (STANDARD LENGTH: 100)
HOS007350	5" (STANDARD LENGTHS: 20/50)
HOS007351	6" (STANDARD LENGTHS: 20/25/50)
HOS007352	8" (STANDARD LENGTHS: 20/25)
HOS007343	10" (STANDARD LENGTH: 20)

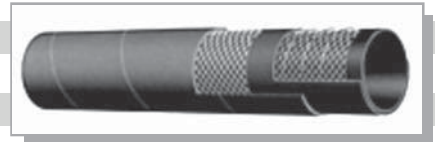

## MATERIAL HANDLING HOSE:

SUCTION OF WET OR DRY MATERIAL/TEMP -30 DEG F TO 185 DEG F

HOS007443	2" (STANDARD LENGTH: 100)
HOS007444	3" (STANDARD LENGTH: 100)
HOS007445	4" (STANDARD LENGTHS: 50/100)
HOS007446	5" (STANDARD LENGTH: 20)
HOS007447	6" (STANDARD LENGTH: 20)
HOS007449	8" (STANDARD LENGTH: 20)



## OIL RIGGER/OIL FIELD SUCTION HOSE:

FOR HANDLING CRUDE OIL ONLY/TEMP. -22 DEG F TO 185 DEG F

HOS007412	2" (STANDARD LENGTH: 100)
HOS007413	3" (STANDARD LENGTH: 100)
HOS007414	4" (STANDARD LENGTH: 100)
HOS007415	6" (STANDARD LENGTHS: 20/100)



## PETROLEUM SUCTION HOSE:

FOR SUCTION & DISCHARGE APPLICATIONS IN TRUCK & TANK CAR  
TRANSFER/OF GASOLINE, OIL & OTHER PETROLEUM-BASED  
PRODUCTS

HOS007416	3/4" (STANDARD LENGTH: 100)
HOS007417	1" (STANDARD LENGTH: 100)
HOS007418	1-1/4" (STANDARD LENGTH: 100)
HOS007419	1-1/2" (STANDARD LENGTH: 100)
HOS007420	2" (STANDARD LENGTH: 100)
HOS007424	2-1/2" (STANDARD LENGTH: 100)
HOS007425	3" (STANDARD LENGTH: 100)
HOS007426	4" (STANDARD LENGTH: 100)
HOS007427	6" (STANDARD LENGTHS: 20/100)





**RED PETROLEUM SUCTION HOSE:**

FOR SUCTION & DISCHARGE APPLICATIONS IN TRUCK & TANK CAR TRANSFER/TEMP. -40 DEG F TO 212 DEG F / OF GASOLINE, OIL & OTHER PETROLEUM-BASED PRODUCTS

T605AH150	1-1/2" (STANDARD LENGTH: 100)
T605AH200	2" (STANDARD LENGTH: 100)
T605AH300	3" (STANDARD LENGTH: 100)
T605AH400	4" (STANDARD LENGTH: 100)



**OIL DISCHARGE HOSE:**

DISCHARGE HOSE/TEMP -20 DEG F TO 212 DEG F / FOR USE ON TRUCKS, DOCKS, OR BARGES WHERE SOFT WALL HOSE IS REQUIRED

HOS007429	1-1/2" (STANDARD LENGTH: 100)
HOS007430	2" (STANDARD LENGTH: 100)
HOS007431	3" (STANDARD LENGTH: 100)
HOS007432	4" (STANDARD LENGTH: 100)

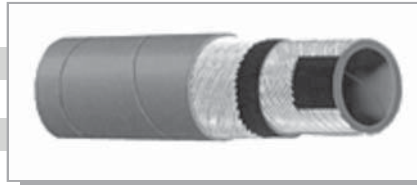

**HIGH QUALITY HOT AIR BLOWER HOSE:**

HANDLING HOT AIR UNDER PRESSURE BETWEEN AIR COMPRESSOR & DRY BULK TANK/TEMP -40 DEG F TO 330 DEG F

HOS007454	2" (STANDARD LENGTHS: 100)
HOS007455	3" (STANDARD LENGTHS: 100)
HOS007456	4" (STANDARD LENGTHS: 100)



**PORTHOSE:**

HOS007043	8"x11' HEAVY-DUTY HOSE
HOS007045	8"x12' HEAVY-DUTY HOSE
HOS007046	8"x13' HEAVY-DUTY HOSE
HOS007048	8"x16' HEAVY-DUTY HOSE
HOS007049	8"x17' HEAVY-DUTY HOSE
HOS007050	8"x18' HEAVY-DUTY HOSE
8108-BC	8"x11' BLUCOR SUPER HEAVY-DUTY HOSE
8108-BH	8"x5'-8" BOOM JUMPER HOSE
8108-5	8"x5' COMBOVAX JUMPER HOSE
HOS007067	8"x5'-6"
HOS007068	8"x5'-8"

**PLASTIC LINE HOSE:**

HOS007253	2"x100'
HOS007254	4"x100'
HOS007255	6"x100'

**GALVANIZED FLEX STEEL HOSE:****.014-.016 WALL THICKNESS**

PIP008601	2"x25'
PIP008602	3"x25'
PIP008603	4"x25'
PIP008604	5"x25'
PIP008605	6"x25'
PIP008606	7"x25'
PIP008607	8"x25'
PIP008608	9"x25'
PIP008597	10"x25'
PIP008598	11"x25'
PIP008599	12"x25'
PIP008600	14"x25'

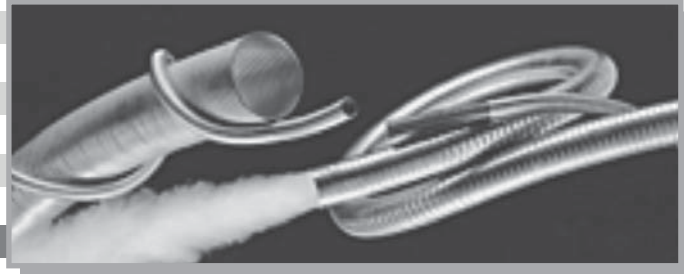
**.018-.020 WALL THICKNESS**

PIP008614	2"x25'
PIP008615	3"x25'
PIP008616	4"x25'
PIP008617	5"x25'
PIP008618	6"x25'
PIP008619	7"x25'
PIP008620	8"x25'
PIP008621	9"x25'

**SEWER CLEANING HOSE:**

4PSH-8	1/2" 4,000 PSI (BLUE)
HPSH-12	3/4" 2,500 PSI (ORANGE)
3PSH-12	3/4" 3,000 PSI (BLUE)
HPSH-16	1" 2,500 PSI (ORANGE)
3PSH-16	1" 3,000 PSI (BLUE)

**CANALKLER SEWER JETTING HOSE:****TRELLEBORG**

31600500	1/2" 2,900 PSI
31600750	3/4" 2,900 PSI
31600100	1" 2,900 PSI
31600125	1-1/4" 2,900 PSI
31600150	1-1/2" 2,900 PSI

**PLAIN END ALUMINUM TUBE:**

PIP008209	2"x.050 WALL
PIP008255	3"x.050 WALL
PIP008291	4"x.050 WALL
PIP008292	4"x.072 WALL
PIP008345	5"x.052 WALL
PIP008361	6"x.050 WALL
PIP008362	6"x.058 WALL
PIP008363	6"x.083 WALL
PIP008364	6"x.125 WALL
PIP008475	7"x.060 WALL
PIP008485	8"x.050 WALL
PIP008486	8"x.064 WALL
PIP008487	8"x.072 WALL
PIP008491	8"x.094 WALL
PIP008174	10"x.051 WALL
PIP008175	10"x.064 WALL
PIP008176	10"x.094 WALL
PIP008188	12"x.064 WALL

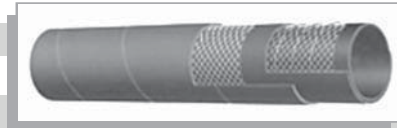

**ALUMINUM TUBE W/PRESS-ON ENDS:**

**ALUMINUM VACUUM TUBING WITH PRESSED-ON STEEL ENDS**

**4" DIAMETER TUBING WITH .072 WALL**

- 4"x 3'-072
- 4"x 4'-072
- 4"x 5'-072
- 4"x 6'-072
- 4"x10'-072
- 4"x20'-072

**6" DIAMETER TUBING WITH .083 WALL**

- 6"x 3'-083
- 6"x 4'-083
- 6"x 5'-083
- 6"x 6'-083
- 6"x 7'-083
- 6"x 8'-083
- 6"x10'-083
- 6"x20'-083



**8" DIAMETER TUBING WITH .072 WALL**

- 8"x 3'-072
- 8"x 4'-072
- 8"x 5'-072
- 8"x 6'-072
- 8"x 7'-072
- 8"x 8'-072
- 8"x10'-072
- 8"x20'-072

**TUBE W/WELD-ON ENDS:****STEEL VACUUM TUBING WITH WELD-ON ENDS****4" DIAMETER TUBING WITH 14 GAUGE WALL**

4"x 3'-14 GAUGE  
 4"x 4'-14 GAUGE  
 4"x 5'-14 GAUGE  
 4"x 6'-14 GAUGE  
 4"x10'-14 GAUGE  
 4"x20'-14 GAUGE

**6" DIAMETER TUBING WITH 14 GAUGE WALL**

6"x 3'-14 GAUGE  
 6"x 4'-14 GAUGE  
 6"x 5'-14 GAUGE  
 6"x 6'-14 GAUGE  
 6"x 7'-14 GAUGE  
 6"x 8'-14 GAUGE  
 6"x10'-14 GAUGE  
 6"x20'-14 GAUGE

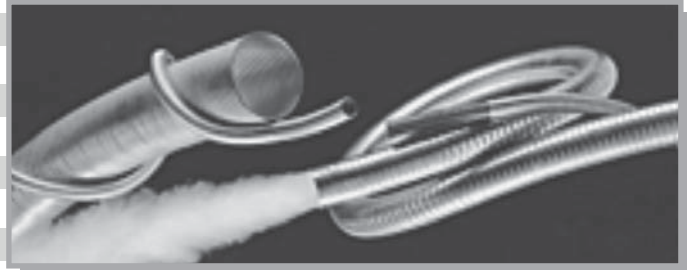
**8" DIAMETER TUBING WITH 14 GAUGE WALL**

8"x 3'-14 GAUGE  
 8"x 4'-14 GAUGE  
 8"x 5'-14 GAUGE  
 8"x 6'-14 GAUGE  
 8"x 7'-14 GAUGE  
 8"x 8'-14 GAUGE  
 8"x10'-14 GAUGE  
 8"x20'-14 GAUGE

**ALUMINUM VACUUM TUBING WITH WELD-ON ENDS****4" DIAMETER TUBING WITH .072 WALL**

4"x 3'-072  
 4"x 4'-072  
 4"x 5'-072  
 4"x 6'-072  
 4"x10'-072  
 4"x20'-072

**6" DIAMETER TUBING WITH .083 WALL**

6"x 3'-083  
 6"x 4'-083  
 6"x 5'-083  
 6"x 6'-083  
 6"x 7'-083  
 6"x 8'-083  
 6"x10'-083  
 6"x20'-083

**8" DIAMETER TUBING WITH .072 WALL**

8"x 3'-072  
 8"x 4'-072  
 8"x 5'-072

**8" DIAMETER TUBING WITH .072 WALL, CONT'D.**

8"x 6'-072  
 8"x 7'-072  
 8"x 8'-072  
 8"x10'-072  
 8"x20'-072

**VACTOR STYLE TUBING:****ALUMINUM VACUUM TUBING****WITH RIVETED STEEL FLANGE**

6"x 3'-VRFS  
 6"x 4'-VRFS  
 6"x 5'-VRFS  
 6"x 6'-VRFS  
 6"x 7'-VRFS  
 6"x 8'-VRFS  
 6"x10'-VRFS  
 6"x20'-VRFS



8"x 3'-VRFS  
 8"x 4'-VRFS  
 8"x 5'-VRFS  
 8"x 6'-VRFS  
 8"x 7'-VRFS  
 8"x 8'-VRFS  
 8"x10'-VRFS  
 8"x20'-VRFS

**WITH WELD-ON STEEL FLANGE**

6"x 3'-VWF  
 6"x 4'-VWF  
 6"x 5'-VWF  
 6"x 6'-VWF  
 6"x 7'-VWF  
 6"x 8'-VWF  
 6"x10'-VWF  
 6"x20'-VWF



8"x 3'-VWF  
 8"x 4'-VWF  
 8"x 5'-VWF  
 8"x 6'-VWF  
 8"x 7'-VWF  
 8"x 8'-VWF  
 8"x10'-VWF  
 8"x20'-VWF

**STEEL VACUUM TUBING****14 GAUGE TUBING WITH RIVETED FLANGES**

6"x 3'-14VRFS  
 6"x 4'-14VRFS  
 6"x 5'-14VRFS  
 6"x 6'-14VRFS  
 6"x 7'-14VRFS  
 6"x 8'-14VRFS

**14 GAUGE TUBING WITH RIVETED FLANGES, CONT'D.**

6"x10'-14VRFS

6"x20'-14VRFS

**14 GAUGE STEEL TUBING WITH RIVETED FLANGES**

8"x 3'-14VRFS

8"x 4'-14VRFSE

8"x 5'-14VRFS

8"x 6'-14VRFS

8"x 7'-14VRFS

8"x 8'-14VRFS

8"x10'-14VRFS

8"x20'-14VRFS

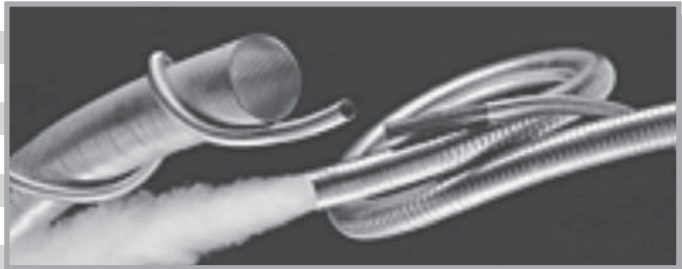
**14 GAUGE STEEL TUBING WITH WELD-ON FLANGES**

6"x 3'-14VWF

6"x 4'-14VWF

6"x 5'-14VWF

6"x 6'-14VWF

6"x 7'-14VWF

6"x 8'-14VWF

6"x10'-14VWF

6"x20'-14VWF

**STEEL TUBING WITH .072 WALL**

8"x 3'-14VWF

8"x 4'-14VWF

8"x 5'-14VWF

8"x 6'-14VWF

8"x 7'-14VWF

8"x 8'-14VWF

8"x10'-14VWF

8"x20'-14VWF

**FITTINGS & COUPLERS****VACTOR STYLE FLANGES:**

VRFS600 6" STEEL RIVETED FLANGE

VWF600 6" WELD FLANGE

VRFS800 8" STEEL RIVETED FLANGE

VWF800 8" WELD FLANGE

**VACTOR STYLE CLAMPS:**

VC600 6"

VC800 8"

**FITTINGS & COUPLERS**

**RINGLOCK HOSE/PIPE CLAMP:**

- CLA000891 3"
- CLA000974 4"
- CLA000975 5"
- CLA000976 6"
- CLA000978 8"
- CLA000890 10"
- GAS022394 4" GASKET
- GAS022310 6" GASKET
- GAS022332 8" GASKET



**REDUCERS:**

- PIP008682 4" TO 3"
- PIP008683 6" TO 4"
- PIP008685 8" TO 4"
- PIP008688 8" TO 6"
- PIP008684 6" TO 4" (MALE TO MALE)
- PIP008687 8" TO 4" (MALE TO MALE)
- PIP008690 8" TO 6" (MALE TO MALE)



**WATER RINGS:**

- NOZ008112 6"
- NOZ008113 8"



**END CAPS:**

- FIT005559 3"
- FIT005562 4"
- FIT005563 5"
- FIT005565 6"
- FIT005570 8"
- FIT005558 10"



**END PLUGS:**

- FAS002834 3"
- FAS002835 4"
- FAS002836 6"
- AO12393 8"



**SAFETY INLINE VAC RELIEF VALVE:**

- VAL012097 4"
- VAL012099 6"
- VAL012012 8"



**SAFETY INLINE VAC RELIEF VALVE W/CAMLOCKS:**

- VAL012098 4"
- VAL012100 6"
- VAL012103 8"

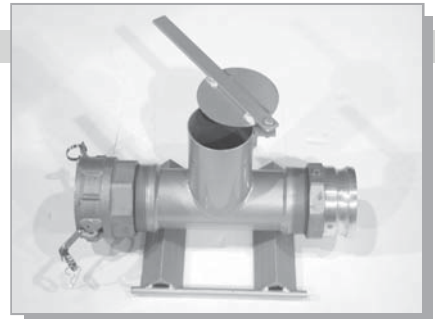

**LINE TEE:**

- PIP008674 4"
- PIP008675 6"
- PIP008677 8"



**END TEE:**

- FIT005589 4"
- FIT005590 6"
- FIT005591 8"



**DRUM LOADER LID:**

- FIT021008 4"
- CAT022110 6"





**PRESSURE CANNON ADAPTER:**

PIP008679 6" INLET

PIP008680 8" INLET

**BLACK STEEL COUPLER SET:**

FIT005572 3"

FIT005573 4"

FIT005574 5"

FIT005575 6"

FIT005576 8"

FIT005571 10"

**BLACK STEEL MALE COUPLER:**

FIT004426 3"

CON001100 4"

CON01091 5"

CON001078 6"

CON001079 8"

CON01089 10"

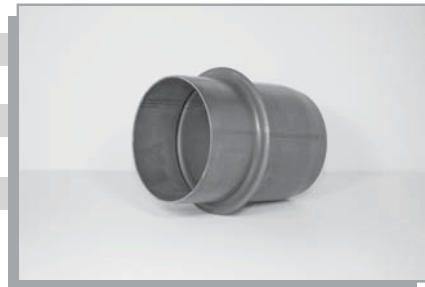
**BLACK STEEL FEMALE COUPLER:**

FIT005612 3"

CON001075 4"

CON001100 5"

CON001092 6"

CON001093 8"

CON001080 10"

**GALVANIZED COUPLER SET:**

GCS300 3"

FIT005647 4"

FIT005648 6"

FIT005649 8"

FIT005646 10"



**GALVANIZED MALE COUPLER:**

GMC300	3"
FIT005678	4"
FIT005679	6"
FIT005680	8"
FIT005677	10"

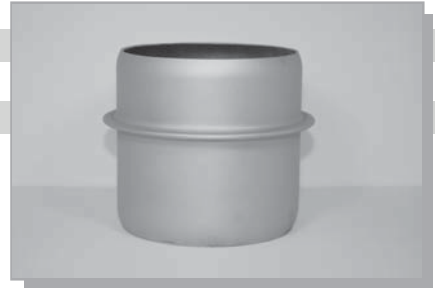

**GALVANIZED FEMALE COUPLER:**

GFC300	3"
FIT005673	4"
FIT005674	6"
FIT001084	8"
CON001085	10"



**BLACK STEEL MALE WELD-ON COUPLER:**

FIT005848	4"
CON001056	6"
FIT003971	8"
FIT005846	10"



**BLACK STEEL FEMALE WELD-ON COUPLER:**

FIT005841	4"
CON001071	6"
FIT003971	8"
FIT005839	10"



**ALUMINUM MALE WELD-ON  
COUPLER:**

CON001116	4"
CON001123	6"
FIT005504	8"
FIT004104	10"

**ALUMINUM FEMALE WELD-ON  
COUPLER:**

CON001115	4"
PIP008369	6"
FIT005492	8"
FIT004095	10"

**90 DEGREE ROUND BACK ELBOW:**

FIT003605	4"
FIT003607	6"
FIT003609	8"

**90 DEGREE HEAVY DUTY ELBOW:**

FIT003606	3"
FIT003608	4"
FIT006313	6"
FIT003614	8"



**45 DEGREE ELBOW:**

- FIT005095 4"
- FIT005096 6"
- PIP008297 8"



**WYE:**

- PIP008704 4"x3"x3"
- PIP008706 6"x3"x3"
- PIP008707 6"x4"x4"
- PIP008709 8"x4"x4"
- PIP008710 8"x6"x6"



**HEAVY DUTY WYE:**

- PIP008648 4"x3"x3"
- PIP008649 6"x3"x3"
- PIP008650 6"x4"x4"
- PIP008652 8"x4"x4"
- PIP008653 8"x6"x6"
- FIT020594 8"x4"x4"

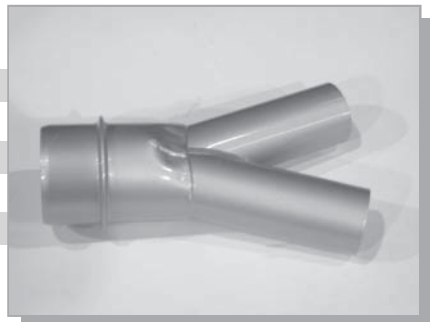

**HEAVY WALL PORTHOSE REDUCER:**

- CON001154 8" TO 6"
- CON020752 8" TO 6" (MALE TO MALE)



**FITTINGS & COUPLERS**

**QUICK ACTING HOSE COUPLING:**

(CAMLOCKS)

**ALUMINUM A SERIES MALE CAM TO F-NPT**

FIT005396	3/4"
FIT004025	1"
FIT004173	1-1/4"
FIT004366	1-1/2"
FIT020607	2"
FIT004842	2-1/2"
FIT004919	3"
FIT005017	4"
FIT005124	5"
FIT005217	6"
FIT005427	8" DIXON BRAND USED ON TRUCK (IMPORT)



**QUICK ACTING HOSE COUPLING:**

**ALUMINUM B SERIES F-CAM TO M-NPT**

FIT005400	3/4"
FIT004029	1"
FIT004177	1-1/4"
FIT004370	1-1/2"
FIT004700	2"
FIT004845	2-1/2"
FIT004924	3"
FIT005023	4"
FIT005127	5"
FIT005220	6"



**QUICK ACTING HOSE COUPLING:**

**ALUMINUM C SERIES F-CAM TO HOSE SHANK**

FIT005404	3/4"
HOS006719	1"
HOS006755	1-1/4"
HOS006772	1-1/2"
HOS006846	2"
HOS006885	2-1/2"
HOS006895	3"
FIT005027	4"
FIT005129	5"
FIT005223	6"



**QUICK ACTING HOSE COUPLING:**

**ALUMINUM D SERIES F-CAM TO F-NPT**

FIT005406	3/4"
FIT004034	1"
FIT004181	1-1/4"
FIT004374	1-1/2"
FIT004704	2"
FIT004848	2-1/2"
FIT004928	3"
FIT005029	4"
FIT005130	5"
FIT005224	6"



**QUICK ACTING HOSE COUPLING:**

**ALUMINUM E SERIES M-CAM TO HOSE SHANK**

FIT005418	3/4"
HOS006733	1"
HOS006759	1-1/4"
HOS006776	1-1/2"
HOS006850	2"
HOS	2-1/2"
HOS006899	3"
FIT005928	4"
FIT005137	5"
FIT005231	6"



**QUICK ACTING HOSE COUPLING:**

**ALUMINUM F SERIES M-CAM TO M-NPT**

FIT005420	3/4"
FIT004045	1"
FIT004193	1-1/4"
FIT004387	1-1/2"
FIT004716	2"
FIT0048857	2-1/2"
FIT004941	3"
FIT005045	4"
FIT005138	5"
FIT005232	6"

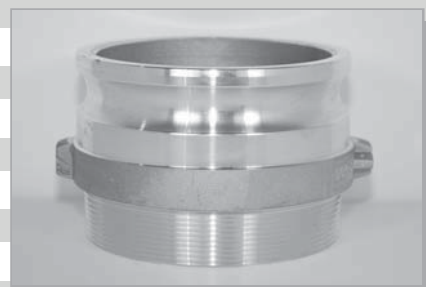

**QUICK ACTING HOSE COUPLING:****ALUMINUM DC SERIES DUST CAP**

FIT005408	3/4"
FIT004034	1"
FIT004138	1-1/4"
FIT004376	1-1/2"
FIT004706	2"
FIT004850	2-1/2"
FIT004930	3"
FIT005032	4"
FIT005930	6"
FIT005433	8" DIXON BRAND USED ON TRUCK (IMPORT)

**QUICK ACTING HOSE COUPLING:****ALUMINUM DP SERIES DUST PLUG**

FIT005412	3/4"
FIT004039	1"
FIT004187	1-1/4"
FIT004381	1-1/2"
FIT004710	2"
FIT004853	2-1/2"
FIT004935	3"
FIT005039	4"
FIT005134	5"
FIT005227	6"

**QUICK ACTING HOSE COUPLING:****BRASS D SERIES F-CAM TO F-NPT**

FIT005407	3/4"
FIT004034	1"
FIT004182	1-1/4"
FIT004375	1-1/2"
FIT004705	2"
FIT004845	2-1/2"
FIT004929	3"
FIT005031	4"
FIT005131	5"
FIT005225	6"



**QUICK ACTING HOSE COUPLING:****BRASS A SERIES M-CAM TO F-NPT**

FIT005397	3/4"
FIT004026	1"
FIT004174	1-1/4"
FIT004367	1-1/2"
FIT004697	2"
FIT04843	2-1/2"
FIT004920	3"
FIT005019	4"
FIT005125	5"
FIT005218	6"

**QUICK ACTING HOSE COUPLING:****BRASS B SERIES F-CAM TO M-NPT**

FIT005401	3/4"
FIT004030	1"
FIT004178	1-1/4"
FIT004371	1-1/2"
FIT004701	2"
FIT004846	2-1/2"
FIT004925	3"
FIT005024	4"
FIT005128	5"
FIT005221	6"

**QUICK ACTING HOSE COUPLING:****BRASS C SERIES F-CAM TO HOSE SHANK**

HOS007025	3/4"
HOS006720	1"
HOS006756	1-1/4"
HOS006773	1-1/2"
HOS006847	2"
HOS006886	2-1/2"
HOS006896	3"
HOS006930	4"
HOS006978	5"
HOS006989	6"





**QUICK ACTING HOSE COUPLING:****BRASS E SERIES M-CAM TO HOSE SHANK**

HOS007021	3/4"
HOS006734	1"
HOS006760	1-1/4"
HOS006777	1-1/2"
HOS006851	2"
HOS006888	2-1/2"
HOS006933	3"
HOS006933	4"
HOS006979	5"
HOS	6"

**QUICK ACTING HOSE COUPLING:****BRASS F SERIES M-CAM TO M-NPT**

FIT005421	3/4"
FIT004046	1"
FIT004194	1-1/4"
FIT004389	1-1/2"
FIT004717	2"
FIT004858	2-1/2"
FIT004943	3"
FIT005046	4"
FIT005139	5"
FIT005233	6"

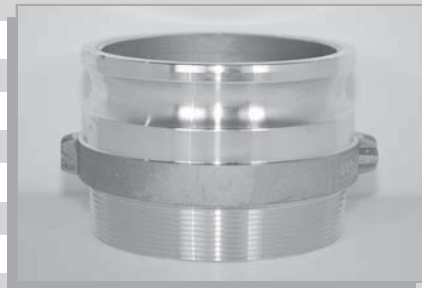
**QUICK ACTING HOSE COUPLING:****BRASS DC SERIES DUST CAP**

FIT005409	3/4"
FIT004036	1"
FIT004184	1-1/4"
FIT004378	1-1/2"
FIT004707	2"
FIT004851	2-1/2"
FIT004931	3"
FIT005034	4"
FIT005133	5"
FIT005226	6"



**QUICK ACTING HOSE COUPLING:**

**BRASS DP SERIES DUST PLUG**

FIT005413	3/4"
FIT004040	1"
FIT004188	1-1/4"
FIT004382	1-1/2"
FIT004711	2"
FIT004854	2-1/2"
FIT004936	3"
FIT005040	4"
FIT005135	5"
FIT005228	6"

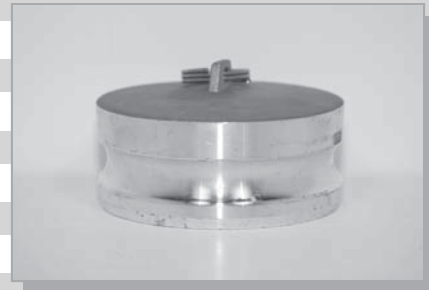

**QUICK ACTING HOSE COUPLING:**

**STAINLESS STEEL A SERIES M-CAM TO F-NPT**

FIT005399	3/4"
FIT004028	1"
FIT004176	1-1/4"
FIT004369	1-1/2"
FIT004699	2"
FIT004844	2-1/2"
FIT004923	3"
FIT005022	4"
FIT005126	5"
FIT005129	6"



**QUICK ACTING HOSE COUPLING:**

**STAINLESS STEEL B SERIES F-CAM TO M-NPT**

FIT005403	3/4"
FIT004032	1"
FIT004180	1-1/4"
FIT004373	1-1/2"
FIT004703	2"
FIT004847	2-1/2"
FIT004927	3"
FIT005026	4"
FIT005222	6"



**QUICK ACTING HOSE COUPLING:****STAINLESS STEEL C SERIES F-CAM TO HOSE SHANK**

HOS007027	3/4"
HOS006732	1"
HOS006758	1-1/4"
HOS006775	1-1/2"
HOS006849	2"
HOS006887	2-1/2"
HOS006898	3"
HOS006932	4"
HOS006990	6"

**QUICK ACTING HOSE COUPLING:****STAINLESS STEEL D SERIES F-CAM TO F-NPT**

FIT005417	3/4"
FIT004044	1"
FIT004192	1-1/4"
FIT004386	1-1/2"
FIT004715	2"
FIT004856	2-1/2"
FIT004940	3"
FIT005044	4"
FIT005136	5"
FIT005230	6"

**QUICK ACTING HOSE COUPLING:****STAINLESS STEEL E SERIES M-CAM TO HOSE SHANK**

HOS007031	3/4"
HOS006736	1"
HOS006762	1-1/4"
HOS006779	1-1/2"
HOS006853	2"
HOS006889	2-1/2"
HOS006910	3"
HOS006935	4"
HOS006991	6"



**QUICK ACTING HOSE COUPLING:**

**STAINLESS STEEL F SERIES M-CAM TO M-NPT**

FIT005423	3/4"
FIT004048	1"
FIT004196	1-1/4"
FIT004391	1-1/2"
FIT004719	2"
FIT004859	2-1/2"
FIT004945	3"
FIT005049	4"
FIT005234	6"



**QUICK ACTING HOSE COUPLING:**

**STAINLESS STEEL DC SERIES DUST CAP**

FIT005411	3/4"
FIT004038	1"
FIT004186	1-1/4"
FIT004380	1-1/2"
FIT004709	2"
FIT004852	2-1/2"
FIT004934	3"
FIT005038	4"
FIT008359	6"



**QUICK ACTING HOSE COUPLING:**

**STAINLESS STEEL DP SERIES DUST PLUG**

FIT005416	3/4"
FIT004043	1"
FIT004191	1-1/4"
FIT004385	1-1/2"
FIT004714	2"
FIT004855	2-1/2"
FIT004939	3"
FIT005043	4"
FIT005229	6"



**REDUCERS:****ALUMINUM F-CAM TO M-CAM**

FIT004740	2" TO 3"
FIT004947	3" TO 2"
FIT005050	4" TO 2"
FIT005929	4" TO 3"
FIT005237	6" TO 4"

**BRASS F-CAM TO M-CAM**

FIT004741	2" TO 3"
FIT004948	3" TO 2"
FIT005051	4" TO 2"
FIT005053	4" TO 3"

**STAINLESS STEEL F-CAM TO M-CAM**

FIT004950	2" TO 3"
FIT005054	4" TO 3"
FIT005239	6" TO 4"

**HOSE COUPLING HANDLES & PINS:****STAINLESS STEEL REPLACEMENT PIECES**

FAS002599	3/4"
FAS002630	1"-1-1/4"
FAS002660	1-1/2"-2-1/2"
FAS002700	3"-5"
FAS002732	6"-8"

**BRASS REPLACEMENT PIECES**

FAS002659	2"
FAS002699	3"
FAS005235	6"

**HOSE COUPLING GASKETS:****ALUMINUM HOSE COUPLING REPLACEMENT BUNA GASKETS**

GAS006261	3/4"
GAS006122	1"
GAS006144	1-1/4"
GAS006147	1-1/2"
GAS006163	2"
GAS006186	2-1/2"
GAS006204	3"
GAS006230	4"
GAS006243	5"
GAS006254	6"



**COMBINATION HOSE NIPPLES:****PLAIN STEEL**

STN050	1/2"
STN075	3/4"
STN100	1"
STN125	1-1/4"
STN150	1-1/2"
STN200	2"
STN250	2-1/2"
STN300	3"
STN400	4"
STN500	5"
STN600	6"

**PLATED STEEL**

SPN050	1/2"
SPN075	3/4"
SPN100	1"
SPN125	1-1/4"
SPN150	1-1/2"
SPN200	2"
SPN250	2-1/2"
SPN300	3"
SPN400	4"
SPN500	5"
SPN600	6"

**SPIRAL DOUBLE BOLT CLAMP:****FOR TIGERFLEX HOSE**

CLA022301	2"
CLA000984	3"
CLA000985	4"
CLA000986	5"
CLA000987	6"
CLA000988	8"
CLA000980	10"
CLA000981	12"

**POWER LOCK CLAMP:****FOR KANAFLEX HOSE**

CLA000963	2"
CLA000964	3"
CLA000965	4"
CLA000966	5"
CLA000967	6"
CLA000968	8"
CLA000961	10"
CLA000962	12"



## DOUBLE BOLT CLAMP:

CLA000840	4-1/16"-4-5/8"
CLA000842	4-11/16"-5-1/4"
CLA000843	5"-5-1/2"
CLA000911	5-1/16"-6-1/16"
CLA000845	6-1/8"-6-7/8"
CLA000846	6-15/16"-7-5/8"
CLA000847	7-11/16"-8-3/16"
CLA000924	8-1/4"-8-7/8"
CLA000849	8-15/16"-9-7/8"

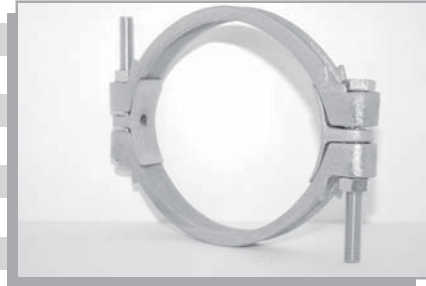

This page left intentionally blank



**GapVax<sup>®</sup>**

**SECTION D:  
BOOM ACCESSORIES & PARTS/  
FILTER BAGS & CAGES**

## TOOLBOXES:

- BOX00810 POLISHED ALUMINUM (SIZE: 24"x24"x30")
- BOX00812 STEEL (SIZE: 24"x24"x30")
- AO11267 LEFT MOUNTING BRACKET
- AO11268 RIGHT MOUNTING BRACKET

## LOAD INDICATORS:

### FLOAT BALL LOAD LEVEL INDICATOR:

- GAU006470 SHORT STEM INDICATOR W/STAINLESS STEEL BALL
- GAU006469 LONG STEM LEVEL INDICATOR W/STAINLESS STEEL BALL
- GAU006468 LEVEL INDICATOR W/6" PLASTIC BALL

### REPLACEMENT PARTS:

- GAU006469 INDICATOR ARROW
- GAU006132 VITON SEALING GASKET ON TANK
- GAU006466 6" FOAM FILLED PLASTIC BALL
- GAU006464 6" STAINLESS STEEL BALL
- GAU006471 FLOAT PIVOT WELDMENT
- GAU006134 VITON O-RINGS (2 REQUIRED)



## FLOAT BALLS:

### STAINLESS STEEL FLOAT BALL (NO HOLE):

- VAL012041 3"
- VAL01204 4"
- VAL012043 6"
- VAL012044 8"
- VAL012086 10"
- VAL012008 12"



## RUBBER ISOLATION MOUNTS:

- CON001134 TRANSFER CASE MOUNTS
- PUM009246 HIBON BLOWER MOUNTS
- CON001135 ROOTS BLOWER MOUNTS



**BAND BRAKE & AIR CYLINDER:**

- AO10357 BOOM BAND BRAKE
- CYL001221 AIR CYLINDER
- DRI001299 YOKE FOR AIR CYLINDER
- PW-2.1 PUMP FOR KFS3573
- TNK020720 RESERVOIR FOR KFS3573
- MOT022303 MOTOR FOR KFS3573

**BOOM POWER PACK:**

- ELE001646 BOOM POWER PACK
- ELE001916 EXTENDABLE BOOM POWER PACK
- ELE001726 REPLACEMENT SOLENOID

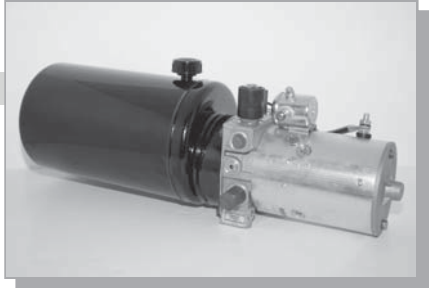

**HEAVY-DUTY GROUND CABLE:**

- ELE001905 25' GROUND CABLE
- ELE0019060 50' GROUND CABLE

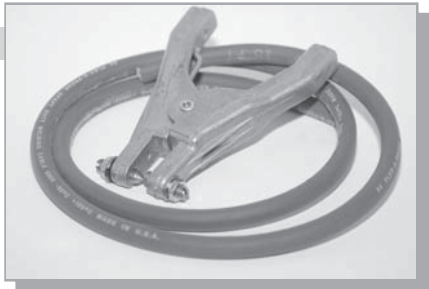

**FILTER BAGS:**

**POLYESTER (TEMP 285 DEG F)**

- FIL003544 40"
- FIL003545 50"
- FIL003546 60"
- FIL003547 68"

**POLYPROPYLENE (TEMP 195 DEG F)**

- FIL003517 40"
- FIL003556 60"
- FIL003519 68"

**NOMEX (TEMP 400 DEG F)**

- FIL003520 40"
- FIL003521 60"
- FIL003522 68"

**ULTRA HIGH EFFICIENCY (TEMP 285 DEG F)**

- FIL003523 40"
- FIL003462 60"
- FIL003525 68"



**FILTER CAGES:****LOW VAC**

FIL003426	40" STEEL
FIL003429	50" STEEL
FIL003432	60" STEEL
FIL003435	68" STEEL
FIL003427	40" GALVANIZED STEEL
FIL003430	50" GALVANIZED STEEL
FIL003433	60" GALVANIZED STEEL
FIL003436	68" GALVANIZED STEEL
FIL003428	40" STAINLESS STEEL
FIL003431	50" STAINLESS STEEL
FIL003434	60" STAINLESS STEEL
FIL003437	68" STAINLESS STEEL

**HI-VAC**

CAT00828	40" STEEL
FIL003440	50" STEEL
FIL003443	60" STEEL
FIL003446	68" STEEL
FIL003438	40" GALVANIZED STEEL
FIL003441	50" GALVANIZED STEEL
FIL003444	60" GALVANIZED STEEL
FIL003447	68" GALVANIZED STEEL
FIL003439	40" STAINLESS STEEL
FIL003442	50" STAINLESS STEEL
FIL003445	60" STAINLESS STEEL
FIL003448	68" STAINLESS STEEL



This page left intentionally blank

**GapVax<sup>®</sup>**

**SECTION E:  
NOZZLES/TRIGGER GUNS, LANCES,  
REGULATORS & SEWER CLEANING  
EQUIPMENT**

**NOZZLES****BULK NOZZLE W/RINGLOCK:**

NOZ007945	3" ALUMINUM
NOZ007949	4" ALUMINUM
NOZ007953	6" ALUMINUM
NOZ007947	3" STEEL
NOZ007951	4" STEEL
NOZ007955	6" STEEL

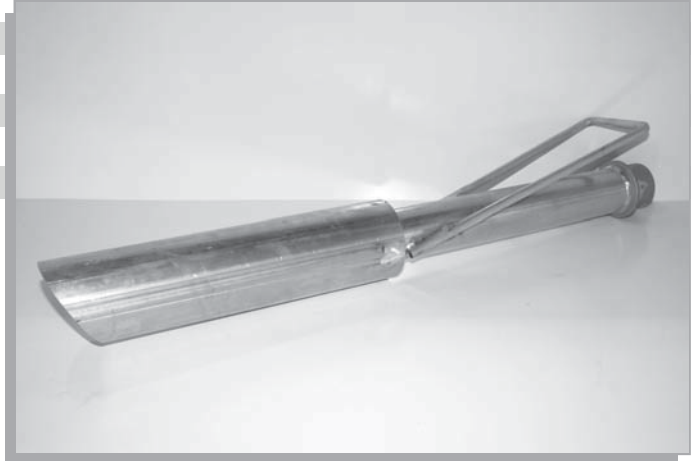
**BULK NOZZLE W/CAMLOCK:**

NOZ007946	3" ALUMINUM
NOZ007950	4" ALUMINUM
NOZ007954	6" ALUMINUM
NOZ007948	3" STEEL
NOZ007952	4" STEEL
NOZ007956	6" STEEL

**DUCKBILL NOZZLE W/RINGLOCK:**

NOZ008013	3" ALUMINUM
NOZ008017	4" ALUMINUM
NOZ008021	6" ALUMINUM
NOZ008015	3" STEEL
NOZ008019	4" STEEL
NOZ008023	6" STEEL



**DUCKBILL NOZZLE W/CAMLOCK:**

DBNOZ03AL-C	3" ALUMINUM
DBNOZ04AL-C	4" ALUMINUM
DBNOZ06AL-C	6" ALUMINUM
DBNOZ03ST-C	3" STEEL
DBNOZ04ST-C	4" STEEL
DBNOZ06ST-C	6" STEEL

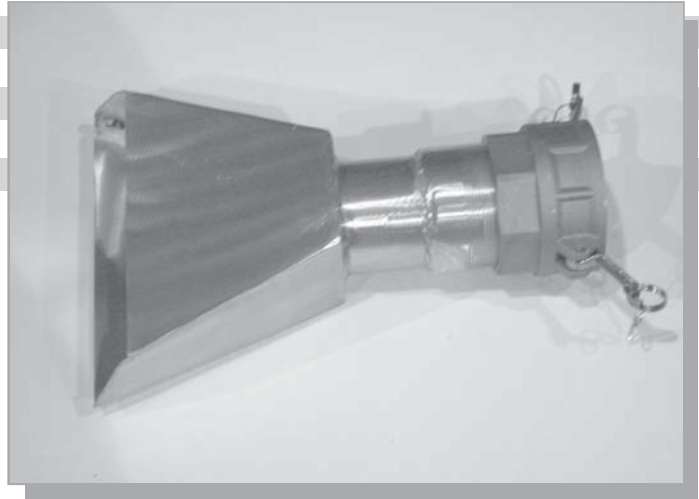
**CROWN NOZZLE:**

CNOZ04AL-3	4"x3'
CNOZ04AL-4	4"x4'
CNOZ04AL-5	4"x5'
CNOZ04AL-6	4"x6'
CNOZ04ST-3	4"x3'
CNOZ04ST-4	4"x4'
CNOZ04ST-5	4"x5'
CNOZ04ST-6	4"x6'
CNOZ06AL-3	6"x3'
CNOZ06AL-4	6"x4'
CNOZ06AL-5	6"x5'
CNOZ06AL-6	6"x6'
CNOZ06ST-3	6"x3'
CNOZ06ST-4	6"x4'
CNOZ06ST-5	6"x5'
CNOZ06ST-6	6"x6'
CNOZ08AL-3	8"x3'
CNOZ08AL-4	8"x4'
CNOZ08AL-5	8"x5'
CNOZ08AL-6	8"x6'
CNOZ08ST-3	8"x3'
CNOZ08ST-4	8"x4'
CNOZ08ST-5	8"x5'
CNOZ08ST-6	8"x6'

**NOTE:**

AL = ALUMINUM

ST = STEEL



**NOZZLES****CROWN NOZZLE W/WATERJETS:**

CNOZ06ALWJ-3	6"x3'
CNOZ06ALWJ-4	6"x4'
CNOZ06ALWJ-5	6"x5'
CNOZ06ALWJ-6	6"x6'
CNOZ06STWJ-3	6"x3'
CNOZ06STWJ-4	6"x4'
CNOZ06STWJ-5	6"x5'
CNOZ06STWJ-6	6"x6'
CNOZ08ALWJ-3	8"x3'
CNOZ08ALWJ-4	8"x4'
CNOZ08ALWJ-5	8"x5'
CNOZ08ALWJ-6	8"x6'
CNOZ08STWJ-3	8"x3'
CNOZ08STWJ-4	8"x4'
CNOZ08STWJ-5	8"x5'
CNOZ08STWJ-6	8"x6'

**NOTE:**

AL = ALUMINUM

ST = STEEL

**FLOOR NOZZLE W/RINGLOCK:**

FNOZ03AL	3" ALUMINUM
FNOZ04AL	4" ALUMINUM
FNOZ06AL	6" ALUMINUM
FNOZ03ST	3" STEEL
FNOZ04ST	4" STEEL
FNOZ06ST	6" STEEL

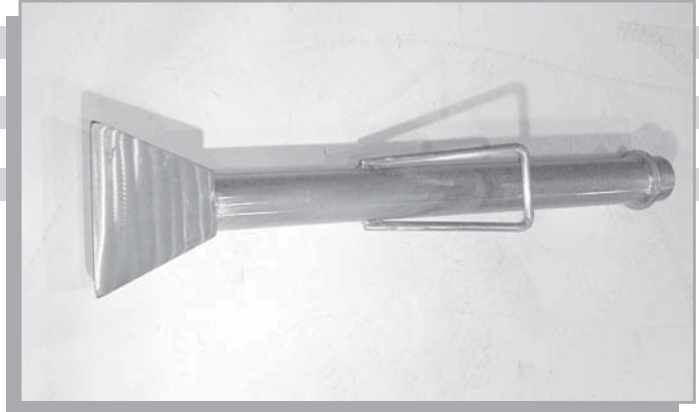
**FLOOR NOZZLE W/CAMLOCK:**

FNOZ03AL-C	3" ALUMINUM
FNOZ04AL-C	4" ALUMINUM
FNOZ06AL-C	6" ALUMINUM
FNOZ03ST-C	3" STEEL
FNOZ04ST-C	4" STEEL
FNOZ06ST-C	6" STEEL



**LOW PROFILE FLOOR NOZZLE W/RINGLOCK:**

- LPFNOZ03AL 3" ALUMINUM
- LPFNOZ04AL 4" ALUMINUM
- LPFNOZ06AL 6" ALUMINUM
- LPFNOZ03ST 3" STEEL
- LPFNOZ04ST 4" STEEL
- LPFNOZ06ST 6" STEEL

**NOTE:** OPTIONAL STEEL OR ALUMINUM NOZZLE W/WHEEL



**LOW PROFILE FLOOR NOZZLE W/CAMLOCK:**

- LPFNOZ03AL-C 3" ALUMINUM
- LPFNOZ04AL-C 4" ALUMINUM
- LPFNOZ06AL-C 6" ALUMINUM
- LPFNOZ03ST-C 3" STEEL
- LPFNOZ04ST-C 4" STEEL
- LPFNOZ06ST-C 6" STEEL

**NOTE:** OPTIONAL STEEL OR ALUMINUM NOZZLE W/WHEEL



**PRODUCTION NOZZLE W/RINGLOCK:**

- PNOZ03AL 3" ALUMINUM
- PNOZ04AL 4" ALUMINUM
- PNOZ06AL 6" ALUMINUM
- PNOZ03ST 3" STEEL
- PNOZ04ST 4" STEEL
- PNOZ06ST 6" STEEL

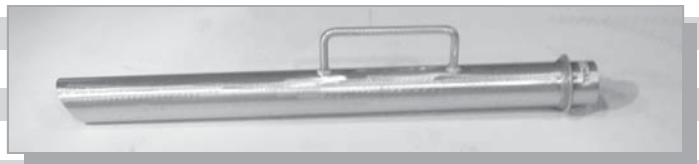

**PRODUCTION NOZZLE W/CAMLOCK:**

- PNOZ03AL-C 3" ALUMINUM
- PNOZ04AL-C 4" ALUMINUM
- PNOZ06AL-C 6" ALUMINUM
- PNOZ03ST-C 3" STEEL
- PNOZ04ST-C 4" STEEL
- PNOZ06ST-C 6" STEEL

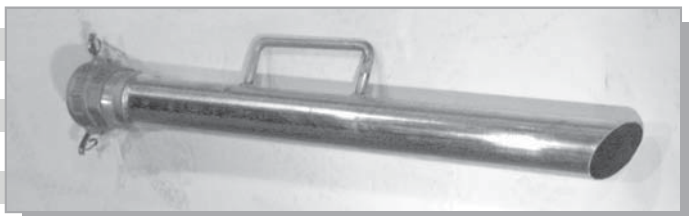

**NOZZLES**

**WATER JET FLOOR NOZZLE:**

WJFNOZ03AL	3" ALUMINUM
WJFNOZ03ST	3" STEEL
WJFNOZ04AL	4" ALUMINUM
WJFNOZ04ST	4" STEEL
WJFNOZ06AL	6" ALUMINUM
WJFNOZ06ST	6" STEEL

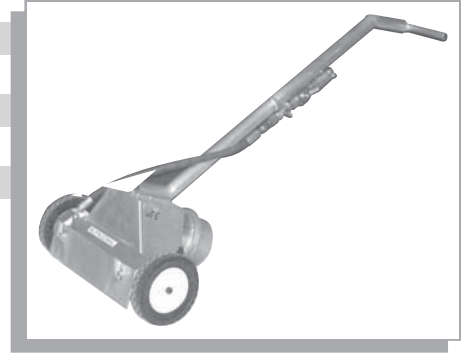

**ROOF ROCK NOZZLE:**

NOZ008089	6" STEEL
-----------	----------



**22040B SERIES ROTATING NOZZLE:**

MODEL NUMBER	NAME	SIZE	PSI	TEMP.	INLET SIZE	WEIGHT
22040B-2.0	TURBO LASER	2.0	3600	212°F	1/4FNPT	0.7 LBS.
22040B-3.5	TURBO LASER	3.5	3600	212°F	1/4FNPT	0.7 LBS.
22040B-4.0	TURBO LASER	4.0	3600	212°F	1/4FNPT	0.7 LBS.
22040B-4.5	TURBO LASER	4.5	3600	212°F	1/4FNPT	0.7 LBS.
22040B-5.0	TURBO LASER	5.0	3600	212°F	1/4FNPT	0.7 LBS.
22040B-5.5	TURBO LASER	5.5	3600	212°F	1/4FNPT	0.7 LBS.
22040B-6.0	TURBO LASER	6.0	3600	212°F	1/4FNPT	0.7 LBS.
22040B-8.0	TURBO LASER	8.0	3600	212°F	1/4FNPT	0.7 LBS.
22040B-10.0	TURBO LASER	10	3600	212°F	1/4FNPT	0.7 LBS.



**22060A SERIES ROTATING NOZZLE:**

MODEL NUMBER	NAME	SIZE	PSI	TEMP.	INLET SIZE	WEIGHT
22060A-2.0	TURBO LASER	2.0	5100	212°F	1/4FNPT	1.8 LBS.
22060A-3.0	TURBO LASER	3.0	5100	212°F	1/4FNPT	1.8 LBS.
22060A-3.5	TURBO LASER	3.5	5100	212°F	1/4FNPT	1.8 LBS.
22060A-4.0	TURBO LASER	4.0	5100	212°F	1/4FNPT	1.8 LBS.
22060A-4.5	TURBO LASER	4.5	5100	212°F	1/4FNPT	1.8 LBS.
22060A-5.0	TURBO LASER	5.0	5100	212°F	1/4FNPT	1.8 LBS.
22060A-5.5	TURBO LASER	5.5	5100	212°F	1/4FNPT	1.8 LBS.
22060A-6.0	TURBO LASER	6.0	5100	212°F	1/4FNPT	1.8 LBS.
22060A-7.0	TURBO LASER	7.0	5100	212°F	1/4FNPT	1.8 LBS.
22060A-8.0	TURBO LASER	8.0	5100	212°F	1/4FNPT	1.8 LBS.
22060A-12.0	TURBO LASER	12	5100	212°F	1/4FNPT	1.8 LBS.

**22400 SERIES ROTATING NOZZLE:**

MODEL NUMBER	NAME	SIZE	PSI	TEMP.	INLET SIZE	WEIGHT
22400-35	TURBO LASER	3.5	7250	212°F	1/4FNPT	1.8 LBS.
22400-40	TURBO LASER	4.0	7250	212°F	1/4FNPT	1.8 LBS.
22400-45	TURBO LASER	4.5	7250	212°F	1/4FNPT	1.8 LBS.
22400-50	TURBO LASER	5.0	7250	212°F	1/4FNPT	1.8 LBS.
22400-55	TURBO LASER	5.5	7250	212°F	1/4FNPT	1.8 LBS.
22400-80	TURBO LASER	8.0	7250	212°F	1/4FNPT	1.8 LBS.



## 22700 SERIES OSCILLATING NOZZLE:

MODEL NUMBER	NAME	SIZE	PSI	TEMP.	INLET SIZE	WEIGHT
22700-30	TURBO LASER	3.0	7250	212°F	1/4FNPT	1.4 LBS.
22700-35	TURBO LASER	3.5	7250	212°F	1/4FNPT	1.4 LBS.
22700-40	TURBO LASER	4.0	7250	212°F	1/4FNPT	1.4 LBS.
22700-45	TURBO LASER	4.5	7250	212°F	1/4FNPT	1.4 LBS.
22700-50	TURBO LASER	5.0	7250	212°F	1/4FNPT	1.4 LBS.
22700-55	TURBO LASER	5.5	7250	212°F	1/4FNPT	1.4 LBS.



BROWN COVER

## FILTER (5100 PSI):

MODEL NUMBER	DESCRIPTION	WEIGHT
22175	1/4" MNPT x 1/4" FNPT TURBO FILTER (100 MESH)	0.3 LBS.



**GIANT TURBO NOZZLE-REPAIR KITS:****22040B REPAIR KITS:****KIT# NOZZLE**

9440A-2.0 #2.0

9440A-3.5 #3.5

9440A-4.0 #4.0

9440A-4.5 #4.5

9440A-5.0 #5.0

9440A-5.5 #5.5

9440A-6.0 #6.0

9440A-8.0 #8.0

9440A-10 #10

**22060A REPAIR KITS:****KIT# NOZZLE**

9240A-20 #2.0

9240A-30 #3.0

9240A-35 #3.5

9240A-40 #4.0

9240A-45 #4.5

9240A-50 #5.5

9240A-55 #5.5

9240A-60 #6.0

9240A-70 #7.0

9240A-80 #8.0

9240A-12.0 #12.0

**22400 REPAIR KITS:****KIT# NOZZLE**

09481 #3.5

09488 #4.0

09482 #4.5

09483 #5.0

09484 #5.5

09489 #8.0

**22700 REPAIR KITS:****KIT# NOZZLE**

9469 #3.0

9470 #3.5

9471 #4.0

9472 #4.5

9473 #5.0

9474 #5.5

**STANDARD ROUND HEAD RADIAL NOZZLE:**

	SIZE	FLOW RATE	ANGLE OF REAR JETS	TYPE OF FRONT JET	ESTIMATED WORKING DIAMETER
5520.30	1/2"	20-25 GPM	35 DEGREES	ORIFICE M6X8	2"-8"
5520.60	3/4"	35-40 GPM	35 DEGREES	ORIFICE M6X8	3.5"-10"
5520.70	1"	80 GPM	35 DEGREES	ORIFICE M6X8	4"-14"

**NOTE:** OTHER SIZES AVAILABLE UPON REQUEST

**NOTE:** TO OPTIMIZE CLEANING PERFORMANCE, PROVIDE THE FOLLOWING:

- A) SYSTEM FLOW (WORKING GPM OF PUMP)
- B) SYSTEM PRESSURE (WORKING PSI OF PUMP)
- C) HOSE SIZE, TYPE & LENGTH

**APPLICATIONS:** DRAINS, SMALL PIPES (W/LIMESTONE, SOAP AND GREASE BUILD-UP), GENERAL PIPE CLEANING APPLICATIONS



**THRUST RADIAL LIVENZA NOZZLE:**

	SIZE	FLOW RATE	ANGLE OF REAR JETS	TYPE OF FRONT JET	ESTIMATED WORKING DIAMETER
5515.30	1/2"	20-25 GPM	15 DEGREES	ORIFICE M6X8	2"-8"
5515.60	3/4"	35-40 GPM	15 DEGREES	ORIFICE M6X8	3.5"-12"
5515.70	1"	80 GPM	15 DEGREES	ORIFICE M6X8	4"-14"

**NOTE:** OTHER SIZES AVAILABLE UPON REQUEST

**NOTE:** TO OPTIMIZE CLEANING PERFORMANCE, PROVIDE THE FOLLOWING:

- A) SYSTEM FLOW (WORKING GPM OF PUMP)
- B) SYSTEM PRESSURE (WORKING PSI OF PUMP)
- C) HOSE SIZE, TYPE & LENGTH

**APPLICATIONS:** DRAINS, HIGH COLUMNS



**COMBINED JET ANGLES NOZZLE:**

	SIZE	FLOW RATE	ANGLE OF REAR JETS	TYPE OF FRONT JET	ESTIMATED WORKING DIAMETER
5528.50	1/2"	20-25 GPM	15 + 30 DEG.	ORIFICE M6X8	2"-6"
5532.50	3/4"	35-40 GPM	15 + 30 DEG.	ORIFICE M6X8	3.5"-12"
5533.50	1"	80 GPM	15 + 30 DEG.	ORIFICE M6X8	4"-16"

**NOTE:** OTHER SIZES AVAILABLE UPON REQUEST

**NOTE:** TO OPTIMIZE CLEANING PERFORMANCE, PROVIDE THE FOLLOWING:

- A) SYSTEM FLOW (WORKING GPM OF PUMP)
- B) SYSTEM PRESSURE (WORKING PSI OF PUMP)
- C) HOSE SIZE, TYPE & LENGTH

**APPLICATIONS:** CLEANING OF PIPES (W/ACCUMULATION OF GREASE & SOAP BUILD-UP), DRAINS & HIGH COLUMNS, EASY TURN IN A SHARP ELBOW, EASY RETRIEVAL FROM PIPE

**RONDO FAN-JET GREASE REMOVER NOZZLE:**

	SIZE	FLOW RATE	ANGLE OF REAR JETS	TYPE OF FRONT JET	ESTIMATED WORKING DIAMETER
3580.01	1/2"	20-25 GPM	18 + 45 DEG.	(3) M6X8 ORIFICES (6) FAN-JETS	2"-8"
3580.05	3/4"	35-40 GPM	18 + 45 DEG.	(3) M6X8 ORIFICES (8) FAN-JETS	2.5"-14"
3580.10	1"	60-65 GPM	18 + 45 DEG.	(3) M6X8 ORIFICES (9) FAN-JETS	3"-18"





**NOZZLES**

**ARZINO NOZZLE:**

	SIZE	FLOW RATE	ANGLE OF REAR JETS	TYPE OF FRONT JET	ESTIMATED WORKING DIAMETER
5528.06	1/2"	20-25 GPM	15 DEGREES	ORIFICE M6X8 FRONT & REAR	2.5"-8"
5532.06	3/4"	35-40 GPM	15 DEGREES	ORIFICE M6X8 FRONT & REAR	4"-10"
5533.06	1"	60-65 GPM	15 DEGREES	ORIFICE M6X8 FRONT & REAR	6"-14"

**NOTE:** OTHER SIZES AVAILABLE UPON REQUEST  
**NOTE:** TO OPTIMIZE CLEANING PERFORMANCE, PROVIDE THE FOLLOWING:  
**A)** SYSTEM FLOW (WORKING GPM OF PUMP)  
**B)** SYSTEM PRESSURE (WORKING PSI OF PUMP)  
**C)** HOSE SIZE, TYPE & LENGTH

**APPLICATIONS:** CLEANING OF PIPES (WHERE HIGH THRUST IS REQUIRED), PIPES WITH SHARP TURNS AND/OR HEAVY BUILD-UP



**TRI-HEAD PENETRATOR NOZZLE:**

	SIZE	FLOW RATE	ANGLE OF REAR JETS	TYPE OF FRONT JET	ESTIMATED WORKING DIAMETER
5550.10	1/2"	20-25 GPM	25 DEGREES	DRILLED REAR 1@0°+ 3@15° M4X5 FRONT	2"-6"
5550.20	3/4"	35-40 GPM	25 DEGREES	ORIFICE M6X8 REAR 1@0°+ 3@15° FRONT	4"-10"
5550.30	1"	60-65 GPM	25 DEGREES	ORIFICE M6X8 REAR 1@0°+ 3@15° FRONT	6"-14"

**NOTE:** OTHER SIZES AVAILABLE UPON REQUEST  
**NOTE:** TO OPTIMIZE CLEANING PERFORMANCE, PROVIDE THE FOLLOWING:  
**A)** SYSTEM FLOW (WORKING GPM OF PUMP)  
**B)** SYSTEM PRESSURE (WORKING PSI OF PUMP)  
**C)** HOSE SIZE, TYPE & LENGTH

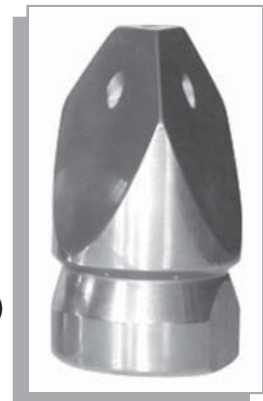

**HIGH EFFICIENCY NOZZLE:**

	SIZE	FLOW RATE	ANGLE OF REAR JETS	TYPE OF FRONT JET	ESTIMATED WORKING DIAMETER
65540.60 (FARA)	1"	60-65 GPM	(8)@ 15 DEG.	ORIFICE 1/4 TE REAR ORIFICE M10X16 FRONT	6"-16"
65540.70 (CANIN)	1"	60-65 GPM	(4)@ 5 DEG.+ (4)@ 10 DEG.	ORIFICE 1/4 TE REAR	6"-20"
65540.80 (DURANO)	1-1/4"	80-90 GPM	(6)@ 20 DEG.+ (6)@ 30 DEG.	ORIFICE 1/4 TE REAR ORIFICE M10X16 FRONT	12"-32"

**NOTE:** OTHER SIZES AVAILABLE UPON REQUEST

**FLAT CULVERT NOZZLE:**

	SIZE	FLOW RATE	ANGLE OF REAR JETS	TYPE OF FRONT JET	ESTIMATED WORKING DIAMETER
65500.86	1"	60-65 GPM	(6)@ 15 DEG.	ORIFICE 1/4 TE	16"-120"
65500.88	1/2"	20-25 GPM	(6)@ 10 DEG.	ORIFICE M6X8	4"-14"

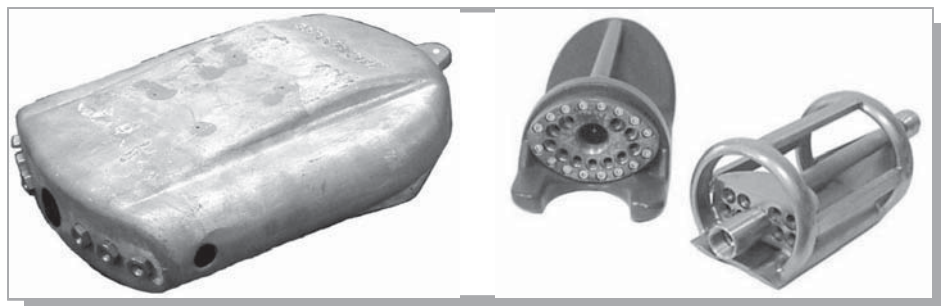
**SAND & SLUDGE NOZZLE:**

35E	4" DIAMETER x 5" LONG	3/4" HOSE
35F	4-1/2" DIAMETER x 6" LONG	1" HOSE

**NOTE:** OTHER SIZES AVAILABLE UPON REQUEST

**NOTE:** TO OPTIMIZE CLEANING PERFORMANCE, PROVIDE THE FOLLOWING:

- A) INDICATE HOSE SIZE
- B) PROVIDE DESIRED FLOW RATE
- C) INDICATE DESIRED PRESSURE (PSI)

**REPLACEMENT NOZZLE TIPS:**

INTERCHANGEABLE ORIFICES

**ORIFICE DIAMETER (MM)**

BLIND	M4X5
0.60	85990.00
0.80	85990.060
1.00	85990.10
1.20	85990.12
1.30	
1.40	85990.14
1.50	
1.60	85990.16
1.80	85990.18

**ORIFICE DIAMETER (MM)**

BLIND	M6X8
0.60	85992.00
0.80	85992.060
1.00	85992.10
1.20	85992.12
1.30	
1.40	85992.14
1.50	
1.60	85992.16
1.80	85992.18
2.00	85992.20
2.20	85992.22
2.25	
2.40	85992.24
2.60	85992.26
2.80	85992.28

**ORIFICE DIAMETER (MM) M6X8 W/CERAMIC**

BLIND	85990.00
0.60	85993.006
0.80	85993.008
1.00	85993.010
1.20	85993.012
1.30	
1.40	
1.50	85993.015
1.60	
1.80	85993.018
2.00	85993.020
2.20	85993.022
2.25	85993.024

**ORIFICE DIAMETER (MM) M8X8 W/CERAMIC**

BLIND	8105.03
0.60	85994.060
0.80	85994.080
1.00	85994.010
1.20	85993.012

**NOZZLES**

ORIFICE DIAMETER (MM) M8X8 W/CERAMIC, CONT'D.	
1.30	
1.40	
1.50	85994.15
1.60	
1.80	85994.18
2.00	85994.20
2.20	85994.22
2.25	85994.24

ORIFICE DIAMETER (MM) TE 1/4" M W/CERAMIC	
BLIND	85506.400
0.60	
0.80	
1.00	
1.20	
1.30	85506.803
1.40	
1.50	
1.60	85506.806
1.80	85506.808
2.00	85506.810
2.20	85506.812
2.25	
2.40	85506.814
2.60	85506.816
2.80	85506.818
3.00	85506.820
3.10	85506.821
3.30	85506.823

**TRIGGER GUNS**

**ST1500 TRIGGER GUN:**

- ◆ 12 GPM MAXIMUM FLOW
- ◆ 4,000 PSI MAXIMUM PRESSURE
- ◆ 300°F MAXIMUM TEMPERATURE
- ◆ 3/8" FPT INLET x 1/4" FPT OUTLET
- ◆ 20.5 OZ. WEIGHT

163	ST1500
22325	ST1500 W/WEEP
227	UNITIZED VALVE



**TRIGGER GUNS****ST2300 EASY PULL GUN:**

- ◆ REPLACES ST1600
  - ◆ 12 GPM MAXIMUM FLOW
  - ◆ 4,500 PSI MAXIMUM PRESSURE
  - ◆ 300°F MAXIMUM TEMPERATURE
  - ◆ 3/8" FPT INLET x 1/4" FPT OUTLET
  - ◆ 21.0 OZ. WEIGHT
- |           |                |
|-----------|----------------|
| TLS020736 | ST2300         |
| 25080     | ST2300 W/WEEP  |
| 25081     | UNITIZED VALVE |

**ST2000 TRIGGER GUN:**

- ◆ 12 GPM MAXIMUM FLOW
  - ◆ 4,000 PSI MAXIMUM PRESSURE
  - ◆ 300°F MAXIMUM TEMPERATURE
  - ◆ 3/8" FPT INLET x 1/4" FPT OUTLET
  - ◆ 26.0 OZ. WEIGHT
- |     |                |
|-----|----------------|
| 165 | ST2000         |
| 227 | UNITIZED VALVE |

**ST601 TRIGGER GUN:**

- ◆ 12 GPM MAXIMUM FLOW
  - ◆ 4,000 PSI MAXIMUM PRESSURE
  - ◆ 300°F MAXIMUM TEMPERATURE
  - ◆ 3/8" FPT INLET x 1/4" FPT OUTLET
  - ◆ 23.0 OZ. WEIGHT
- |     |                |
|-----|----------------|
| 159 | ST601          |
| 227 | UNITIZED VALVE |



**ST1100 TRIGGER GUN:**

- ◆ 7 GPM MAXIMUM FLOW
- ◆ 3,000 PSI MAXIMUM PRESSURE
- ◆ 300°F MAXIMUM TEMPERATURE
- ◆ 3/8" FPT INLET x 1/4" FPT OUTLET
- ◆ 15.0 OZ. WEIGHT

SU1100	ST1100
21023	REPAIR KIT



**YG5000 TRIGGER GUN:**

- ◆ 8 GPM MAXIMUM FLOW
- ◆ 5,000 PSI MAXIMUM PRESSURE
- ◆ 320°F MAXIMUM TEMPERATURE
- ◆ 3/8" FPT INLET x 1/4" FPT OUTLET
- ◆ 28.5 OZ. WEIGHT

3807	YG5000
225	VALVE



**ST2600 RELAXED ACTION GUN:**

- ◆ 12 GPM MAXIMUM FLOW
- ◆ 4,500 PSI MAXIMUM PRESSURE
- ◆ 300°F MAXIMUM TEMPERATURE
- ◆ 3/8" FPT INLET x 1/4" FPT OUTLET
- ◆ 21.0 OZ. WEIGHT

TLS020735	ST2600
25081	UNITIZED VALVE



**TRIGGER GUNS**

**YG4060 STAINLESS GUN:**

- ◆ CORROSION RESISTANCE
  - ◆ ALL WETTED PARTS ARE STAINLESS STEEL
  - ◆ CHEMICAL AND TEMPERATURE-RESISTANT SEALS
  - ◆ 10.5 GPM MAXIMUM FLOW
  - ◆ 4,000 PSI MAXIMUM PRESSURE
  - ◆ 300°F MAXIMUM TEMPERATURE
  - ◆ 3/8" FPT INLET x 1/4" FPT OUTLET
  - ◆ 27.0 OZ. WEIGHT
- NOZ007834 303 STAINLESS  
 NOZ007828 VALVE KIT



**GIANT TRIGGER GUN:**

- REINFORCED PLASTIC HANDLE
- ◆ BRASS VALVE HOUSING
  - ◆ STAINLESS STEEL OUTLET TUBE
  - ◆ 10 GPM MAXIMUM FLOW
  - ◆ 5,000 PSI MAXIMUM PRESSURE
  - ◆ 300°F MAXIMUM TEMPERATURE
  - ◆ 3/8" FPT INLET x 1/4" FPT OUTLET
  - ◆ 28.0 OZ. WEIGHT
- NOZ007870 MODEL 21250B  
 40045 REPAIR KIT  
 21277 REBUILD KIT  
 21251 BIG SPRING

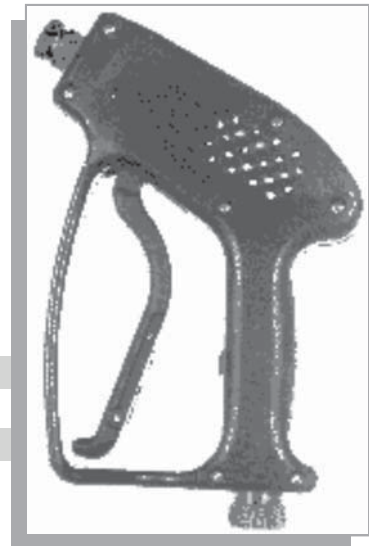

**GIANT TRIGGER GUN:**

- REINFORCED PLASTIC HANDLE
- ◆ BRASS VALVE HOUSING
  - ◆ 10 GPM MAXIMUM FLOW
  - ◆ 5,000 PSI MAXIMUM PRESSURE
  - ◆ 300°F MAXIMUM TEMPERATURE
  - ◆ 3/8" FPT INLET x 1/4" FPT OUTLET
  - ◆ 28.0 OZ. WEIGHT
- 40046 MODEL 21290B  
 40045 REPAIR KIT

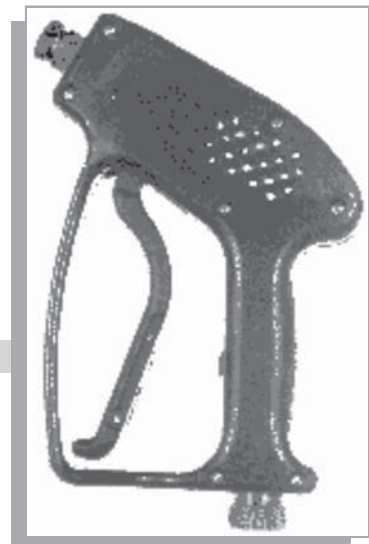

**YG6000 TRIGGER GUN:**

- ◆ *STAINLESS STEEL CONNECTOR TUBES*
  - ◆ *FORGED BRONZE BODY*
  - ◆ **21 GPM MAXIMUM FLOW**
  - ◆ **8,100 PSI MAXIMUM PRESSURE**
  - ◆ **210°F MAXIMUM TEMPERATURE**
  - ◆ **1/2" FPT STAINLESS STEEL INLET/OUTLET**
  - ◆ **80.0 OZ. WEIGHT**
- NOZ008115 MODEL 80/400  
25127 REPAIR KIT



**YG-4000S LINEAR GUN:**

- ◆ *WELL SUITED FOR HIGH REACH APPLICATIONS*
  - ◆ *FORGED BRONZE BODY*
  - ◆ *IMPACT-RESISTANT GLASS-REINFORCED NYLON HOUSING*
  - ◆ *STAINLESS STEEL BALL & SEAT*
  - ◆ *FORGED BRASS VALVE BODY*
  - ◆ *HIGH TEMPERATURE VITON SEALS*
  - ◆ **10.5 GPM MAXIMUM FLOW**
  - ◆ **4,000 PSI MAXIMUM PRESSURE**
  - ◆ **300°F MAXIMUM TEMPERATURE**
  - ◆ **3/8" FPT INLET x 1/4" FPT OUTLET**
  - ◆ **21.9 OZ. WEIGHT**
- TLS0011253 LINEAR GUN  
NOZ020456 REPAIR KIT

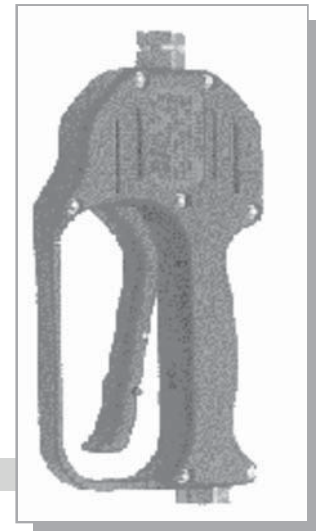

**ST-3002 WASHDOWN GUN:**

- ◆ *INDUSTRIAL TRIGGER-STYLE*
  - ◆ *RECOMMENDED REPLACEMENT FOR FLUSHING NOZZLE*
  - ◆ **25 GPM MAXIMUM FLOW**
  - ◆ **7,000 PSI MAXIMUM PRESSURE**
- NOZ007884 GUN, LANCE, & NOZZLE  
NOZ022348 REBUILD KIT  
NOZ022343 REPLACEMENT LANCE





**TRIGGER GUNS & LANCES**

**800 UDOR LONG RANGE GUN:**

- ◆ 21" BARREL
  - ◆ HIGH PRESSURE SPRAY-ADJUST AT BARREL HANDLE
  - ◆ 26 GPM MAXIMUM FLOW
  - ◆ 1,000 PSI MAXIMUM PRESSURE
- NOZ007869 GUN



**DUMP GUN, SINGLE BARREL:**

- ◆ CHOICE OF TWO BARREL LENGTHS
- ◆ BRASS BODY, STAINLESS STEEL VALVE AND SEAT
- ◆ POLYAMIDE GRIP
- ◆ STAINLESS STEEL INNER & OUTER BARREL
- ◆ 10.5 GPM MAXIMUM FLOW
- ◆ 3,000 PSI MAXIMUM PRESSURE
- ◆ 140°F MAXIMUM TEMPERATURE
- ◆ 3/8" FPT INLET x 3/8" FPT OUTLET

25124	16" LANCE DUMP GUN
22224	40" LANCE DUMP GUN



**STRAIGHT, SINGLE TUBE LANCE:**

21716	15-1/2" STAINLESS STEEL LANCE TUBE (1/4" MNPT) (4,000 PSI PRESSURE, 340°F TEMPERATURE, .05 LBS. WEIGHT)
PIP008156	24" STAINLESS STEEL LANCE TUBE (1/4" MNPT) (4,000 PSI PRESSURE, 340°F TEMPERATURE, .08 LBS. WEIGHT)
PIP008157	35-1/2" STAINLESS STEEL LANCE TUBE (1/4" MNPT) (3,600 PSI PRESSURE, 340°F TEMPERATURE, 1.2 LBS. WEIGHT)
NOZ022318	48" STAINLESS STEEL LANCE TUBE (1/4" MNPT) (3,600 PSI PRESSURE, 340°F TEMPERATURE, 3.0 LBS. WEIGHT)
NOZ007831	55" STAINLESS STEEL LANCE TUBE (1/4" MNPT) (3,600 PSI PRESSURE, 340°F TEMPERATURE, 1.8 LBS. WEIGHT)
NOZ022315	72" STAINLESS STEEL LANCE TUBE (1/4" MNPT) (3,600 PSI PRESSURE, 340°F TEMPERATURE, 2.6 LBS. WEIGHT)
21726	84" STAINLESS STEEL LANCE TUBE (1/4" MNPT) (3,600 PSI PRESSURE, 340°F TEMPERATURE, 3.0 LBS. WEIGHT)



## STRAIGHT, SINGLE TUBE LANCE W/12" ADJUSTABLE HANDLE:

21723A	15-1/2" STAINLESS STEEL LANCE TUBE (1/4" MNPT) (3,600 PSI PRESSURE, 340°F TEMPERATURE, .09 LBS. WEIGHT)
21724	24" STAINLESS STEEL LANCE TUBE (1/4" MNPT) (3,600 PSI PRESSURE, 340°F TEMPERATURE, 1.3 LBS. WEIGHT)
21721A	35-1/2" STAINLESS STEEL LANCE TUBE (1/4" MNPT) (3,600 PSI PRESSURE, 340°F TEMPERATURE, 1.5 LBS. WEIGHT)
NOZ020760	55" STAINLESS STEEL LANCE TUBE (1/4" MNPT) (3,600 PSI PRESSURE, 340°F TEMPERATURE, 2.5 LBS. WEIGHT)



## STRAIGHT, SINGLE TUBE LANCE W/15" VENTED HANDLE:

21759A	15" STAINLESS STEEL LANCE TUBE (1/4" MNPT) (3,000 PSI PRESSURE, 300°F TEMPERATURE, .09 LBS. WEIGHT)
NOZ007871	35-1/2" STAINLESS STEEL LANCE TUBE (1/4" MNPT) (3,000 PSI PRESSURE, 300°F TEMPERATURE, 1.5 LBS. WEIGHT)
NOZ007832	55" STAINLESS STEEL LANCE TUBE (1/4" MNPT) (3,000 PSI PRESSURE, 300°F TEMPERATURE, 2.3 LBS. WEIGHT)

## BENT, SINGLE TUBE LANCE:

21762A	1/4" STAINLESS STEEL LANCE TUBE (1/4" MNPT), W/30° BEND (15" VENTED HANDLE & NOZZLE PROTECTOR) (3,600 PSI PRESSURE, 300°F TEMPERATURE, 1.4 LBS. WEIGHT)
--------	---



**LANCES**

**BENT, DOUBLE TUBE LANCE:**

21780A 1/4" STAINLESS STEEL LANCE TUBE (1/4" MNPT), W/30° BEND, BRASS SEAT  
 (3,600 PSI PRESSURE, 300°F TEMPERATURE, 2.5 LBS. WEIGHT)

ACC020195 1/4" STAINLESS STEEL LANCE TUBE (1/4" MNPT), W/30° BEND, S.S. SEAT  
 (3,600 PSI PRESSURE, 300°F TEMPERATURE, 2.5 LBS. WEIGHT)



**LANCE HANDLE:**

NOZ022316 LANCE HANDLE  
 (N/A PSI PRESSURE, 3400°F TEMPERATURE, .03 LBS. WEIGHT)



**BIG STAINLESS STEEL LANCES & SIDE HANDLES:**

- ◆ HIGH PRESSURE STAINLESS STEEL PIPE
- ◆ COMPLETE W/ADJUSTABLE HANDLE & COUPLER FOR 1.4" MPT NOZLE
- ◆ 7,000 PSI WORKING PRESSURE
- ◆ 300°F MAXIMUM TEMPERATURE
- ◆ 1/2" MPT GUN CONNECTION

- 25129 SS OUTLET BUSHING-1/2" x 1/4"
- 25032 19" WAND (NPT)
- 25033 38" WAND (NPT)
- 25128 SIDE HANDLE ONLY



**REGULATORS:**

	FLOW (GPM)	PRESSURE (PSI)	TEMP. OUTLET (°F)	OUTLET (IN.)	INLET (IN.)	BYPASS (IN.)	WEIGHT (LBS.)
22965*	4.5	2,700	160°	3/8FNPT	3/8FNPT		1.2
25160	10.5	4,100	160°		3/8FBSP	1/4FBSP	1.3
25161	10.5	4,100	194°	3/8FBSP	3/8FBSP	3/8FBSP	1.5
25162	10.5	1,800	194°	3/8FBSP	3/8FBSP	3/8FBSP	1.5
22096-4000	21	5,800	194°	1/2FNPT	1/2FNPT		2.9
22096-5000	21	5,800	194°	1/2FNPT	1/2FNPT		2.9
22105	53	2,600	194°		1FNPT	3/4FNPT	1.8
22191	66	4,060	140°	1FBSP	1FBSP		4.1
22960	4.5	2,700	160°	3/8FNPT	3/8FNPT	1/4FNPT	1.2
22765A	5	4,000	160°	3/8FNPT	3/8FNPT	1/4FNPT	2.1
22765APM	5	4,000	160°	3/8FNPT	3/8FNPT	1/4FNPT	2.1
22760A	8	3,000	160°	3/8FNPT	3/8FNPT	1/4FNPT	2.1
22760APM	8	3,000	160°	3/8FNPT	3/8FNPT	1/4FNPT	2.1
23710	6.6	3,000	194°	1/2FNPT	3/8FNPT	INTERNAL	1.4
23720	6.6	4,000	194°	1/2FNPT	3/8FNPT	INTERNAL	1.4
22085	6.6	5,100	194°	3/8FNPT	3/8MNPT	3/8FNPT	1.8

\*OPTIONAL SIPHON INJECTOR AVAILABLE



**25150/25151**



**23710/23720**  
(Banjo Mount)

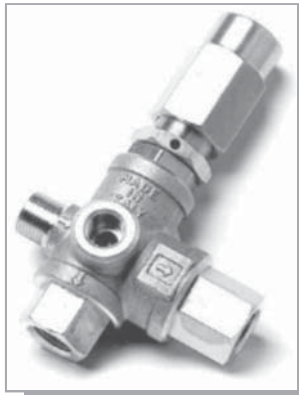

**22085**



**22760APM**  
**22765APM**



**22910A=Silver Springs**  
**22911A=Yellow Springs**  
**22912A=Red Springs**  
**22913A=Orange Springs**  
**22914= Silver Springs**  
with no gauge  
ports



**25161/25162**



**22105**



**22191**

## REGULATORS, CONT'D.:

	FLOW (GPM)	PRESSURE (PSI)	TEMP. OUTLET (°F)	OUTLET (IN.)	INLET (IN.)	BYPASS (IN.)	WEIGHT (LBS.)
22914	8	4,000	160°	1/2FNPT	1/2FNPT	1/2FNPT	2.8
25150	10.5	4,100	200°	3/8FBSP	3/8FBSP	3/8FBSP	1.5
25151	10.5	1,800	194°	3/8FBSP	3/8FBSP	3/8FBSP	1.5
22910A	13	800	160°	1/2FNPT	1/2FNPT	3/8FBSP	2.8
22911A	13	1,400	160°	1/2FNPT	1/2FNPT	1/2FNPT	2.8
22912A	13	2,400	160°	1/2FNPT	1/2FNPT	1/2FNPT	2.8
22913A	13	3,500	160°	1/2FNPT	1/2FNPT	1/2FNPT	2.8
22080	21	4,000	194°	1/2FNPT	1/2MNPT	1/2MNPT	6.7
22081	21	2,200	194°	1/2FNPT	1/2MNPT	1/2MNPT	6.7
22095-4000 <sup>B</sup>	21	5,800	194°	1/2FNPT	1/2FNPT	1/2FNPT	2.9
22095-5000 <sup>B</sup>	21	4,000	194°	1/2FNPT	1/2FNPT	1/2FNPT	2.9
22973C	26.4	4,060	160°	3/4FNPT	3/4FNPT	3/4FNPT	6.7
22971C	35.7	1,740	160°	3/4FNPT	3/4FNPT	3/4FNPT	6.7
22090	52	2,200	194°	1FNPT	1FNPT	1FNPT	4.6

**A**=303 STAINLESS STEEL    **B**=316 STAINLESS STEEL



**22080/22081**



**22095-4000/  
22095-5000**

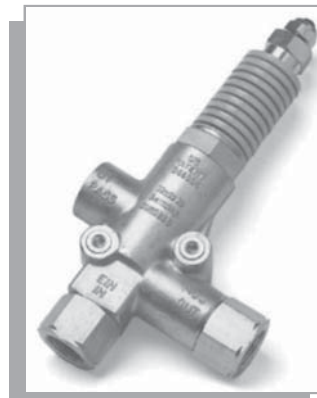

**22971C/22973C**



**25165**



**22090 Series**



**22910AR=Silver Springs  
22911AR=Yellow Springs  
22912AR=Red Springs  
22913AR=Orange Springs**



**22096-4000/  
22096-5000**

**REGULATORS, CONT'D.:**

	FLOW (GPM)	PRESSURE (PSI)	TEMP. (°F)	OUTLET (IN.)	INLET (IN.)	BYPASS (IN.)	WEIGHT (LBS.)
22950	16	5,800	160°	1FNPT	1FNPT	1FNPT	17.5
22980	26	7,200	190°	3/4BSPP	1/2BSPP	1/2BSPP	15.4
22949	32	3,200	160°	1FNPT	1FNPT	1FNPT	17.5
22948	60	1,600	160°	1FNPT	1FNPT	1FNPT	17.5
22981	66	2,200	190°	1BSPP	1BSPP	3/4BSPP	15.4
22960	4.5	2,700	160°	3/8FNPT	3/8FNPT	1/4FNPT	1.2
22765A	5	4,000	160°	3/8FNPT	3/8FNPT	1/4FNPT	2.1
22765APM	5	4,000	160°	3/8FNPT	3/8FNPT	1/4FNPT	2.1
22760A	8	3,000	160°	3/8FNPT	3/8FNPT	1/4FNPT	2.1
22760APM	8	3,000	160°	3/8FNPT	3/8FNPT	1/4FNPT	2.1
23710	6.6	3,000	194°	1/2FNPT	3/8FNPT	INTERNAL	1.4
23720	6.6	4,000	194°	1/2FNPT	3/8FNPT	INTERNAL	1.4
22085	6.6	5,100	194°	3/8FNPT	3/8MNPT	3/8FNPT	1.8



**22096-4000**



- 22948**=Yellow Springs
- 22949**=Red Springs
- 22950**=Orange Springs



**22980/22981**

**ADDITIONAL NOZZLES****PLUMBERS' SMALL NOZZLES:**

ALL ARE HEAT-TREATED STAINLESS STEEL FOR LONG SERVICE LIFE. REAR JET ANGLES (°) ARE DRILLED TO MAXIMIZE CLEANING TASKS. AVAILABLE WITHOUT FORWARD JET ON REQUEST. USE WITH 1/8", 1/4", AND 3/8" HOSE.

**1/8" SHORT:**

GENERAL PURPOSE FOR SMALL DRAINS/5/8" DIA. X 5/8" LONG

05-2 (25°)

05-3 (40°)

**1/4" PENETRATOR:**

BULLET STYLE FOR GREATER THRUSTS TO PUSH AND PENETRATE BLOCKAGES/  
3/4" DIA. X 7/8" LONG

10-6 (15°)

**1/4" HEX:**

GENERAL PURPOSE TO SWEEP AND CLEAN SIDE WALLS/5/8" DIA. X 0.9" LONG

10-5 (40°)

**1/4" BALL:**

SHORT NOZZLE WITH RECESSED THREADS FOR HARD-TO-REACH PLACES OR TO  
NEGOTIATE BENDS, TURNS, AND PROTRUSIONS/7/8" DIA. X 0.9" LONG

10-7 (35°)



**3/8" BUTTON:**

GENERAL PURPOSE FLUSHING, DESIGNED FOR TURNS AND BENDS IN SANITARY LINES/7/8" DIA. X 5/8" LONG  
15-2 (40°)

**3/8" ROTATOR:**

COMPLETELY CLEANS PIPES, FREEING GREASE, ROOT, FIBERS. A MUST FOR CONTRACTORS WITH REGULAR MAINTENANCE CONTRACTS. HAS NO FORWARD JET./3/4" DIA. X 1.7" LONG

RR-6 (3/8" HOSE)

RR-4 (1/4" HOSE)

**3/8" PENETRATOR:**

BULLET STYLE DESIGNED FOR GREATER THRUST AND PENETRATION THROUGH BLOCKAGES/15/16" DIA. X 1" LONG

15-3 (15°)

**3/8" ICE-GREASE PENETRATOR:**

SIMILAR TO PART 15-3 WITH THREE FORWARD JETS AT 5° FOR POWERFUL THRUST AND PENETRATION THROUGH BLOCKAGES/15/16" DIA. X 1" LONG

15-13 (15°)





## ADDITIONAL NOZZLES

### SMALL DRILLED NOZZLES:

ALL ARE HEAT-TREATED STAINLESS STEEL WITH MULTIPLE REAR JETS. FORWARD JET STANDARD; AVAILABLE WITHOUT FORWARD JET ON REQUEST. REAR JET ANGLES (°) DESIGNED TO MAXIMIZE CLEANING TASKS. USED PRIMARILY WITH 1/2" HOSE.

### 1/2" BUTTON:

GENERAL PURPOSE FLUSHING FOR TURNS AND BENDS/1-1/8" DIA. X 1.5" LONG  
21-2 (30° LATERAL LINE)



### 1/2" ELLIPSE PENETRATOR:

DESIGNED FOR GREATER THRUST AND PENETRATION THROUGH GREASE AND HARD SOAP/1-3/8" DIA. X 2" LONG  
21-8 (15°) HAS 1 FORWARD JET



### 1/2" UGLY:

GENERAL PURPOSE TO SWEEP AND CLEAN SIDE WALLS/5/8" DIA. X 0.9" LONG  
10-5 (40°)

### 1/2" ICE-GREASE PENETRATOR:

SHORT NOZZLE WITH RECESSED THREADS FOR HARD-TO-REACH PLACES OR TO NEGOTIATE BENDS, TURNS, AND PROTRUSIONS/7/8" DIA. X 0.9" LONG  
10-7 (35°)



**SMALL INSERTED NOZZLES:**

ALL NOZZLES HAVE REPLACEABLE HEAT-TREATED CARBIDE INSERTS IN JETS. FORWARD JET STANDARD; AVAILABLE WITHOUT FORWARD JET ON REQUEST. USE PRIMARILY WITH 1/2" HOSE. REAR JET ANGLES (°) DESIGNED TO MAXIMIZE CLEANING TASKS.

**1/2" SUPER GRENADE:**

STAINLESS STEEL. DESIGNED FOR MAINLINE WORK. STAYS IN PIPE BOTTOM WHILE BREAKING UP OBSTRUCTIONS/1-3/4" DIA. X 3" LONG/1.1 LBS.

21-5/3 (12°) HAS 3 REAR JETS

21-5/5 (12°) HAS 5 REAR JETS

**1/2" GREASE:**

SPECIAL, WEAR-RESISTANT BAR STOCK ALUMINUM. STREAMLINED TO PENETRATE GREASE, SAND, AND SLUDGE/2-1/4" DIA. X 7-1/2" LONG/2 LBS.

29 (30°) HAS 5 REAR JETS

**1/2" ULTIMATE PENETRATOR:**

ALLOY STEEL. FOR HEAVY-DUTY OBSTRUCTIONS AND CULVERTS. STAYS IN PIPE BOTTOM TO CLEAR OBSTRUCTIONS OR SOAP AND GREASE DEPOSITS/2" DIA. X 10" LONG/5 LBS.

21-6/3 (10°) HAS 3 REAR JETS

21-6/5 (10°) HAS 5 REAR JETS



## ADDITIONAL NOZZLES

### 1/2" TWISTER:

A FRONT ROTATING 20° JET OF WATER DISINTEGRATES GREASE, SOAP, ICE, HAIR AND ROOTS ON CONTACT. PERFECT FOR 4" TRAPS, 90° BENDS, AS WELL AS STRAIGHT PIPE. ALLOY STEEL WITH TWO-PIECE FRONT CERAMIC ROTATING CONE/1.3" DIA. X 2" LONG/0.4 LBS.

TW8 (6 REAR JETS)



### GREASE:

A SMOOTH, STREAMLINED NOZZLE DESIGNED TO PENETRATE AND CLEAR BLOCKAGES. REPLACEABLE CARBIDE INSERTS FOR LONG SERVICE LIFE. WEAR-RESISTANT BAR STOCK ALUMINUM/2-1/4" DIA. X 7-1/2" LONG/2 LBS.

39 3/4" HOSE: (5 REAR JETS & 1 FORWARD JET)

39 1" HOSE: (6 REAR JETS & 1 FORWARD JET)



### 12° STEEL SAND:

SHORT NOZZLE TO PENETRATE GREASE, ROOTS, SAND AND SLUDGE. ALLOY STEEL AVAILABLE FOR 1" HOSE ONLY/2" DIA. X 2-3/4" LONG/1 LB.

65F (6 REAR JETS, 2 SIDE JETS, 2 FRONT JETS)

**NOTE:** WHEN ORDERING, INDICATE HOSE SIZE, DESIRED FLOW RATE AND PRESSURE



**18° SUPER FLUSHER:**

HEAVY-DUTY NOZZLE FOR MAINLINE WORK IN 8" OR LARGER PIPE. JETS ANGLED FOR COMBINED FLUSHING AND PENETRATING. ALLOY STEEL/2-1/4" DIA. X 4-1/2" LONG/2 LBS.

80 (6 REAR JETS)

**18° SUPER FLUSHER W/LANCE TIP:**

HEAVY-DUTY NOZZLE FOR MAINLINE WORK IN 8" OR LARGER PIPE. JETS ANGLED FOR COMBINED FLUSHING AND PENETRATING. ALLOY STEEL/2-1/4" DIA. X 6" LONG/2 LBS.

80-15 (6 REAR JETS & 5 FORWARD JETS)

**NOTE:** WHEN ORDERING, INDICATE HOSE SIZE, DESIRED FLOW RATE AND PRESSURE

**RADIAL VORTEX:**

ALLOY STEEL, GENERAL PURPOSE PIPE CLEANING NOZZLE. FORWARD JET STANDARD; AVAILABLE WITHOUT FORWARD JET ON REQUEST/1 LB.

32(18°/24°) (3/4" HOSE, 6 REAR JETS, 1-9/16" DIA. X 3" LONG)  
( 1" HOSE, 6 REAR JETS, 1-7/8" DIA. X 3-3/4" LONG)  
DUAL DEGREE SWEEP FOR PENETRATING HARD SOAP, GREASE PLUGS OR ROOT MASSES

32-18(18° ONLY) (3/4" HOSE, 6 REAR JETS, 1-9/16" DIA. X 3" LONG)  
( 1" HOSE, 6 REAR JETS, 1-7/8" DIA. X 3-3/4" LONG)  
PENETRATES AND SWEEPS MANY TYPES OF OBSTRUCTIONS

**NOTE:** WHEN ORDERING, INDICATE HOSE SIZE, DESIRED FLOW RATE AND PRESSURE



## ADDITIONAL NOZZLES

### TWISTER:

A FRONT ROTATING 20° JET OF WATER DISINTEGRATES GREASE, SOAP, ICE, HAIR AND ROOTS ON CONTACT. PERFECT FOR TRAPS, 90° BENDS, AS WELL AS STRAIGHT PIPE. ALLOY STEEL WITH TWO-PIECE FRONT CERAMIC ROTATING CONE.

**TW-12** (3/4" HOSE, 8 REAR JETS, 2" DIA. X 3-5/16" LONG/1.4 LBS.)

**TW-16** ( 1" HOSE, 8 REAR JETS, 2" DIA. X 3-5/16" LONG/1.4 LBS.)

**NOTE:** WHEN ORDERING, INDICATE HOSE SIZE, DESIRED FLOW RATE AND PRESSURE



### RADIAL SHORT:

SHORT, GENERAL PURPOSE, FLUSHING NOZZLE WITH WIDE ANGLE REAR JETS TO CLEAN SIDEWALLS EFFICIENTLY. AVAILABLE WITH CHOICE OF REAR JET ANGLES (°). FORWARD JET STANDARD; AVAILABLE WITHOUT FORWARD JET ON REQUEST.

**30(30°)** (ALLOY STEEL, 1LB.)

3/4" HOSE, 5 REAR JETS, 1-9/16" DIA. X 2" LONG)

1" HOSE, 6 REAR JETS, 1-7/8" DIA. X 2-3/4" LONG)

1-1/4" HOSE, 10 REAR JETS, 2.2" DIA X 3-5/16" LONG)

**30-10ss(30°)** (STAINLESS STEEL, 1LB.)

1-1/4" HOSE, 10 REAR JETS, 2.2" DIA. X 3-5/16" LONG)

**31(45°)** (ALLOY STEEL FOR 3/4" HOSE/STAINLESS STEEL FOR 1" HOSE, 1LB.)

3/4" HOSE, 5 REAR JETS, 1-9/16" DIA. X 2" LONG)

1" HOSE, 6 REAR JETS, 1-7/8" DIA. X 2-3/4" LONG)

**NOTE:** WHEN ORDERING, INDICATE HOSE SIZE, DESIRED FLOW RATE AND PRESSURE



**RADIAL C:**

HEAT TREATED ALLOY STEEL GENERAL PURPOSE SANITARY NOZZLE. EIGHT REAR JETS STANDARD; AVAILABLE WITHOUT FORWARD JET ON REQUEST/2" DIA. X 3-1/4" LONG/1-1/4 LBS.

84(30°) (3/4" & 1" HOSES ONLY/3/4" HOSE REQUIRES A BUSHING)

**UNIVERSAL PENETRATOR:**

ALLOY STEEL NOZZLE WITH DRILLED REAR JETS POSITIONED FOR STREAMLINED PENETRATION OF ROOT FIBER, HARD GREASE AND OTHER BLOCKAGES. VARIETY OF FRONT JET STYLES FIT DIFFERENT TASKS/3/4" HOSE WITH 5 REAR JETS AND 20° JET ANGLE:3/4" DIA. X 3" LONG;1" HOSE WITH 6 REAR JETS AND 20° JET ANGLE:2" DIA. X 3-5/16" LONG/1-1/4 LBS.

33 (SINGLE JET, REAR JETS AT 20°)

33-12 (FOUR SIDE JETS AT 22°)

DRILLED LANCE TIP TO IMPACT SIDE OF PIPE AND PUSH THROUGH BLOCKAGES

33-13 (STEEP ANGLED 5° FRONT JETS)

PERFORMS BEST ON ICE/GREASE, FRONT JETS PUSH DEBRIS FORWARD AND PENETRATE HARD BLOCKAGES

33-14 (WITH PULLING EYE, NO FORWARD JET)

**NOTE:** WHEN ORDERING, INDICATE HOSE SIZE, DESIRED FLOW RATE AND PRESSURE



### **SUPER GRENADE PENETRATOR:**

HEAVY-DUTY NOZZLE FOR MAINLINE WORK. ENGINEERED TO STAY IN PIPE BOTTOM. REAR JETS HAVE REPLACEABLE CARBIDE INSERTS AND OPTIONAL FLOW STRAIGHTENERS FOR LONG SERVICE LIFE.

- 64 (3/4" HOSE, 5 REAR JETS, 12° JET ANGLE, 2-1/4" DIA. X 3-7/8" LONG, 3-1/4 LBS.)  
( 1" HOSE, 6 REAR JETS, 12° JET ANGLE, 2-5/8" DIA. X 4-1/4" LONG, 3-1/2 LBS.)  
(1-1/4" HOSE, 8 REAR JETS, 12° JET ANGLE, 3-1/4" DIA. X 5-1/2" LONG, 7 LBS.)

**NOTE:** WHEN ORDERING, INDICATE HOSE SIZE, DESIRED FLOW RATE AND PRESSURE



### **COBIA®:**

HEAVY-DUTY, MULTIPURPOSE NOZZLE CLEARS SLUDGE, MUD AND DEBRIS FROM PIPE BOTTOM. REAR JETS HAVE REPLACEABLE CARBIDE INSERTS FOR LONG SERVICE LIFE. HEAVY-DUTY CONSTRUCTION. FORWARD JET STANDARD.

- 107 (3/4" HOSE, 8 REAR JETS, 18° JET ANGLE, 3-1/2" DIA. X 5-1/2" LONG, 5 LBS., PURPLE COLOR)  
( 1" HOSE, 10 REAR JETS, 15°/20° JET ANGLE, 4" DIA. X 6-1/2" LONG, 10 LBS., ORANGE COLOR)

**NOTE:** WHEN ORDERING, INDICATE HOSE SIZE, DESIRED FLOW RATE AND PRESSURE



**SILVER SHARK:**

ALL STAINLESS STEEL NOZZLE CONQUERS HEAVY-DUTY BLOCKAGES WITH A LARGE WATER CHAMBER AND DUAL DEGREE CARBIDE WATER JETS PRODUCING STRAIGHT FLOW. HEAVY-DUTY SKID PROVIDES STREAMLINED GUIDE FOR NOZZLE TO DEVOUR OBSTRUCTIONS. TESTED AT 143 LBS. OF THRUST WITH 76 GPM AT 2050 PSI. CLEANS 8-30" DIA. PIPE. NO FORWARD JET/12-1/2" LONG/12 LBS.

**SS-1** (1" & 1-1/4" HOSES, 8 DUAL DEGREE (15° & 20°) REAR JETS WITH CARBIDE INSERTS AND FLOW STRAIGHTENERS)

**NOTE:** WHEN ORDERING, INDICATE HOSE SIZE, DESIRED FLOW RATE AND PRESSURE

**ULTIMATE PENETRATOR:**

HEAVY-DUTY NOZZLE CHOSEN BY CONTRACTORS TO CLEAR SLUDGE, MUD AND DEBRIS FROM PIPE BOTTOM. CAN BE USED TO CREATE A PATH TO CENTER A FLUSHING NOZZLE IN SEVERE BUILDUP, MINIMIZING WATER CONSUMPTION AND CLEANING TIME. REPLACEMENT CARBIDE INSERTS FOR LONG SERVICE LIFE.

**83** (12° REAR JETS ON MOST SIZES, REAR JETS ARE 15° ON 1-1/2" DIA. HOSE, FORWARD JET STANDARD, 4 FORWARD JETS (1 AT 0° & 3 AT 7°) AVAILABLE ON REQUEST FOR 1-1/2" DIA. HOSE, SAFETY ORANGE COLOR)  
 ( 3/4" HOSE, 5 REAR JETS, 2-1/2" DIA. X 12 LONG, 8 LBS.)  
 ( 1" HOSE, 5 REAR JETS, 2-5/8" DIA. X 14 LONG, 10 LBS.)  
 (1-1/4" HOSE, 8 REAR JETS, 3-1/4" DIA. X 15 LONG, 22 LBS.)  
 (1-1/2" HOSE, 10 REAR JETS, 3-1/2" DIA. X 19 LONG, 31 LBS.)

**NOTE:** WHEN ORDERING, INDICATE HOSE SIZE, DESIRED FLOW RATE AND PRESSURE





**ADDITIONAL NOZZLES****SHAMROCK-ET®:**

A STREAMLINED NOZZLE FOR SWEEPING 6-18" DIA. PIPE. PENETRATES HAIR AND ROOT MASSES, HARD GREASE AND SOAP. LUMBAR FLOW JETS PRODUCE STRAIGHT STREAMS FOR 90% FLOW EFFICIENCY. HEAT TREATED ALLOY STEEL, PLATED FOR LONG SERVICE LIFE. THRUST FINN WITH THREE LARGE REAR CARBIDE JETS SET AT 5° WITH FLOW STRAIGHTENERS. FORWARD JET STANDARD. LONG WATER PATHS FOR SMOOTH, STRAIGHT, BACKFLOW/4" DIA. X 13" LONG.

90 (3/4", 1" AND 1-1/4" HOSE SIZES)

**NOTE:** WHEN ORDERING, INDICATE HOSE SIZE, DESIRED FLOW RATE AND PRESSURE

**SPRING STEEL SKID NOZZLES:**

SWEEP STYLE FOR MID-TO-LARGE SIZE SEWER LINES. PRESSURE-WELDED STEEL NOZZLES WITH HEAT-TREATED SPRING STEEL SKID WIRE. REAR JETS WITH CARBIDE INSERTS AND FLOW STRAIGHTENERS SET AT OPTIMUM IMPACT ANGLES TO GUARANTEE LONG SERVICE LIFE.

**MINI-TADPOLE®:**

CLEARs OUT SMALLER DIAMETER LINES. FOR 3/4" AND 1" HOSE, CLEANS 6"-12" DIA. PIPE, FORWARD JET STANDARD, NINE DUAL-DEGREE (8° & 14°) REAR JETS.

101M (4" DIA. X 12" LONG/9 LBS.)

**NOTE:** WHEN ORDERING, INDICATE HOSE SIZE, DESIRED FLOW RATE AND PRESSURE

**TADPOLE®:**

CLEARs OUT LARGER DIAMETER LINES. FOR 1" HOSE, CLEANS 8"-24" DIA. PIPE, FORWARD JET STANDARD, TWELVE DUAL-DEGREE (8° & 14°) REAR JETS.

101 (5" DIA. X 15" LONG/14 LBS.)

**NOTE:** WHEN ORDERING, INDICATE HOSE SIZE, DESIRED FLOW RATE AND PRESSURE



**POLYWOG™:**

FOR 1" AND 1-1/4" HOSE. CLEANS 15-36" DIA. PIPE. FORWARD JET ON REQUEST. TWELVE DUAL DEGREE (9° & 16°) REAR JETS/6-1/2" DIA. X 17" LONG/8 LBS.

102

**NOTE:** WHEN ORDERING, INDICATE HOSE SIZE, DESIRED FLOW RATE AND PRESSURE

**LITTLE SHAMROCK™:**

FOR 1" AND 1-1/4" HOSE. CLEANS 24-60" DIA. PIPE. FORWARD JET ON REQUEST. TWELVE DUAL DEGREE (10° & 15°) REAR JETS/7-3/8" DIA. X 21" LONG/27 LBS.

103

**NOTE:** WHEN ORDERING, INDICATE HOSE SIZE, DESIRED FLOW RATE AND PRESSURE

**DOLPHIN:**

A WIDE BODY NOZZLE WITH A FLOATING REAR MANIFOLD TO COMPENSATE FOR UNEVEN PILES OF DEBRIS. EXCELLENT IN FLAT OR ELLIPTICAL PIPE. TEN REAR JETS WITH REPLACEABLE CARBIDE INSERTS AND FLOW STRAIGHTENERS. 60° FORWARD CLIMBING JET. LIVE SWIVEL TO MAINTAIN LEVEL ACTION. PULLING EYE STANDARD/11" DIA. X 13.5" LONG/47 LBS.

104 (FOR 1 & 1-1/4" HOSE)

**NOTE:** WHEN ORDERING, INDICATE HOSE SIZE, DESIRED FLOW RATE AND PRESSURE



## ADDITIONAL NOZZLES

### FINNED FANTAIL:

WEIGHTED UNDERBELLY RESTING ON SKIDS COMBINED WITH TWO LARGE FINS KEEP NOZZLE POSITIONED IN BOTTOM OF PIPE WHILE REAR JETS FAN OUT HORIZONTALLY AND IN TWO SETS OF FOUR TO SWEEP DOWNWARD/9-1/2" DIA. X 17" LONG.

**106** (1" HOSE, 8 REAR JETS WITH RECESSED REPLACEABLE CARBIDE INSERTS AND FLOW STRAIGHTENERS, LIVE SWIVEL TO MAINTAIN LEVEL ACTION, 60 LBS.)

(1-1/4" HOSE, 8 REAR JETS WITH RECESSED REPLACEABLE CARBIDE INSERTS AND FLOW STRAIGHTENERS, LIVE SWIVEL TO MAINTAIN LEVEL ACTION, 80 LBS.)

**106-FS** SAME AS ABOVE WITH FRONT STABILIZING BAR

(1" HOSE, 8 REAR JETS WITH RECESSED REPLACEABLE CARBIDE INSERTS AND FLOW STRAIGHTENERS, LIVE SWIVEL TO MAINTAIN LEVEL ACTION, 60 LBS.)

(1-1/4" HOSE, 8 REAR JETS WITH RECESSED REPLACEABLE CARBIDE INSERTS AND FLOW STRAIGHTENERS, LIVE SWIVEL TO MAINTAIN LEVEL ACTION, 80 LBS.)

**NOTE:** WHEN ORDERING, INDICATE HOSE SIZE, DESIRED FLOW RATE AND PRESSURE



### SAND & SLUDGE:

ALUMINUM ALLOY NOZZLE ENGINEERED TO SWEEP 6" AND LARGER PIPES. REAR JETS HAVE REPLACEABLE CARBIDE INSERTS AND OPTIONAL FLOW STRAIGHTENERS FOR LONGER SERVICE LIFE.

**35** (8 DUAL DEGREE REAR JETS: 17°/24°)  
(3/4" HOSE: 4" DIA. X 5" LONG/2-1/2 LBS.)  
( 1" HOSE: 4-1/2" DIA. X 6" LONG/3 LBS.)



**140** (12 TRIPLE DEGREE REAR JETS: 10°/17°/24°) **CONTRACTOR SPECIAL**  
( 1" HOSE ONLY: 4-1/2" DIA. X 6" LONG/3 LBS.)



**NOTE:** WHEN ORDERING, INDICATE HOSE SIZE, DESIRED FLOW RATE AND PRESSURE

**ROTATING BLASTERS:**

DESIGN COMBINES PATENTED DRIVE AND BRAKE JETS TO LIMIT THE ROTATIONAL SPEED AND APPLY FULL HYDRAULIC PRESSURE TO THE CLEANING TASK. THE PERFECT NOZZLE TO ELIMINATE RESIDUE FROM A SEWER LINE, ENHANCING THE USE OF TV, VIDEO AND RELINING EQUIPMENT. SEVERAL STYLES TO OPTIMIZE RESULTS. NO FORWARD JET.

SELF ROTATING AND THRUSTING HEAT-TREATED STAINLESS STEEL, POLISHED AND GROUND FOR MAXIMUM SERVICE LIFE. REPLACEABLE CARBIDE JET INSERTS. REQUIRES MINIMUM MAINTENANCE. PIPE SKID RECOMMENDED. FIXED 18° REAR THRUST JETS ADVANCE NOZZLE IN A CORKSCREW MOTION THROUGH CLOGGED PIPE.

**REAR SPRAY ROTATING (RR) BLASTER™:**

DUAL-ACTION OF REAR SPRAY THRUSTS NOZZLE FORWARD WHILE FLUSHING AWAY LOOSE DEBRIS. FOUR ROTATING WATER JETS IMPACT PIPE WALL AT 30° ANGLE.

RR-8 1/2" HOSE, 3 THRUST JETS, 1.6" DIA. X 2.8" LONG, 1-1/2 LBS.

RR-12 3/4" HOSE, 4 THRUST JETS, 2" DIA. X 3-1/2" LONG, 2-1/2 LBS.

RR-16 1" HOSE, 4 THRUST JETS, 2-1/2" DIA. X 4" LONG, 3-1/2 LBS.

**FORWARD SPRAY ROTATING (FR) BLASTER™:**

FORWARD ROTATING SPRAY IMPACTS PIPE WALL AT 30° TO LOOSEN AND DISINTEGRATE RESIDUE AHEAD OF NOZZLE. FIXED REAR THRUST JETS ADVANCE NOZZLE IN A CORKSCREW MOTION THROUGH CLOGGED PIPE AND PUSH WASTE MATERIAL BACKWARD. EXCELLENT FOR CLEARING EXTREMELY CLOGGED OR FROZEN PIPES.

FR-8 1/2" HOSE, 3 THRUST JETS, 1.6" DIA. X 2.8" LONG, 1-1/2 LBS.

FR-12 3/4" HOSE, 4 THRUST JETS, 2" DIA. X 3-1/2" LONG, 2-1/2 LBS.

FR-16 1" HOSE, 4 THRUST JETS, 2-1/2" DIA. X 4" LONG, 3-1/2 LBS.



**ADDITIONAL NOZZLES****REAR ROTATING COMBI (RRC) BLASTER™:**

FOUR ROTATING WATER JETS-TWO IMPACT PIPE WALL WITH 30° REAR SPRAY WHILE TWO PRODUCE 90° JET STREAM TO LOOSEN SIDEWALL BUILDUP AND DEBRIS.

RRC-8	1/2" HOSE, 3 THRUST JETS, 1.6" DIA. X 2.8" LONG, 1-1/2 LBS.
RRC-12	3/4" HOSE, 4 THRUST JETS, 2" DIA. X 3-1/2" LONG, 2-1/2 LBS.
RRC-16	1" HOSE, 4 THRUST JETS, 2-1/2" DIA. X 4" LONG, 3-1/2 LBS.

**FORWARD ROTATING COMBI (FRC) BLASTER™:**

FOUR ROTATING WATER JETS-TWO IMPACT PIPE WALL WITH 30° FORWARD SPRAY WHILE TWO PRODUCE 90° JET STREAM TO LOOSEN SIDEWALL BUILDUP AND DEBRIS.

FRC-8	1/2" HOSE, 3 THRUST JETS, 1.6" DIA. X 2.8" LONG, 1-1/2 LBS.
FRC-12	3/4" HOSE, 4 THRUST JETS, 2" DIA. X 3-1/2" LONG, 2-1/2 LBS.
FRC-16	1" HOSE, 4 THRUST JETS, 2-1/2" DIA. X 4" LONG, 3-1/2 LBS.

**NOTE:** WHEN ORDERING, INDICATE HOSE SIZE, DESIRED FLOW RATE AND PRESSURE

**GIANT ROTATING BLASTER:**

DESIGNED FOR BIG JOBS. USE WITH 1" AND 1-1/4" HOSE. FOR PIPE 8"-30". DUAL DEGREE JETS (30° & 90°). PIPE SKID RECOMMENDED/3-1/4" DIA. X 6" LONG/9 LBS.

RR-160	REAR ROTATING BLASTER
RRC-160	REAR ROTATING COMBI BLASTER

**NOTE:** WHEN ORDERING, INDICATE HOSE SIZE, DESIRED FLOW RATE AND PRESSURE



**BOAT NOZZLE:**

**HEAVY-DUTY FLAT BOTTOM NOZZLE WITH STABILIZING BARS AND SKIDS. CLEANS MEDIUM TO LARGE SEWER PIPE. HIGH PRESSURE WATER DISTRIBUTED THROUGH MANIFOLD TO REAR JETS SET AT OPTIMUM ANGLES TO SWEEP PIPE BOTTOM.**

**125** (1", 1-1/4" AND 1-1/2" HOSES, 11 REAR JETS WITH REPLACEABLE CARBIDE INSERTS AND FLOW STRAIGHTENERS, STAINLESS STEEL MANIFOLD, LIVE SWIVEL TO MAINTAIN LEVEL ACTION, 8" WIDE X 17-1/2" LONG, 51 LBS., SAFETY ORANGE COLOR FOR HIGH VISIBILITY)

**125-H** (1-1/2" HOSE, 11 REAR JETS WITH REPLACEABLE CARBIDE INSERTS AND FLOW STRAIGHTENERS, STAINLESS STEEL MANIFOLD, THICKER BASEPLATE AND LOWER CENTER OF GRAVITY, LIVE SWIVEL TO MAINTAIN LEVEL ACTION, 9" WIDE X 17-1/2" LONG, 60 LBS., SAFETY ORANGE COLOR FOR HIGH VISIBILITY)

**NOTE:** WHEN ORDERING, INDICATE HOSE SIZE, DESIRED FLOW RATE AND PRESSURE

**WHIRLAWAY NOZZLE:**

**BRASS HYDRANT NOZZLES FOR USE ONLY WITH FIRE HOSE. MADE IN USA.**

**5** 1-1/2" HOSE, NPT, 2-1/2" DIA. X 5-1/2" LONG, 2 LBS.

**5-NST** 1-1/2" HOSE, 2-1/2" DIA. X 5-1/2" LONG, 2 LBS.

**30** 2-1/2" HOSE, 3-1/4" DIA. X 9" LONG, 6 LBS.

**40** 2-1/2" HOSE, CUTTER BLADE ASSEMBLY, 3-1/4" DIA. X 9" LONG, 7 LBS.

**FLUSHING NOZZLE:**

**BRASS HOSE NOZZLE FOR SPECIFIC DISCHARGE. MADE IN USA.**

**158** 1/2" HOSE, 1/4" STREAM DISCHARGE, 1/2" DIA. X 6-1/2" LONG

**155** 3/4" HOSE, 1/4" STREAM DISCHARGE, 3/4" DIA. X 6" LONG

**156** 1" HOSE, 5/16" STREAM DISCHARGE, 1" DIA. X 8" LONG

**157** 1-1/4" HOSE, 3/8" STREAM DISCHARGE, 1-1/4" DIA. X 10" LONG



**EXTENSIONS & SKIDS****TUBE STYLE NOZZLE EXTENSION:**

HELP NOZZLES MOVE OVER ROUGH OR BROKEN PIPE, PREVENTING THEM FROM REVERSING OR ENTERING LATER SEWER LINES. FOR STANDARD NOZZLES, 1/2" TO 1-1/4" NPT. EXTENSION CONNECTS WITH MALE NPT x FEMALE NPT.

300	1/2" HOSE, 1-1/4" DIA. X 8" LONG
	3/4" HOSE, 2" DIA. X 12" LONG
	1" HOSE, 2-1/4" DIA. X 12" LONG
	1-1/4" HOSE, 2-1/4" DIA. X 12" LONG

**SKIDS:**

EXTENSIONS CENTER CERTAIN NOZZLES IN A PIPE, IMPROVING PERFORMANCE AND EFFICIENCY. PREVENTS NOZZLE WEAR. ALL HAVE HEAVY-DUTY COUPLING TO ATTACH TO SEWER CLEANER HOSE.

**SIX WIRE SKID:**

HEAVY WALLED EXTENSION SURROUNDED BY A CAGE OF SIX HARD SPRING STEEL WIRES. PREVENTS WEAR OF MOST NOZZLES.

695-E6	3/4" HOSE, 6" DIA. PIPE, 15-1/2" LONG
695-E812	3/4" HOSE, 8-12" DIA. PIPE, 16-3/4" LONG
695-F6	1" HOSE, 6" DIA. PIPE, 15-1/2" LONG
695-F8	1" HOSE, 8" DIA. PIPE, 16-3/4" LONG
695-F10	1" HOSE, 10" DIA. PIPE, 18-1/4" LONG
695-F1215	1" HOSE, 12-15" DIA. PIPE, 25-1/2" LONG
695-G8	1-1/4" HOSE, 8" DIA. PIPE, 15-1/2" LONG

**FOUR WIRE SKID:**

EXTENSION WITH CAGE OF FOUR OIL-HARDENED SEWER RODS. HOLDS SMALL AND STANDARD NOZZLES OFF PIPE BOTTOM. CLEANS PIPES OVER 4" DIAMETER.

696-D	1/2" HOSE, 13" LONG
696-E	3/4" HOSE, 13" LONG
696-F	1" HOSE, 14" LONG



**HEAVY-DUTY FINNED SKID:**

FINNED EXTENSION OF QUALITY WELDED STEEL FOR USE IN PIPES AT LEAST 6" DIAMETER. SKID FOR 1-1/4" HOSE CLEANS PIPES AT LEAST 8" DIAMETER.

40-D	1/2" HOSE, 10" LONG
40-E	3/4" HOSE, 12" LONG
40-F	1" HOSE, 12" LONG
40-G	1-1/4" HOSE, 15-1/2" LONG

**WATER JET ROOT CUTTERS:****COMMERCIAL DUTY:**

CARVES THROUGH OBSTRUCTIONS IN 6-15" PIPE. SUPPORTS CONCAVE, CIRCULAR, SPRING BLADE AND CABLE STYLE CUTTERS AND ARROW ROOTERS™.

- 902
- 1" SHAFT DIAMETER
  - FOR 3/4" AND 1" HOSE
  - INTERNALLY PORTED HYDRAULIC POWER UNIT WITH BUILT-IN GREASE SYSTEM
  - 1,450 INCH-POUNDS TORQUE
  - 450-500 RPMS
  - 3-1/3" DIA. x 1" LONG
  - WEIGHS 14 LBS.
  - REPLACEMENT MOTOR AND NOZZLE ONLY, AVAILABLE

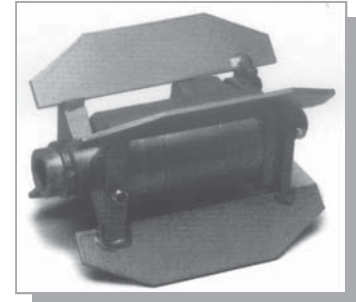
**CONTRACTOR DUTY:**

CLEANS PIPES 6-18" DIAMETER. SUPPORTS SPECIAL 18" ROOT CUTTER BLADE AS WELL AS OTHER COLOR-CODED CONCAVE, CIRCULAR, CABLE-STYLE CUTTERS AND ARROW ROOTERS™.

- 906
- 1" SHAFT DIAMETER
  - INTERNALLY PORTED, HEAVY-DUTY HYDRAULIC POWER UNIT WITH BUILT-IN GREASE SYSTEM
  - 2,250 INCH-LBS TORQUE PREVENTS STALLING
  - 300-350 RPM SPEED INSURES EXTENDED TOOTH LIFE
  - OPERATES WELL AT 50-80 GPM AND 1,500-2,000 PSI
  - 5" DIA. x 9" LONG
  - WEIGHS 20 LBS.
  - WHITE COLOR
  - REPLACEMENT MOTOR AND NOZZLE ONLY, AVAILABLE



•MAY BE USED WITH DIAMOND SAWS AND 3/4" 60+ HP JET UNITS



**ROOT CUTTER KITS-COMMERCIAL DUTY & CONTRACTOR DUTY:**

FOR PART NOS. 902 AND 906.

**INCLUDES:**

- MOTOR
- CHOICE OF THREE COLOR-CODED CONCAVE CIRCULAR SAWS UP TO 12" DIA.
- CHOICE OF THREE SKIDS
- TOOL BOX
- HARDWARE
- ASSEMBLY INSTRUCTIONS (NO TOOLS REQUIRED)
- 15-18" SAWS AVAILABLE IN KIT AT SLIGHTLY HIGHER PRICE

**COMMERCIAL DUTY KIT:902-3/4;902-1****CONTRACTOR DUTY KIT:906-3/4;906-1****CONCAVE CIRCULAR SAW CHOICES:**

<b>1100-4</b>	WELDED-ON ARBOR, 4" DIA. PIPE, GREEN BLADE COLOR
<b>1205-4</b>	BOLTED-ON ARBOR, 4" DIA. PIPE, GREEN BLADE COLOR
<b>1100-6</b>	WELDED-ON ARBOR, 6" DIA. PIPE, RED BLADE COLOR
<b>1205-6</b>	BOLTED-ON ARBOR, 6" DIA. PIPE, RED BLADE COLOR
<b>1100-8</b>	WELDED-ON ARBOR, 8" DIA. PIPE, WHITE BLADE COLOR
<b>1205-8</b>	BOLTED-ON ARBOR, 8" DIA. PIPE, WHITE BLADE COLOR
<b>1100-10</b>	WELDED-ON ARBOR, 10" DIA. PIPE, BLUE BLADE COLOR
<b>1205-10</b>	BOLTED-ON ARBOR, 10" DIA. PIPE, BLUE BLADE COLOR
<b>1100-12</b>	WELDED-ON ARBOR, 12" DIA. PIPE, ORANGE BLADE COLOR
<b>1205-12</b>	BOLTED-ON ARBOR, 12" DIA. PIPE, ORANGE BLADE COLOR
<b>1100-15</b>	WELDED-ON ARBOR, 15" DIA. PIPE, PURPLE BLADE COLOR
<b>1205-15</b>	BOLTED-ON ARBOR, 15" DIA. PIPE, PURPLE BLADE COLOR
<b>1100-18RT</b>	WELDED-ON ARBOR, 18" DIA. PIPE, GRAY BLADE COLOR

**SKID CHOICES:**

<b>902-R</b>	RING, COMMERCIAL DUTY
<b>906-R</b>	RING, CONTRACTOR DUTY
<b>902-6</b>	6" DIA. PIPE, COMMERCIAL DUTY
<b>906-6</b>	6" DIA. PIPE, CONTRACTOR DUTY
<b>902-8</b>	8" DIA. PIPE, COMMERCIAL DUTY
<b>906-8</b>	8" DIA. PIPE, CONTRACTOR DUTY
<b>902-10</b>	10" DIA. PIPE, COMMERCIAL DUTY
<b>906-10</b>	10" DIA. PIPE, CONTRACTOR DUTY
<b>902-12</b>	12" DIA. PIPE, COMMERCIAL DUTY
<b>906-12</b>	12" DIA. PIPE, CONTRACTOR DUTY
<b>902-15</b>	15" DIA. PIPE, COMMERCIAL DUTY
<b>906-15</b>	15" DIA. PIPE, CONTRACTOR DUTY
<b>902-18</b>	18" DIA. PIPE, COMMERCIAL DUTY
<b>906-18</b>	18" DIA. PIPE, CONTRACTOR DUTY

**HYDRAULIC BLADE CUTTERS:**

CUT THROUGH OBSTRUCTIONS THAT CAN'T BE PUSHED OR BROKEN UP BY A NOZZLE.

**HYDRO ROOTER 5:**

CARVES THROUGH OBSTRUCTIONS IN 4-12" PIPE. FOR USE WITH 1/2" AND 3/4" HOSE, ESPECIALLY FOR ROOTS IN RESIDENTIAL OR SMALL COMMERCIAL SEWER PIPES.

905 5/8" SHAFT DIAMETER, CAN USE CIRCULAR AND BLADE CUTTER STYLE BLADES, 5 HP HYDRAULIC MOTOR/NOZZLE UNIT WITH BUILT-IN GREASE SYSTEM, 2-3/8" DIA. X 8-78" LONG, 6 LBS./**SPECIFY HOSE SIZE WHEN ORDERING**

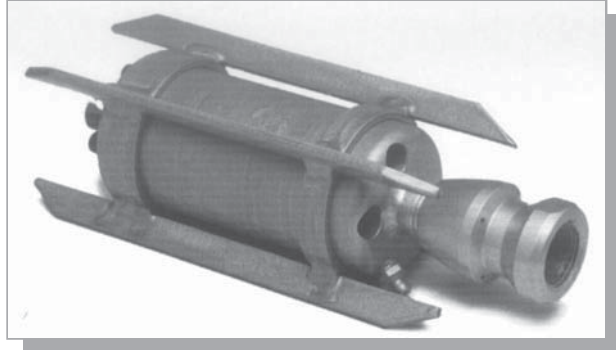
**HYDRO ROOTER 5 KIT:****INCLUDES:**

- MOTOR
- CHOICE OF THREE COLOR-CODED SAWS
- CHOICE OF THREE SKIDS
- TOOL BOX
- HARDWARE
- ASSEMBLY INSTRUCTIONS (NO TOOLS REQUIRED)



<b>3HDP-W</b>	3" DIA. PIPE, SAW NO., YELLOW BLADE COLOR
<b>905-3</b>	3" DIA. PIPE, SKID NO., YELLOW BLADE COLOR
<b>4HDP-W</b>	4" DIA. PIPE, SAW NO., GREEN BLADE COLOR
<b>905-4</b>	4" DIA. PIPE, SKID NO., GREEN BLADE COLOR
<b>6HDP-W</b>	6" DIA. PIPE, SAW NO., RED BLADE COLOR
<b>905-6</b>	6" DIA. PIPE, SKID NO., RED BLADE COLOR
<b>8HDP-W</b>	8" DIA. PIPE, SAW NO., WHITE BLADE COLOR
<b>905-8</b>	8" DIA. PIPE, SKID NO., WHITE BLADE COLOR
<b>10HDP-W</b>	10" DIA. PIPE, SAW NO., BLUE BLADE COLOR
<b>905-10</b>	10" DIA. PIPE, SKID NO., BLUE BLADE COLOR
<b>12HDP-W</b>	12" DIA. PIPE, SAW NO., ORANGE BLADE COLOR
<b>905-12</b>	12" DIA. PIPE, SKID NO., ORANGE BLADE COLOR

**NOTE:** ADD A BLADE STYLE CUTTER TO THE HYDRO ROOTER 5/REPLACEMENT MOTOR AND NOZZLE AVAILABLE

## HYDRAULIC BLADE CUTTERS:

CUT THROUGH OBSTRUCTIONS THAT CAN'T BE PUSHED OR BROKEN UP BY A NOZZLE.

## SCOOTER ROOTER II:

ROLLS OVER OFF-SET JOINTS, DEBRIS AND ROUGH SPOTS. SUPPORTS SUPER-DUTY CONCAVE AND COLOR-CODED CIRCULAR SAWS, CABLE CUTTERS AND ARROW ROOTERS™.

**902-SR** 1" SHAFT DIAMETER, FOR 3/4" AND 1" HOSES, CLEANS 8-15" DIAMETER SEWER LINES, GREASE-ABLE EXHAUST PORTS, SLOW SPEED HYDRAULIC HIGH-TORQUE MOTOR, STEEL SKIDS WITH HIGH DENSITY POLYETHYLENE WHEELS, OSHA ORANGE, REPLACEMENT MOTOR AND NOZZLE

**\*SPECIFY HOSE SIZE WHEN ORDERING**

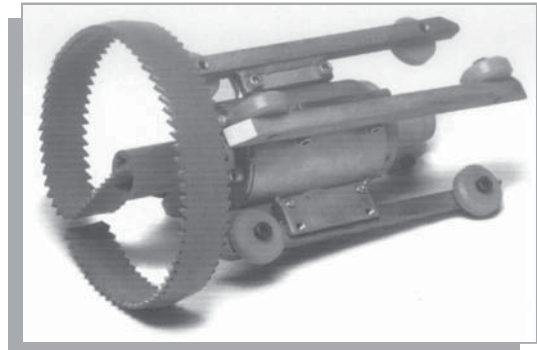

## HYDRO ROOTER 5 KIT:

### INCLUDES:

- MOTOR
- THREE CONCAVE CIRCULAR COLOR-CODED BLADES (CHOICE OF 6", 8", 10", 12" CIRCULAR)
- CHOICE OF TWO SKIDS (8-10" AND 12-15")
- TOOL BOX
- HARDWARE
- ASSEMBLY INSTRUCTIONS

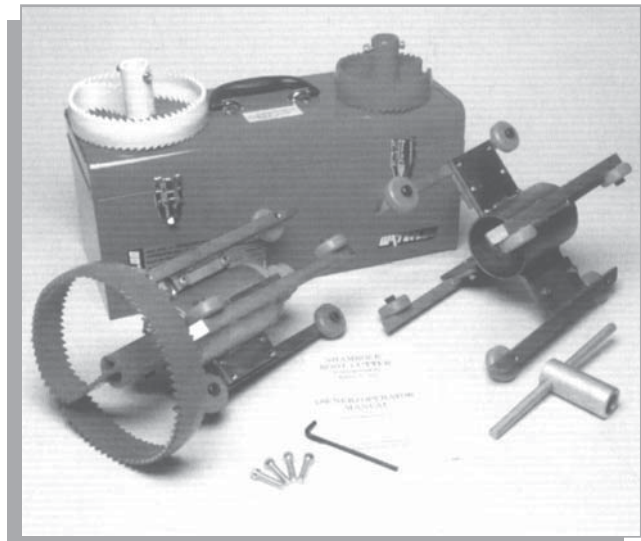

**902-SR3/4;902-SR1**

**CHAIN CUTTER:**

SCRAPES PIPES AS IT ROTATES.

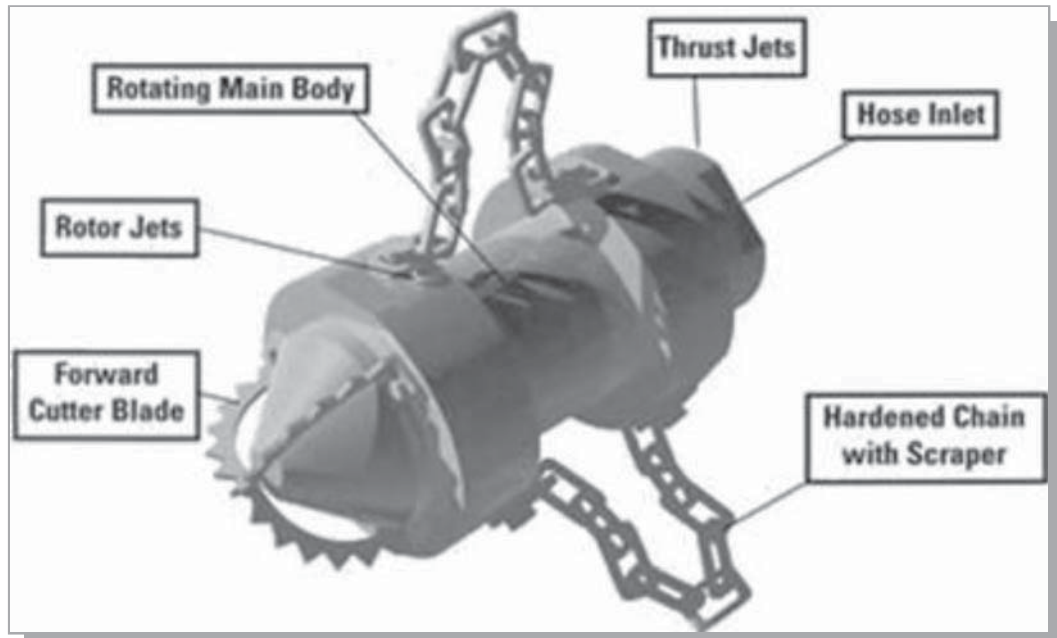
**CHAIN CUTTER KIT:**

TO ORDER: START WITH A KIT:

**INCLUDES:**

- ONE NOZZLE
- 4", 6" AND 8" CHAIN ASSEMBLIES
- CHOICE OF THREE SKIDS
- ONE 6-WIRE SKID
- TOOL BOX
- HARDWARE

<b>CHACUT-01-8K</b>	FOR 1/2" HOSE
<b>CHACUT-01-12K</b>	FOR 3/4" HOSE
<b>CHACUT-01-16K</b>	FOR 1" HOSE

**TO ORDER SEPARATELY:**

<b>CHACUT-01-8</b>	CUTTER NOZZLE* FOR 1/2" HOSE
<b>695-1-8/A</b>	SKID FOR 1/2" HOSE
<b>CHACUT-01-12</b>	CUTTER NOZZLE* FOR 3/4" HOSE
<b>695-1-8</b>	SKID FOR 3/4" HOSE
<b>CHACUT-01-16</b>	CUTTER NOZZLE* FOR 1" HOSE

\*NEW CUTTER NOZZLE INCLUDES CUTTER HEAD AND 6" CHAIN ASSEMBLY

**TO ORDER EXTRA CHAIN ASSEMBLIES:**

<b>CC1-4</b>	FOR 4" DIA. PIPE
<b>CC1-6</b>	FOR 6" DIA. PIPE
<b>CC1-8</b>	FOR 8" DIA. PIPE

**REPLACEMENT PARTS:**

<b>CC1-CH</b>	CUTTER HEAD
---------------	-------------

## CABLE ROOTER:

SCRAPES FULL PIPE DIAMETER, REMOVING GREASE, SCALE, ROOTS AND DEBRIS FROM CAST IRON AND STORM SEWER PIPES. USE ON ALL HYDRAULIC ROOT CUTTER MOTORS. FLEXIBLE CABLE PASSES OVER PROJECTILES AND OFFSET JOINTS.

**CR-K** KIT INCLUDES THREE COLOR-CODED CABLE SETS (6", 8", 10"), #CR-A ARBOR, TOOL BOX, HARDWARE



### CABLE CHOICES:

- CR-6** 6" DIA. PIPE, RED CABLE
- CR-8** 8" DIA. PIPE, WHITE CABLE
- CR-10** 10" DIA. PIPE, BLUE CABLE
- CR-12** 12" DIA. PIPE, ORANGE CABLE
- CR-15** 15" DIA. PIPE, PURPLE CABLE

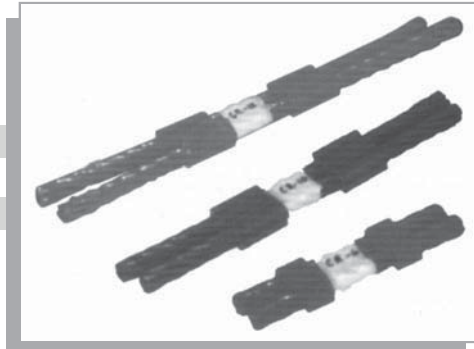

**CR-A** REPLACEMENT ARBOR



## DIAMOND LATERAL CUTTER:

SLICES LATERALLY THROUGH CAST IRON, 3/4" REBAR AND ANCHORS, CLAY TILE AND CONCRETE PROTRUDING INTO SEWER LINES. ALTHOUGH MAY BE USED ON PLASTIC PIPE, PVC LATERAL CUTTER IS RECOMMENDED.

**DTS** BALANCED HIGH TORQUE HYDRAULIC MOTOR, RATED AT 35 GPM AT 1500 PSI, 1" KEYED SHAFT, FINNED SKID POSITIONS INDUSTRIAL DIAMOND-IMBEDDED BLADE, CAN BE USED ON SEWER CLEANERS 35-80 GPM AND 1500-2500 PSI, AVAILABLE TO CLEAR 6", 8", 10", AND 15" DIA. PIPES, REPLACEMENT MOTOR AND NOZZLE AVAILABLE



**DIAMOND LATERAL CUTTER KIT:**

TAP CUTTER AVAILABLE FOR 3/4" UNIT TO CUT TAPS IN 6" AND 8" LINES ONLY.  
WHEN ORDERING, INDICATE PIPE SIZE, HOSE SIZE, FLOW RATE AND PRESSURE.

**INCLUDES:**

- MOTOR
- ONE DIAMOND SAW AND SKID
- CHOICE OF THREE SKIDS
- TOOL BOX
- HARDWARE
- OPERATING INSTRUCTIONS

**DIAMOND SAW AND SKID CHOICES:**

<b>906-6DTK</b>	KIT NO. FOR 6" DIA. PIPE
<b>DTS-6</b>	SAW PART NO. FOR 6" DIA. PIPE
<b>906-6</b>	SKID PART NO. FOR 6" DIA. PIPE
<b>906-8DTK</b>	KIT NO. FOR 8" DIA. PIPE
<b>DTS-8</b>	SAW PART NO. FOR 8" DIA. PIPE
<b>906-8</b>	SKID PART NO. FOR 8" DIA. PIPE
<b>906-10DTK</b>	KIT NO. FOR 10" DIA. PIPE
<b>DTS-10</b>	SAW PART NO. FOR 10" DIA. PIPE
<b>906-10</b>	SKID PART NO. FOR 10" DIA. PIPE
<b>906-12DTK</b>	KIT NO. FOR 12" DIA. PIPE
<b>DTS-12</b>	SAW PART NO. FOR 12" DIA. PIPE
<b>906-12</b>	SKID PART NO. FOR 12" DIA. PIPE
<b>906-15DTK</b>	KIT NO. FOR 15" DIA. PIPE
<b>DTS-15</b>	SAW PART NO. FOR 15" DIA. PIPE
<b>906-15</b>	SKID PART NO. FOR 15" DIA. PIPE

**PVC PIPE LATERAL CUTTER:**

HEAT-TREATED SERRATED TEETH CUT PROTRUDING PVC PIPE IN SEWER LINES  
BETTER THAN DIAMOND CUTTER. USE ONLY TO CUT PLASTIC PIPE.

**\*SPECIFY PIPE SIZE AND CUTTER MOTOR (902 COMMERCIAL OR 906 CONTRACTOR) WHEN ORDERING**

<b>CTS-6</b>	FOR 6" DIA. PIPE
<b>CTS-8</b>	FOR 8" DIA. PIPE
<b>CTS-10</b>	FOR 10" DIA. PIPE
<b>CTS-12</b>	FOR 12" DIA. PIPE
<b>CTS-15</b>	FOR 15" DIA. PIPE

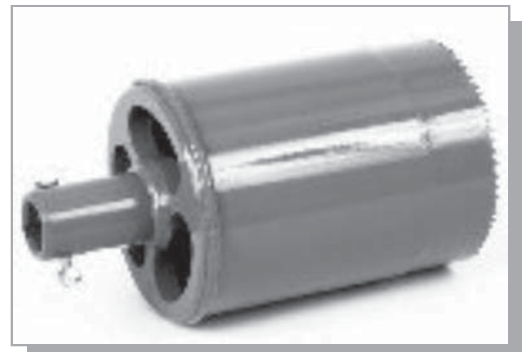

# SAWS & CUTTERS

## PVC PIPE LATERAL CUTTER KIT:

### INCLUDES:

- MOTOR (CHOICE OF 902-3/4M, -1M OR 906-3/4M, -1M)
- ONE PVC PIPE SAW AND SKID
- TOOL BOX
- HARDWARE
- OPERATING INSTRUCTIONS

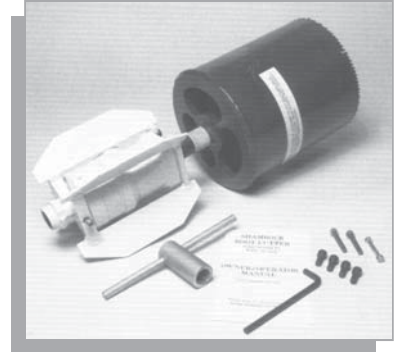

**NOTE:** SPECIFY HOSE SIZE WHEN ORDERING

### SAW AND SKID CHOICES:

PIPE SIZE IN INCHES	SAW NO.	COMM. DUTY SKID NO.	CON. DUTY SKID NO.	COMM DUTY KIT NO.	CON DUTY KIT NO.
6"	CTS-6	902-6	906-6	902-6CTK	906-6CTK
8"	CTS-8	902-8	906-8	902-8CTK	906-8CTK
10"	CTS-10	902-10	906-10	902-10CTK	906-10CTK
12"	CTS-12	902-12	906-12	902-12CTK	906-12CTK
15"	CTS-15	902-15	906-15	902-15CTK	906-15CTK

## CONCAVE SAW ARBOR:

FOR BOLT-ON SAWS, INCLUDES HEX CAP SCREW, CROSS BOLT AND LOCK NUT.

- 1205A 5/8" ARBOR
- 1205B 1" ARBOR



## SPRING BLADE CHUCK:

1" SHAFT FOR USE ON 902 AND 906 MOTORS, 5/8" SHAFT FOR USE ON 905 MOTORS. REPLACEMENT CHUCK FOR BLADE STYLE CUTTER

- 114 1" SHAFT
- 114A 5/8" SHAFT

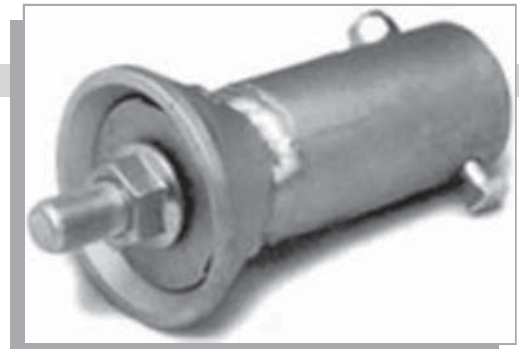

**SPRING BLADE STYLE CUTTER:****SET OF THREE BLADES.****BLADE CHOICES:**

<b>4CUT</b>	FOR 4" DIA. PIPE
<b>6CUT</b>	FOR 6" DIA. PIPE
<b>8CUT</b>	FOR 8" DIA. PIPE
<b>10CUT</b>	FOR 10" DIA. PIPE
<b>12CUT</b>	FOR 12" DIA. PIPE
<b>15CUT</b>	FOR 15" DIA. PIPE
<b>18CUT</b>	FOR 18" DIA. PIPE

**CIRCULAR, CONCAVE STYLE CUTTER:**

DESIGNED TO PROTECT PIPE WALLS FROM THE SAW'S TEETH. IDEAL FOR CUTTING OBSTRUCTIONS IN PLASTIC PIPE AND OFFSET PIPE JOINTS.

- HIGH-STRENGTH MANGANESE STEEL
- HEAT TREATED AND TEMPERED
- AVAILABLE WITH WELDED OR BOLT-ON ARBORS
- COLOR CODED FOR EASY RECOGNITION AND USE
- CONCAVE SHAPE OF BLADE KEEPS TEETH AWAY FROM PIPE WALLS, REDUCING WEAR AS THE CIRCULAR BLADE ROTATES TO SLICE THROUGH ROOTS AND OTHER OBSTRUCTIONS

**SAW CHOICES:**

PIPE SIZE	WELDED ARBOR 5/8" SHAFT	WELDED ARBOR 1" SHAFT	BOLT-ON SAW	BLADE COLOR
3"	3HDP-W			YELLOW
4"	4HDP-W	1100-4	1205-4	GREEN
6"	6HDP-W	1100-6	1205-6	RED
8"	8HDP-W	1100-8	1205-8	WHITE
10"	10HDP-W	1100-10	1205-10	BLUE
12"	12HDP-W	1100-12	1205-12	ORANGE
15"		1100-15	1205-15	PURPLE
18"		1100-18RT		GRAY





**SAWS & CUTTERS****ARROW ROOTER™:**

ROTATING ARROW POINT PIERCES AND PENETRATES EXTREMELY THICK ROOT BLOCKAGES.

- HEAT-TREATED WEAR RESISTANT MANGANESE STEEL
- FITS ON 902, 905 OR 906 MOTORS

AR-4 FOR 4" DIA. PIPE

**NOTE:** FOLLOWING SIZES TO BE DISCONTINUED.  
AVAILABLE ONLY WHILE SUPPLIES LAST.

AR-6 FOR 6" DIA. PIPE

AR-8 FOR 8" DIA. PIPE

AR-10 FOR 10" DIA. PIPE

**SEWER CLEANING EQUIP.****UPPER MANHOLE GUIDE:**

5300.01B

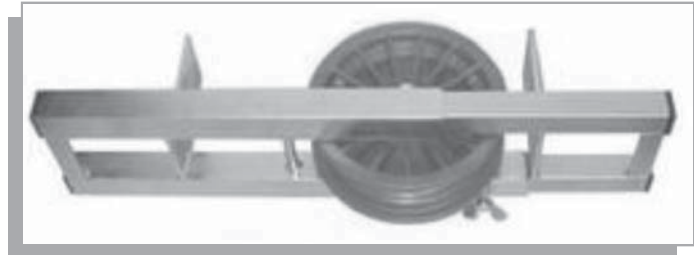
**LOWER MANHOLE GUIDE:**

5300.02B



This page left intentionally blank

**GapVax<sup>®</sup>**

**SECTION F:**  
**GAPVAX SYSTEM PARTS**

## TOOLBOXES:

- BOX00810 POLISHED ALUMINUM (SIZE: 24"x24"x30")
- BOX00812 STEEL (SIZE: 24"x24"x30")
- AO11267 LEFT MOUNTING BRACKET
- AO11268 RIGHT MOUNTING BRACKET

## LOAD INDICATORS:

### FLOAT BALL LOAD LEVEL INDICATOR:

- GAU006470 SHORT STEM INDICATOR W/STAINLESS STEEL BALL
- GAU006469 LONG STEM LEVEL INDICATOR W/STAINLESS STEEL BALL
- GAU006468 LEVEL INDICATOR W/6" PLASTIC BALL

### REPLACEMENT PARTS:

- GAU006469 INDICATOR ARROW
- GAU006132 VITON SEALING GASKET ON TANK
- GAU006466 6" FOAM FILLED PLASTIC BALL
- GAU006464 6" STAINLESS STEEL BALL
- GAU006471 FLOAT PIVOT WELDMENT
- GAU006134 VITON O-RINGS (2 REQUIRED)



## FLOAT BALLS:

### STAINLESS STEEL FLOAT BALL (NO HOLE):

- VAL012041 3"
- VAL01204 4"
- VAL012043 6"
- VAL012044 8"
- VAL012086 10"
- VAL012008 12"



## RUBBER ISOLATION MOUNTS:

- CON001134 TRANSFER CASE MOUNTS
- PUM009246 HIBON BLOWER MOUNTS
- CON001135 ROOTS BLOWER MOUNTS



**FENDERS:**

- ACC000296 ALUMINUM TANDEM FENDER
- ACC000298 STAINLESS STEEL TANDEM FENDER
- ACC000294 ALUMINUM SINGLE WHEEL FENDER

**PULSATOR PARTS:**

- BOX000776 PULSATOR BOX
- BOX000774 PULSATOR BOX INSIDE PANEL
- ELE001881 12V-24V DC TIMER BOARD
- ELE001962 12V SOLENOID
- VAL012992 12V SOLENOID
- VAL011826 3/4" PULSE VALVE ON PULSATOR

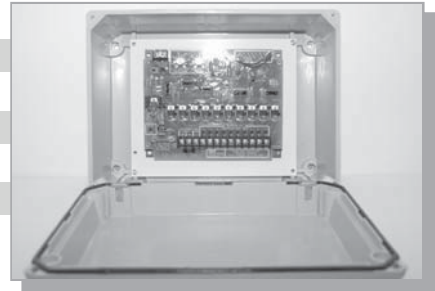

**REPLACEMENT GASKETS:**

- GAS006283 OLD STYLE BAG DOOR GASKET
- GAS006284 OLD STYLE BAG DOOR GASKET
- GAS006280 NEW STYLE BAG DOOR GASKET
- GAS006281 NEW STYLE BAG DOOR GASKET
- GAS006282 NEW STYLE BAG DOOR GASKET
- GAS006286 DUCTWORK GASKET
- GAS006287 DUCTWORK GASKET
- GAS006288 DUCTWORK GASKET
- GAS006289 DUCTWORK GASKET
- GAS006290 DUCTWORK GASKET
- GAS006291 DUCTWORK GASKET
- GAS006285 5" RING GASKET FOR BLOW-OFF
- GAS006292 OLD STYLE ROUND DUMP CHUTE GASKET
- GAS000206 NEW STYLE OVAL DUMPCHUTE GASKET
- GAS006294 TAILGATE GASKET
- GAS005990 8" ROUND CLEANOUT DOOR GASKET
- GAS006252 5" SQUARE GASKET
- VAL012106 FLOATBALL GASKET
- CLA000907 CLAMP FOR FLOATBALL GASKET
- GAS006402 BLOWER TO PLENUM GASKET
- GAS006400 16" OLD STYLE PLENUM GASKET
- GAS006404 14" SILENCER GASKET-DVJ BLOWER
- GAS006405 NEW STYLE MANIFOLD TO SILENCER GASKET
- CLA001035 5" CLAMP FOR W-39899-7 (2 REQUIRED)
- CLA001038 8" CLAMP FOR W-39899-7 (2 REQUIRED)
- HOS006633 BODY BREAK COIL
- CLA000881 5" CLAMP FOR #1095 (2 REQUIRED)



## CONTROL PANELS/PARTS:

GAU006497	VAC GAUGE
ELE001616	LIGHT
ZB2BA9124	BLACK & RED THROTTLE BUTTON
800E26X20	OPERATOR FOR #ZB2BA9124
800EMSM22	ON-OFF TURN SWITCH
800EMFS	YELLOW PUSH BUTTON
800EMF4	RED PUSH BUTTON
800E2LX10	CONTACT BLOCK
800E2LX01	OPERATOR FOR #ZB2BA4
GAU006483	TEMPERATURE GAUGE
LHT007745	RED PILOT LIGHT
GAU006542	TACHOMETER W/HOUR METER
800E2X01	OPERATOR N/C
800EMMT4	EMERGENCY SHUT-OFF BUTTON
<b>CONTROL PANEL W/PRESSURE GAUGE</b>	
<b>USE SAME AS ABOVE PARTS PLUS COMBINATION VAC/PRESSURE GAUGE</b>	
GAU006498	

## HYDRAULIC CYLINDERS:

CYL001234	DOUBLE-ACTING BED LIFT CYLINDER (FOR TRUCKS WITH 2)
CYL001235	REBUILT DOUBLE-ACTING BEDLIFT CYLINDER
DAT73-73-150	DOUBLE-ACTING BED LIFT CYLINDER (FOR TRUCKS WITH 1)
CYL001227	OLD STYLE MONARCH TAILGATE LIFT CYLINDER
PMC-8312	NEW STYLE TAILGATE LIFT CYLINDER
WSO200-04.00	NEW STYLE TAILGATE LOCK CYLINDER
SAE9210	BOOM LIFT CYLINDER
PMC-5442	EXTENDABLE BOOM CYLINDER
PMC-5542	CYLINDER TO RAISE CYCLONE ON TRAILER
CYL001236	DAT-63-276-150
CYL001237	DAT73-73-119
CYL001239	DAT62-107-150
CYL022300	DAT62-90-97
CYL022302	DAT83-49-175

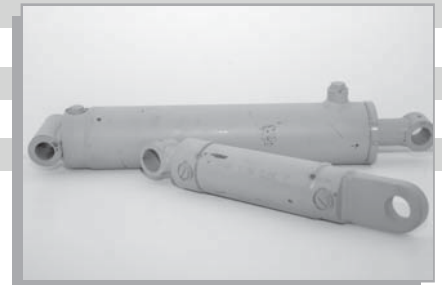

## HYDRAULIC TANKS:

TNK011410	50 GALLON HYDRAULIC TANK
FIL003527	REPLACEMENT FILTER & FILTER HEAD
FIL003587	REPLACEMENT FILTER
TNK011436	CAP W/STRAINER
TNK011415	SIGHT GLASS



## HYDRAULIC PUMP:

P20A-396	STANDARD HYDRAULIC PUMP
----------	-------------------------

**COLLECTOR BODY/INLET CANNON:**

AO11042	STANDARD CANNON
AO10144	CANNON FOR PRESSURIZED TRUCK
AO11211	CANNON EXTENSION
AO50047	PRESSURE CANNON WITH BOOM

**PRESSURIZED CANNON PLUG:**

FO12627	CANNON PLUG
FO10146	BACKING PLATE



**SECONDARY SHUTOFF:**

VAL011549	COMPLETE 3" SECONDARY SHUTOFF
VAL011651	RUBBER SEAT
VAL012132	RUBBER BALL
GAS006138	O-RING
GAS006139	O-RING
GAS006137	O-RING
VAL012133	LOWER BOTTOM BOWL
VAL012134	3/4" DRAIN VALVE
VAL011653	3" INNER CURVE
VAL011655	BODY
VAL011652	3" OUTER CURVE
1146-006	SCREW
VAL011654	STRAIGHT CONNECTION

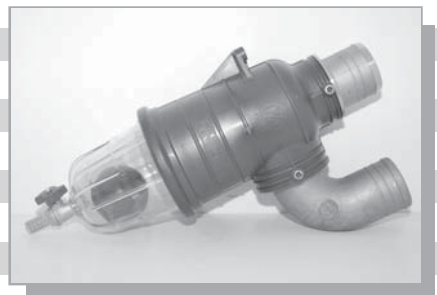

**TAIL LIGHT BOXES:**

LHT007682	LEFT TAIL LIGHT BOX W/LIGHTS
LHT007683	RIGHT TAIL LIGHT BOX W/LIGHTS

**VIBRATION DAMPENER:**

DRI001573	HI-VAC VIBRATION DAMPENER
-----------	---------------------------

**MANWAYS:**

1010-35 20" ALUMINUM LID W/6" STEEL NECK  
BOX000723 20" STEEL MANWAY W/6" NECK

**REPLACEMENT PARTS:**

1010-3506 6" STEEL NECK ASSEMBLY  
BOX00712 ALUMINUM LID W/GASKET  
BOX00713 WEAR PLATE  
FAS003216 STAINLESS STEEL SCREW  
FAS003217 STAINLESS STEEL NUT  
BOX00714 CAM LEVER  
BOX000715 UPPER PIVOT PIN  
BOX000716 LOWER PIVOT PIN  
BOX000717 CLAMP STUD  
FAS003218 JAM NUT  
CON001058 CONNECTOR  
1010-3912 PAL NUT  
BOX000718 COTTER PIN  
BOX000719 SAFETY CATCH  
BOX000720 SAFETY CATCH PIN  
BOX000721 WASHER  
BOX000722 HINGE PIN  
FAS003220 SCREW  
GAS006126 GASKET  
BOX000724 20" STEEL MANWAY W/12" NECK  
BOX000725 20" S.S. MANWAY W/6" NECK  
1010 21" STEEL MANWAY W/6x3/16" THICK NECK W/6 WINGNUTS  
BOX020613 20" ALUMINUM MANWAY W/6" S.S NECK

**REPLACEMENT PARTS:**

FAS003215 5/8" ZINC PLATED WINGNUT  
BOX000706 GALVANIZED WASHER  
FAS002636 5/8"x5" ZINC PLATED EYEBOLT  
FAS002637 ZINC PLATED PIN  
FAS022372 ROLL PIN  
BOX000729 HINGE PIN  
GAS006124 GASKET  
BOX000705 LID ASSEMBLY

**VIBRATORS:**

ELE001876 12V-DC ELECTRIC MODEL  
MOT007804 HYDRAULIC MODEL  
CB12V CIRCUIT BREAKER FOR ELECTRIC MODEL  
ELE001878 DC-3500-R  
MOT007786 HYDRAULIC MOTOR  
MOT020306 ELECTRIC MOTOR

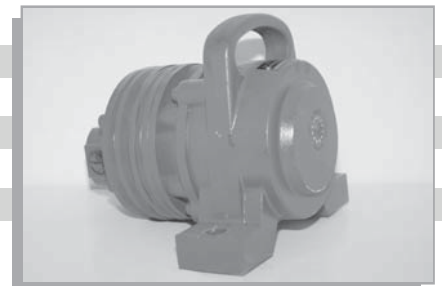



**AUGER PARTS:**

BOX00736	GEARBOX
MOT007765	MOTOR
AO10395	BOTTOM BEARING ASSEMBLY
ACC022356	9" AUGER SCREW
FO10394	TOP AUGER SHAFT
FO10393	BOTTOM AUGER SHAFT
BEA000533	TOP BEARING
FO11029	TORQUE ARM BASE
FO10299	TORQUE ARM (2 REQUIRED)
AO10397	TOP PLATE ASSEMBLY
AO10399	PACKING GLAND ASSEMBLY
MISC.	HYDRAULIC FITTINGS & HOSES
AO10390	COMPLETE AUGER ASSEMBLY

**LATCHES:**

FAS002498	BAGDOOR LATCH
FAS003124	REPLACEMENT U-BOLTS
FAS002668	5" CLEANOUTS ON DUCTWORK LATCH
FAS002671	CONTROL BOX DOOR LATCH
CLA020167	BIG DOOR LATCH
CLA020504	U-BOLT KIT FOR 344
FAS002560	PIN



**REAR CLEANOUT CHUTE DOORS:**

MISC.	OLD STYLE ROUND DOOR
AO11205	OVAL LEFT CHUTE DOOR
AO11206	OVAL RIGHT CHUTE DOOR
FAS003043	CHUTE DOOR ADJUSTING BOLTS
FAS002792	CHUTE DOOR SPRING

**TAILGATE LOCK MECHANISM PARTS:**

FO10504	OVER CENTERING CAM
FO10505	MOUNTING PLATE (2 REQUIRED)
FO10506	DOGBONE LINK (2 REQUIRED)
FO10507	SHORT LINK (2 REQUIRED)
FO10508	CYLINDER NEST PLATE (2 REQUIRED)
FO10509	OLD STYLE BIG PIN (4 REQUIRED)
FO10510	SMALL PIN
FO10511	ADJUSTING BOLT
WSO200-04.00	HYDRAULIC CYLINDER
FAS003248	JAM NUT
FAS020073	BIG SNAP RING
FIT020069	GREASE FITTING

**WASHDOWN SYSTEM:**

PUM009347 MODEL 320 WASHDOWN PUMP W/GUN ASSEMBLY &amp; HOSE

PUM009218 MODEL 420 WASHDOWN PUMP W/GUN ASSEMBLY &amp; HOSE

**REPLACEMENT PARTS:**

VAL012005 UNLOADER

FIT005200 INLET FITTING

ACC00095 FOOT MOUNT

HOS007016 HOSE

PUM009345 WATER PUMP

FAB002179 ADAPTER PLATE

MOT007821 HYDRAULIC MOTOR

VAL011577 THERMAL VALVE

GAU006579 GAUGE

**GUN PARTS:**

999150012 TRIGGER GUN ASSEMBLY

NOZ008083 NOZZLE

**WATER TANK:**

TNK022300 50 GALLON ALUMINUM TANK

**SERVICED YOUR VOLVO  
TRUCK LATELY?****WG SERIES:****WITH CUMMINS N14 ENGINE:**

3093313 OIL FILTER

3967982 FUEL &amp; WATER SEPARATOR

FG3927106S COOLANT FILTER

1117576 AIR FILTER

U3L3FE HYDRAULIC FILTER

**VHD SERIES:****WITH CUMMINS ISM ENGINE:**

3093312 OIL FILTER

3967982 FUEL &amp; WATER SEPARATOR

3945411 COOLANT FILTER

8076195 AIR FILTER

U3L3FE HYDRAULIC FILTER

Call for more info:

**888-442-7829**



GapVax<sup>®</sup>



575 Central Avenue  
Johnstown, PA 15902  
**888-442-7829**  
814-535-6766 814-535-2228/fax  
[www.gapvax.com](http://www.gapvax.com)